

DEC 04 1989

JOB NO. 126.03
STRN DODSON-89/004

**DRAINAGE CRITERIA MANUAL
FOR
MONTGOMERY COUNTY, TEXAS**

November 1989

presented to
Montgomery County

by

Dodson & Associates, Inc.

5629 FM 1960 West, Suite 314
Houston, Texas 77069
(713) 440-3787
FAX (713) 440-4742

D. A. Vogt Engineering, Inc.

1544 Sawdust Road, Suite 180
The Woodlands, Texas 77380
(713) 367-0947

TABLE OF CONTENTS

SECTION 1 INTRODUCTION 1

1.1 MONTGOMERY COUNTY DRAINAGE ADMINISTRATOR 1

1.2 DRAINAGE IMPROVEMENTS 1

1.3 ACKNOWLEDGEMENTS 2

SECTION 2 HYDROLOGIC ANALYSIS 3

2.1 INTRODUCTION 3

2.2 EFFECTS OF URBANIZATION 3

2.3 COMPUTATIONAL METHODS 3

2.4 HYDROLOGIC ANALYSIS OF WATERSHEDS SMALLER THAN 50 ACRES 4

 2.4.1 Rational Method 4

 2.4.1.1 Rational Method Runoff Coefficient (C) 5

 2.4.1.2 Rational Method Rainfall Intensity (i) 6

 2.4.1.3 Rational Method Drainage Area (A) 10

 2.4.1.4 Example of Rational Method Analysis 10

 2.4.2 Hydrograph Development for Small Watersheds 12

2.5 HYDROLOGIC ANALYSIS OF WATERSHEDS FROM 50 TO 640 ACRES 12

 2.5.1 Montgomery County Runoff Rate Curves 12

 2.5.1.1 Use of Runoff Rate Curves 15

 2.5.1.2 Example Application of Runoff Rate Curves 18

 2.5.2 Hydrograph Development 20

 2.5.2.1 Peak Flow Rates for Hydrograph Development 21

 2.5.2.2 Total Runoff Volume for Hydrograph Development 21

 2.5.2.3 Example of Hydrograph Development for Small Watersheds 24

2.6 HYDROLOGIC ANALYSIS OF WATERSHEDS LARGER THAN 640 ACRES 25

 2.6.1 Precipitation Data 25

 2.6.2 Precipitation Loss Computations 27

 2.6.3 Unit Hydrograph Procedure 28

 2.6.4 Adjustment for Ponding 30

 2.6.5 Streamflow Routing Procedure 31

 2.6.6 Example of HEC-1 Analysis 32

SECTION 3 OPEN CHANNELS 37

3.1 OPEN CHANNEL HYDRAULICS 37

 3.1.1 Critical Depth 37

 3.1.2 Sub-critical or Super-critical Flow 38

 3.1.3 The Manning Equation 38

 3.1.4 Manning "n" Values 38

3.2 OPEN CHANNEL DESIGN 42

 3.2.1 Design Frequencies for Open Channel Design 42

 3.2.2 Required Documentation for Open Channel Designs 42

 3.2.3 Channel Flow Velocities 43

 3.2.4 Channel Flow-Line Slope 43

 3.2.5 Channel Side Slope 43

 3.2.6 Channel Bottom Width 43

 3.2.7 Manning Roughness Coefficient 43

 3.2.8 Channel Transitions 44

 3.2.9 Channel Confluences 44

 3.2.10 Channel Bends 44

 3.2.11 Channel Maintenance 44

 3.2.12 Channel Erosion Control 44

 3.2.13 Minimum Requirements for Grass-Lined Channels 44

 3.2.14 Minimum Requirements for Concrete-Lined Trapezoidal Channels 45

 3.2.15 Minimum Requirements for Rectangular Concrete Pilot Channels 46

3.3 CHANNEL RIGHT-OF-WAY REQUIREMENTS 48

3.4 CHANNEL WATER SURFACE PROFILE COMPUTATIONS 48

 3.4.1 Orientation of Channel Cross-Sections 48

 3.4.2 Channel Stationing 49

 3.4.3 Channel Cross-Section Spacing 49

TABLE OF CONTENTS

3.4.4	Number of Data Points	49
3.4.5	Starting Water-Surface Elevation	49
3.4.6	Channel Friction Losses	49
3.4.7	Expansions and Contractions	50
3.4.8	Channel Bends	50
3.4.9	Bridges and Culverts	51
SECTION 4	CULVERTS AND BRIDGES	53
4.1	CULVERTS	53
4.1.1	Design Storm Frequency	53
4.1.2	Culvert Alignment	53
4.1.3	Culvert Length	53
4.1.4	Culvert Headwalls and Endwalls	53
4.1.5	Minimum Culvert Sizes	54
4.1.6	Manning's "n" Values for Culverts	54
4.1.7	Erosion at Culverts	54
4.1.8	Structural Requirements for Culverts	54
4.1.9	Hydraulic Design of Culvert Installations	56
4.1.9.1	Inlet-Controlled Flow	56
4.1.9.2	Outlet-Controlled Flow	56
4.1.9.3	Step by Step Culvert Design Procedure	59
4.1.9.4	Example of Culvert Design Procedure	62
4.2	BRIDGES	64
4.2.1	Design Storm Frequency	64
4.2.2	Bridge Alignment	64
4.2.3	Bridge Length	64
4.2.4	Piers and Abutments	65
4.2.5	Minimum Low Chord Elevation	65
4.2.6	Erosion Control	65
4.2.7	Hydraulic Design of Bridges	65
SECTION 5	SECONDARY DRAINAGE AND OVERLAND FLOW DESIGN	67
5.1	RUNOFF ANALYSES	67
5.1.1	Design Storm Frequencies	67
5.1.2	General Design Criteria	68
5.2	STORM SEWER DESIGN	73
5.2.1	Design Criteria for Storm Sewers	73
5.2.2	General Design Methods	74
5.2.3	Specific Design Flow Frequency Criteria	74
5.2.4	Starting Water Surface Elevation	75
5.2.5	Friction Losses in Storm Sewers	75
5.2.6	Minor Losses in Storm Sewers	75
5.2.7	Appurtenant Storm Sewer Structures	76
5.2.7.1	Storm Sewer Manholes	76
5.2.7.2	Storm Sewer Inlets	76
5.2.7.3	Storm Sewer Outfalls	77
5.3	OVERLAND FLOW DESIGN	77
5.3.1	Land Plan and Street Layout	77
5.3.2	Conveyance of Surface Flow to Primary Channels	80
5.3.3	Roadside Ditch Drainage	81
5.3.4	Extreme Event Storm Sewer Design	81
5.3.5	Off-Site Overland Flow	83
SECTION 6	EROSION AND SEDIMENT CONTROL	85
6.1	SOIL CONDITIONS	85
6.2	CHANNEL EROSION	85
6.2.1	Grass Establishment	85
6.2.2	Minimum Erosion Protection for Confluences	85
6.2.3	Minimum Erosion Protection Requirements for Bends	86
6.2.4	Minimum Erosion Protection for Culverts	88
6.2.5	Structural Measures for Erosion and Sediment Control	88
6.2.5.1	Rip-Rap	88

TABLE OF CONTENTS

6.2.5.2 Concrete Slope Paving	88
6.2.5.3 Straight Drop Spillway	88
6.2.5.3.1 Hydraulics of Straight-Drop Spillways	90
6.2.5.3.2 Design Procedure for Straight Drop Spillways	92
6.2.5.3.3 Example of Straight Drop Spillway Design	93
6.2.5.4 Sloped Drop Structures	96
6.2.5.5 Baffled Chutes	97
6.2.5.6 SAF-Type Stilling Basins	99
6.3 SECONDARY DRAINAGE SYSTEMS	103
6.3.1 Backslope Drainage Systems	103
6.3.2 Pipe Outfalls	105
6.3.3 Roadside Ditch Interceptor Structures	105
6.4 SEDIMENT CONTROL DURING CONSTRUCTION	107
SECTION 7 DETENTION DESIGN	109
7.1 TYPES OF STORAGE FACILITIES	109
7.1.1 Off-Line Facilities	109
7.1.2 On-Line Facilities	109
7.1.3 Retention Storage	111
7.1.4 Detention Storage	111
7.2 DESIGN CONSIDERATIONS	112
7.2.1 Location of Facility	112
7.2.2 Storm Sewer Hydraulic Gradients	112
7.2.3 Allowances for Extreme Storm Events	112
7.2.4 Multi-Purpose Use of Detention Facilities	112
7.2.5 Aesthetic Aspects of Detention Facility Design	112
7.2.6 Safety Considerations in Detention Facility Design	113
7.2.7 Erosion Control Measures for Detention Facilities	113
7.2.8 Maintenance of Detention Facilities	113
7.3 DETENTION DESIGN PROCEDURES	113
7.3.1 Detention Design Frequencies	113
7.3.2 Required Documentation for Detention Facility Designs	113
7.3.3 Detention Design For Drainage Areas of Less Than 50 Acres	114
7.3.4 Detention Design For Drainage Areas of 50 Acres to 640 Acres	115
7.3.5 Detention Design For Drainage Areas of 640 Acres or More	116
7.3.6 Design Tailwater Depth for Detention Facilities	116
7.3.7 Detention Outlet Structure Design	116
7.3.8 Outflow Pipes or Culvert	117
7.3.9 Horizontal Weir	117
7.3.10 V-notch Weir	119
7.3.11 Orifices	120
7.3.12 Pipe spillway with riser	123
7.3.13 Extreme Event Design	124
7.4 PUMP DETENTION FACILITIES	124
7.5 GEOTECHNICAL INVESTIGATION	124
7.6 GENERAL REQUIREMENTS FOR DETENTION POND CONSTRUCTION	124
SECTION 8 LEVEED AREAS	127
8.1 INTERNAL DRAINAGE SYSTEM	128
8.2 LEVEE SYSTEM	128
8.2.1 Frequency Criteria for Levee Systems	128
8.2.2 Design Criteria for Levee Systems	128
8.3 PUMP STATION DESIGN	129
8.3.1 Frequency Criteria for Pump Stations	129
8.3.1.1 Frequency Criteria for Coincident Events	129
8.3.1.2 Frequency Criteria for a Single Event	130
8.3.2 Design Criteria for Pump Stations	130
8.4 GRAVITY OUTLET AND OUTFALL CHANNEL	130
SECTION 9 FLOOD PLAIN DEVELOPMENT AND WATERSHED ANALYSIS	133
9.1 DEVELOPMENT IN THE 100-YEAR FLOOD PLAIN	133
9.1.1 Flood Plain Regulations	133

TABLE OF CONTENTS

9.1.2 Flood Plain Development Guidelines and Procedures 134
 9.2 DOWNSTREAM IMPACT ANALYSIS 134
 9.2.1 Acceptable Alternative Courses of Action 135
 9.2.2 Flood Routing Studies 135
SECTION 10 BIBLIOGRAPHY 137

Table of Figures

2.1 Rainfall Intensity-Duration-Frequency Curves 7
 2.2 Watershed for Rational Method Example 11
 2.3 Montgomery County Runoff Rate Curves for 25-Year Storm 13
 2.4 Montgomery County Runoff Rate Curves for 100-Year Storm 14
 2.5 Blank Worksheet for Flow Rate Computation 17
 2.6 Example Watershed for Curve Flow Rates 18
 2.7 Example Worksheet for Flow Rate Computation 19
 2.8 Malcom Method Hydrograph 21
 2.9 Determination of Runoff Volume Using SCS Curve Number 22
 2.10 Typical HEC-1 Storm Distribution 26
 2.11 HEC-1 Exponential Loss Rate Function 27
 2.12 HEC-1 Clark Unit Hydrograph 29
 2.13 Example Watershed Map 32
 2.14 Average Upstream Channel Cross-Sections 33
 2.15 Average Downstream Channel Cross-Section 33
 2.16 Example Watershed HEC-1 Output 34
 3.1 Typical Section - Grass-Lined Trapezoidal Channel 45
 3.2 Typical Section - Concrete-Lined Trapezoidal Channel 45
 3.3 Typical Section - Concrete-Lined Low Flow Channel 47
 3.4 Concrete-Lined Low Flow Channel with Maintenance Shelf 47
 4.1 Profile of Typical Culvert 55
 4.2 Section of Typical Culvert 55
 4.3 Typical Culvert Outlet 55
 4.4 Hydraulic Elements of Pressure Flow Through Culverts 58
 4.5 Culvert Design Form 60
 4.6 Example Culvert Design Form 63
 5.1 Effect of Low Starting Elevation on Storm Sewers 67
 5.2 Effect of Medium Starting Elevation on Storm Sewers 68
 5.3 Effect of High Starting Elevation on Storm Sewers 68
 5.4 Rainfall-Runoff Curves for Storm Sewer Design 69
 5.5 Typical Storm Sewer Outfall (24-inch to 42-inch) 71
 5.6 Typical Storm Sewer Outfall (42-inch and larger) 72
 5.7 Undesirable Overland Flow Pattern at Cul-de-sac Street 78
 5.8 Acceptable Overland Flow Pattern at Cul-de-sac Street 78
 5.9 Undesirable Overland Flow Pattern at Roadway Curve 79
 5.10 Acceptable Overland Flow Pattern at Roadway Curve 79
 5.11 Undesirable Overland Flow at Street Intersections 80
 5.12 Acceptable Overland Flow at Street Intersections 80
 6.1 Typical Channel Confluence 86
 6.2 Typical Channel Bend 87
 6.3 Cross-Section of Typical Straight Drop Spillway 89
 6.4 Plan View of Typical Straight Drop Spillway 89
 6.5 Profile View of Typical Straight Drop Spillway 89
 6.6 Flow Geometry of Straight Drop Spillway 90
 6.7 Length of Hydraulic Jumps 91
 6.8 Typical Baffled Chute 97
 6.9 Recommended Baffle Pier Heights and Allowable Velocities 98
 6.10 Plan View of Rectangular SAF-Type Stilling Basin 100
 6.11 Section of Rectangular SAF-Type Stilling Basin 101
 6.12 Elevation of Rectangular SAF-Type Stilling Basin 101
 6.13 Plan View of Trapezoidal SAF-Type Stilling Basin 102
 6.14 Section of Trapezoidal SAF-Type Stilling Basin 102

TABLE OF CONTENTS

6.15 Elevation of Trapezoidal SAF-Type Stilling Basin	103
6.16 Typical Backslope Interceptor Structure	104
6.17 Typical Roadside Ditch Interceptor Structure	106
7.1 Cross-Section of Typical Detention Basin	110
7.2 Typical Detention Basin Configuration	110
7.3 Effect of Retention Storage on Hydrographs	111
7.4 Effect of Detention Storage on Hydrographs	111
7.5 Required Detention Volume for Less Than 50 Acres	114
7.6 Typical Pipe or Box Culvert Outlet Structure	117
7.7 Sharp-Crested Rectangular Weir	117
7.8 Section Through Sharp-Crested Weir	118
7.9 Capacity Adjustments for Submerged Weirs	119
7.10 Sharp-Crested V-Notch Weir	120
7.11 Circular Orifice	121
7.12 Rectangular Orifice	121
7.13 Unsubmerged Orifice	122
7.14 Submerged Orifice	123
7.15 Pipe Outlet Structure with Drop Structure Inlet	123
8.1 Typical Layout of Levee Entirely Within Flood Plain	127
8.2 Typical Layout of Levee Tied into High Ground	127
8.3 Typical Levee Cross-Section	128
9.1 100-Year Flood Plain and Floodway	133

Table of Tables

2.1 Rational Method Frequency Factor Adjustment	5
2.2 Rational Method Runoff Coefficients for 5-10 Year Storms	6
2.3 Manning's Roughness Coefficients for Overland Flow	9
2.4 Point Rainfall Depths	10
2.5 Sub-Areas of Example Watershed	11
2.6 Pipe Segments in Example Watershed	11
2.7 Example Rational Method Calculations	12
2.8 Equations Used in Plotting Runoff Rate Curves	15
2.9 Parameters Used with Runoff Rate Curves	15
2.10 Values of SCS Curve Number for Rural Areas	23
2.11 Values of SCS Curve Number for Urban and Suburban Areas	24
2.12 Computed Runoff Hydrograph for Example Watershed	25
2.13 Recommended Values for HEC-1 Loss Parameters	28
2.14 Typical Average Values for Impervious Cover	28
2.15 Coefficients for Computing Ponding Adjustment Factor	31
2.16 Parameters for Example Watershed	32
3.1 Manning Coefficient for Lined or Built-Up Channels	39
3.2 Manning Roughness Coefficient for Excavated Channels	40
3.3 Manning Roughness Coefficient for Minor Natural Streams	40
3.4 Manning Roughness Coefficient for Major Natural Streams	40
3.5 Manning Roughness Coefficient for Flood Plains	41
3.6 Parameters Used in Computing Roughness Coefficient	41
3.7 Allowable 25-Year Flow Velocities for Channel Design	43
3.8 Manning Roughness Coefficient for Improved Channel	43
3.9 Minimum Thickness and Reinforcement for Slope Paving	46
3.10 Channel Right-of-Way Requirements	48
3.11 Typical Transition Loss Coefficients	50
4.1 Manning Roughness Coefficient for Corrugated Metal Pipe	54
4.2 Entrance Loss Coefficients for Concrete Pipe Culverts	57
4.3 Entrance Loss Coefficients for Corrugated Metal Culverts	57
4.4 Entrance Loss Coefficients for Concrete Box Culverts	57
5.1 Curve Numbers for Rainfall-Runoff Curves	70
5.2 Values of Manning Roughness Coefficient for CMP	73
5.3 Coefficients for Entrance Losses	76
5.4 Coefficients for Losses at Structures	76
6.1 Minimum Erosion Protection for Channel Confluences	86
6.2 Minimum Extent of Erosion Protection for Confluences	86

TABLE OF CONTENTS

6.3 Minimum Erosion Protection for Channel Bends	87
6.4 Allowable 25-Year Flow Velocities for Channel Design	87
6.5 Example of Computed Hydraulic Values	94
6.6 Example of Computed Opening Widths	95
6.7 Example of Simplified Opening Widths	95
6.8 Example HEC-2 Results for Upstream Channel	95
6.9 Example of Computed Drop Lengths	96

SECTION 1 INTRODUCTION

This drainage criteria manual establishes standard principles and practices for the design and construction of drainage systems in Montgomery County, Texas. The design factors, formulas, graphs, procedures, tables, and figures presented in the manual are intended to establish guidelines for the solution of drainage problems involving determinations of the quantity of runoff, rate of flow, method of collection, storage, and conveyance of storm water.

Methods of design other than those indicated herein may be considered in some cases where experience clearly indicates that they are preferable. However, there should be no extensive variations from the practices established within this manual without the express approval of the Montgomery County Drainage Administrator.

1.1 MONTGOMERY COUNTY DRAINAGE ADMINISTRATOR

In this manual, the supervisory role for drainage planning and administration within the County is assumed to reside in a hypothetical office called the *Montgomery County Drainage Administrator*. Many of the responsibilities of this office can be fulfilled by the County Engineer. However, should a separate drainage district or other similar entity be created, the new agency may assume the role of Montgomery County Drainage Administrator in administering this criteria manual.

1.2 DRAINAGE IMPROVEMENTS

The Montgomery County Drainage Administrator shall be responsible for the review and approval of all plans for *100-year design drainage facilities* within Montgomery County. **Generally, 100-year design drainage facilities are those serving a drainage area of one square mile (640 acres) under existing or proposed conditions, or which serve drainage areas containing more than one political subdivision (city, Municipal Utility District, etc.).**

The County has included in this manual criteria covering the design of storm water systems to serve both existing and new developments. All new drainage facilities must take into consideration the existing drainage patterns and facilities in upstream areas. In addition, new development must provide sufficient right-of-way width to Montgomery County to accommodate the drainage needs of future development in upstream areas.

The County is responsible for the approval and, upon acceptance, the maintenance, operation, and necessary expansion of 100-year design drainage facilities (existing or proposed) which are in drainage rights-of-way dedicated to Montgomery County. Upon the completion of all new 100-year design drainage facilities, the County will accept, maintain, and operate said facilities for flood control purposes as an extension of the County's existing drainage system if the facilities are constructed in accordance with plans approved by the County. Until the County accepts new 100-year design drainage facilities, the previous owner shall continue to properly operate and maintain those facilities to perform according to the original design specifications for the facilities. Those drainage facilities, including detention facilities, which are planned and accepted for maintenance by some other perpetual special purpose district (such as a Levee Improvement District) will not be accepted by the County.

The criteria in this manual are considered a minimum for Montgomery County approval. Approval from other applicable agencies may be required. Ultimate approval for any variance of the criteria contained in this manual must be given by the Montgomery County Drainage Administrator.

1.3 ACKNOWLEDGEMENTS

This manual has been prepared by Dodson & Associates, Inc. of Houston, Texas, in cooperation with D. A. Vogt Engineering, Inc. of The Woodlands, Texas. The preparation of the manual fulfills a portion of these firms' obligations under a contract with Montgomery County pursuant to an agreement between the County and the Texas Water Development Board.

The substantial assistance provided by Montgomery County Engineer Don Blanton and his staff during the preparation and completion of this manual is gratefully acknowledged. Montgomery County Precinct Three Commissioner Ed Chance and Montgomery County Judge Al Stahl have also been extremely supportive and helpful. The assistance of Texas Water Development Board representative Robert R. Wear is greatly appreciated.

Dodson & Associates, Inc. has gathered over 70 drainage criteria manuals from throughout the United States. Those manuals were available for use in preparing this manual. However, the content of this manual is largely derived from the *Fort Bend County Drainage Criteria Manual* [EHA, 1987] and the *Criteria Manual for the Design of Flood Control and Drainage Facilities in Harris County, Texas*, [HCFCD, 1984]. These manuals are particularly important because of their quality and completeness, and because they represent accepted criteria applied in the area around Montgomery County.

SECTION 2 HYDROLOGIC ANALYSIS

The purpose of this section is to establish standard procedures and criteria for the performance of hydrologic analyses within Montgomery County.

2.1 INTRODUCTION

The planning, design, and construction of drainage facilities are based on the determination of one or more aspects of storm runoff. If the estimate of storm runoff is incorrect, the constructed facilities may be undersized, oversized, or otherwise inadequate. An improperly designed drainage system can be uneconomical, cause flooding, interfere with traffic, disrupt commercial and other activities, and be a general nuisance in the affected area. However, the peak flow rate, volume and time-sequence of storm runoff related to a certain recurrence interval (frequency) can only be approximated because of the many physical and climatic factors involved.

Continuous long-term records of rainfall and resulting storm runoff in an area provide the best data source on which to base the design of storm drainage and flood control systems in that area. However, it is not possible to obtain such records in sufficient quantities for all locations requiring storm runoff computations. Therefore, the accepted practice is to relate storm runoff to rainfall, thereby providing a means of estimating the rates, timing, and volume of runoff expected within local watersheds at various recurrence intervals. Although numerous methods to relate rainfall and runoff have been considered, three methods are recommended for use in Montgomery County. These methods, discussed in subsequent sections, provide reasonable and consistent procedures for approximating the characteristics of the rainfall-runoff process.

2.2 EFFECTS OF URBANIZATION

It is generally accepted that urban development has a pronounced effect on the rate and volume of runoff from a given rainfall. Urbanization generally alters the hydrology of a watershed by improving hydraulic efficiency, reducing surface infiltration and reducing storage capacity. The reduction of a watershed's storage capacity and surface infiltration is a result of the elimination of porous surfaces and ponding areas by grading and paving building sites, streets, drives, parking lots, and sidewalks and by constructing buildings and other facilities characteristic of urban development.

Zoning maps, future land use maps, and watershed master plans should be used as aids in establishing the anticipated surface character following development. The selection of design runoff coefficients and impervious cover factors, which are explained in the following discussions of runoff calculation, must be based upon the appropriate degree of urbanization.

2.3 COMPUTATIONAL METHODS

Because of its versatility and accuracy, the widely used HEC-1 computer program, which was developed by the U.S. Army Corps of Engineers Hydrologic Engineering Center (HEC) in Davis, California, is recommended as the primary tool for modeling storm runoff in Montgomery County. Accordingly, the hydrologic design techniques described in this manual incorporate many of the routines contained in HEC-1. The principal routines used for computing runoff in the County as presented in this section are based on the Clark unit hydrograph technique, design rainfall events, and empirical rainfall loss functions.

A methodology for deriving the parameters used to compute the Clark unit hydrograph was developed for Fort Bend County, Texas by Espey, Huston & Associates, Inc. [EHA, 1987]. This methodology was developed from optimization studies utilizing U.S. Geological Survey regional rainfall-runoff data and standard unit hydrograph techniques. The Fort Bend County methodology

is appropriate for a wide range of watershed sizes and is the recommended method for Montgomery County in all but certain small areas in which only peak discharge determinations are required. The application of the methodology is described later in this manual.

For areas less than 640 acres (one square mile) and greater than 50 acres, drainage area-discharge curves have been developed as a means to determine peak discharge. For drainage areas of less than 50 acres, the Rational Method may be used to determine peak discharges.

2.4 HYDROLOGIC ANALYSIS OF WATERSHEDS SMALLER THAN 50 ACRES

For small drainage areas (less than 50 acres in size), the widely used Rational Method provides a useful means of determining peak discharges. In situations requiring determination of a complete flood hydrograph, and not just a peak discharge, a method developed by H.R. Malcom [Malcom, Undated] should be utilized. The Malcom method is described later in this manual. Engineers wishing to use an alternative design technique should consult the Montgomery County Drainage Administrator prior to design.

2.4.1 Rational Method

The Rational Method represents an accepted method for determining peak storm runoff rates for small watersheds that have a drainage system unaffected by complex hydrologic situations such as ponding areas, storage basins and watershed transfers (overflows) of storm runoff. This widely used method provides satisfactory results if understood and applied correctly. It is generally recommended that in Montgomery County the Rational Method be used only for areas of less than 50 acres.

The Rational Method is based on a direct relationship between rainfall intensity and runoff, and is expressed by the following equation:

$$Q = CiA \qquad \text{Equation 2.1}$$

in which:

Q = the peak rate of runoff in cubic feet per second (cfs). Actually, Q is in units of inches per hour per acre. Since this rate of in-ac/hr differs from cubic feet per second by less than one percent, the more convenient units of cfs are used

C = the dimensionless coefficient of runoff representing the ratio of peak discharge per acre to rainfall intensity (i)

i = the average intensity of rainfall in inches per hour for a period of time equal to the time of concentration for the drainage area at the point of interest

A = the area in acres contributing runoff to the point of interest during the critical storm duration.

Basic assumptions associated with the Rational Method are:

- 1) The computed peak rate of runoff at the point of interest is a function of the average rainfall intensity during a period of time equal to the time of concentration at that point.
- 2) The frequency or recurrence interval of the peak discharge is equal to the frequency of the average (uniform) rainfall intensity associated with the critical storm duration.
- 3) The time of concentration is the critical storm duration. This is discussed under SECTION 2.4.1.2.
- 4) The ratio of runoff rate to rainfall intensity, C , is uniform during the storm duration.
- 5) Rainfall intensity is uniform during the storm duration.
- 6) The contributing area is the area that drains to the point of interest within the critical time of concentration.

2.4.1.1 Rational Method Runoff Coefficient (C)

In relating peak rainfall rates to peak discharges, the runoff coefficient "C" in the Rational Formula is dependent on the character of the surface of the drainage area. The rate and volume of runoff that reaches a storm drainage system depends on the relative porosity (**imperviousness**), ponding character, slope, and conveyance properties of the surface. Soil type, vegetative condition, and the presence of impervious surfaces, such as asphalt pavements and the roofs of buildings, are the major determining factors in selecting an area's "C" factor. The type and condition of the surface determines its ability to absorb precipitation and transport runoff.

The rate at which a soil absorbs precipitation generally decreases as rainfall continues for an extended period of time. The soil absorption or infiltration rate is also influenced by the presence of soil moisture before a rain (**antecedent precipitation**), the rainfall intensity, the depth of the ground water table, the degree of soil compaction, the porosity of the subsoil, vegetation, ground slopes, depressions, and storage. On-site inspections and aerial photographs may prove valuable in evaluating the nature of the surface within the drainage area.

The runoff coefficient "C" is difficult to precisely determine. Its use in the Rational Method implies a fixed ratio of runoff rate to rainfall intensity for any given drainage area, which in reality is not the case. A reasonable coefficient must be chosen to represent the integrated effects of infiltration, detention storage, evaporation, retention, flow routing, and interception, all of which affect the time distribution and peak rate of runoff. Proper use of the Rational Method requires judgement and experience on the part of the engineer, especially in the selection of the runoff coefficient.

Coefficients for specific surface types can be used to develop a composite runoff coefficient based in part on the percentage of different types of surfaces in the drainage area. This procedure is often applied to typical "sample" blocks as a guide to the selection of reasonable values of the coefficient for an entire area.

Table 2.2 presents recommended values for the runoff coefficient "C" for various residential districts and specific surface types for 5 to 10 year frequency storms. Adjustment of the "C" value for use with more severe (less frequent) storms can be made by multiplying the runoff coefficient by a **frequency factor** C_f , which is used to account for antecedent precipitation conditions. The Rational Formula now becomes:

$$Q = C_f \times C_i A \quad \text{Equation 2.2}$$

Table 2.1 presents recommended values of C_f . **The product of C times C_f should not exceed 1.0.**

TABLE 2.1 Rational Method Frequency Factor Adjustment

Frequency of Storm (years)	Frequency Factor (C_f)
≤ 10	1.00
25	1.10
50	1.20
100	1.25

Source: "Urban Storm Drainage Criteria Manual," 1969.

TABLE 2.2 Rational Method Runoff Coefficients for 5-10 Year Frequency Storms

Description of Area	Basin Slope < 1%	Basin Slope 1%-3.5%	Basin Slope 3.5%-5.5%
Single Family Residential Districts			
Lots greater than 1/2 acre	0.30	0.35	0.40
Lots 1/4 - 1/2 acre	0.40	0.45	0.50
Lots less than 1/4 acre	0.50	0.55	0.60
Multi-Family Residential Districts	0.60	0.65	0.70
Apartment Dwelling Areas	0.75	0.80	0.85
Business Districts			
Downtown	0.85	0.87	0.90
Neighborhood	0.75	0.80	0.85
Industrial Districts			
Light	0.50	0.65	0.80
Heavy	0.60	0.75	0.90
Railroad Yard Areas	0.20	0.30	0.40
Cemeteries	0.10	0.18	0.25
Playgrounds	0.20	0.28	0.35
Streets			
Asphalt	0.80	0.80	0.80
Concrete	0.85	0.85	0.85
Concrete Drives and Walks	0.85	0.85	0.85
Roofs	0.85	0.85	0.85
Lawn Areas			
Sandy Soil	0.05	0.08	0.12
Clay Soil	0.15	0.18	0.22
Woodlands			
Sandy Soil	0.15	0.18	0.25
Clay Soil	0.18	0.20	0.30
Pasture			
Sandy Soil	0.25	0.35	0.40
Clay Soil	0.30	0.40	0.50
Cultivated			
Sandy Soil	0.30	0.55	0.70
Clay Soil	0.35	0.60	0.80

2.4.1.2 Rational Method Rainfall Intensity (i)

Rainfall intensity (*i*) is the average rainfall rate in inches per hour which is considered for a particular basin or sub-basin. The rainfall intensity is determined on the basis of design rainfall duration and design frequency of occurrence. The **design rainfall duration** is equal to the critical time of concentration for all portions of the drainage area under consideration that contribute flow to the point of interest. The **frequency of occurrence** used in design computations is a statistical variable which is established by design standards or chosen by the engineer as a design parameter. It is usually expressed in terms of the average storm recurrence interval in years.

The **time of concentration** used in the rational equation is the time of concentration for the entire drainage area upstream of the point of interest. The **critical time of concentration** is the time of concentration which results in the maximum peak runoff rate from all or part of the upstream drainage area at the point of interest. This may be equal to or less than the time of concentration. Runoff from a watershed usually reaches a peak at the time when the entire

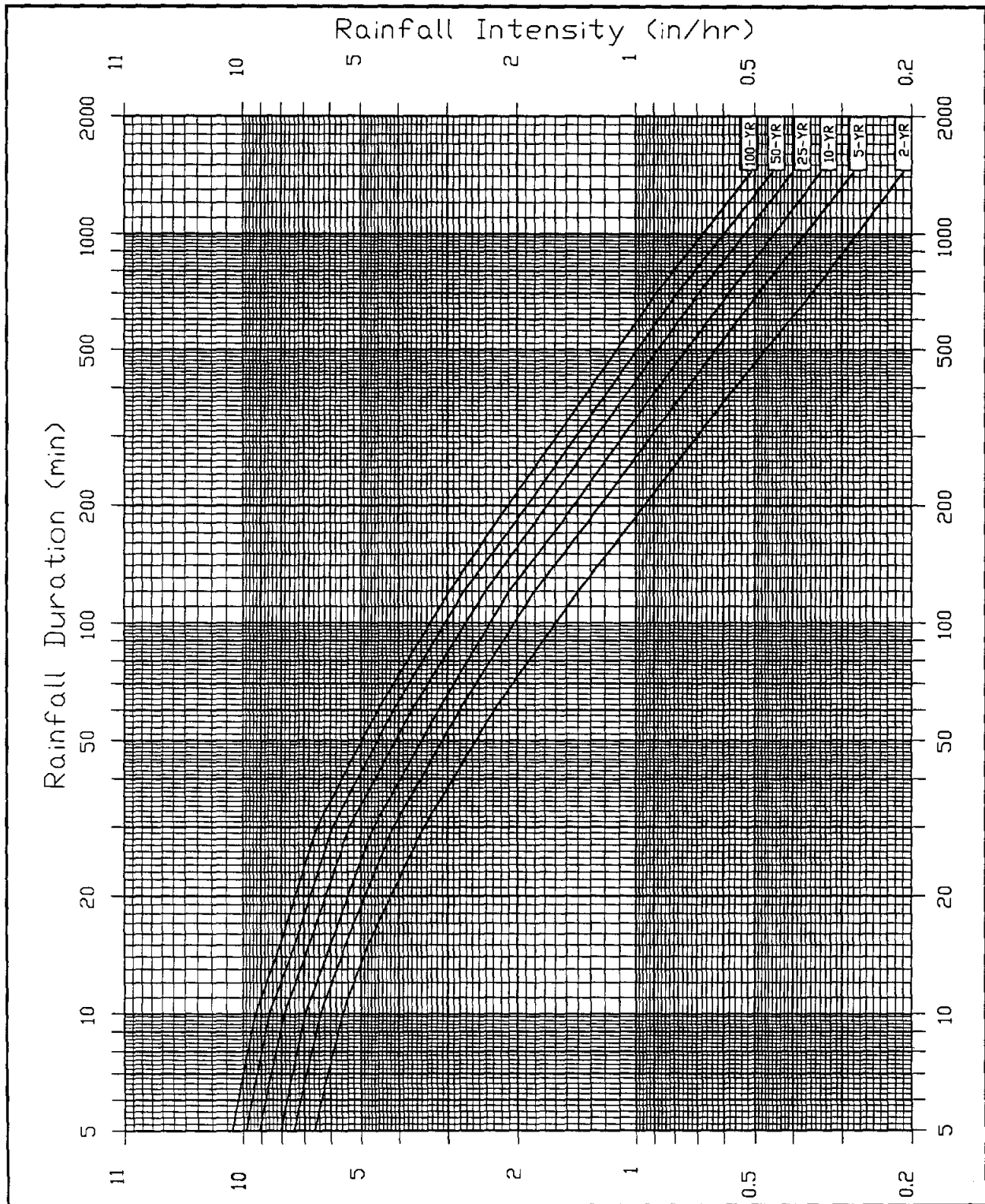

FIGURE 2.1 Rainfall Intensity-Duration-Frequency Curves for Montgomery County

drainage area is contributing. However, the runoff rate may reach a peak prior to the time when the entire upstream drainage area is contributing. In such instances, only the portions of the drainage area able to contribute flow at the point of interest during the critical time of concentration should be used in determining the peak discharge.

A trial and error procedure can be used to determine the critical time of concentration. The following steps are involved:

- 1) Compute the time of concentration for the entire upstream drainage area as the time required for water to flow from the most remote point in the watershed to the point of interest.
- 2) Use the computed time of concentration along with other Rational Method parameters to compute a peak flow rate at the point of interest.
- 3) Inspect the drainage area map and the computations for the time of concentration to determine if any of the upstream or outer portions of the drainage area are contributing more to the computed time of concentration than to the drainage area of the watershed. For example, a poorly-drained area at the upstream end of the watershed may be contributing 20% of the time of concentration, but may constitute only 5% of the total watershed area.
- 4) Re-compute the time of concentration and resulting peak flow rate for the watershed without the area(s) identified in step 3).
- 5) Repeat steps 1) through 4) until the highest peak flow rate results.

The time of concentration at any point in a storm drainage system is a combination of the inlet time and the travel time in the conduit or channel.

The **inlet time** is the time for water to flow over the watershed surface to the storm sewer inlet or channel. Inlet time decreases as the slope and the hydraulic efficiency of the surface increase. It increases as the distance over which the water has to travel increases and as retention by the contact surfaces increases. Average velocities for estimating travel time for overland flow can be calculated using methods outlined in SCS TR-55 [SCS, 1986].

Overton & Meadows (1976) developed the following equation for time of travel for overland sheet flow over distances of 300 feet or less:

$$T_t = \frac{0.007(n \times L)^{0.8}}{\sqrt{P_2} \times S^{0.4}} \quad \text{Equation 2.3}$$

in which:

T_t = travel time (hours)

n = Manning's roughness coefficient

L = overland flow distance (feet)

P_2 = 2-year, 24-hour rainfall depth (inches)

S = land slope (feet per foot)

This equation is based on the following assumptions:

- 1) Shallow, steady uniform flow
- 2) Constant intensity of rainfall excess
- 3) Rainfall duration equal to 24 hours
- 4) Infiltration has a minor effect on travel time.

Table 2.3 presents representative values of Manning's roughness coefficient for a variety of flow surfaces.

Table 2.3 Manning's Roughness Coefficients for Overland Sheet Flow

Surface	n
Smooth Surfaces (concrete, asphalt, gravel, bare soil)	0.011
Fallow (no residue)	0.05
Cultivated Soils: Residue Cover \leq 20%	0.06
Cultivated Soils: Residue Cover $>$ 20%	0.17
Grass: Short Grass Prairie	0.15
Grass: Dense Grasses	0.24
Grass: Bermuda Grass	0.41
Range (natural)	0.13
Woods: Light Underbrush	0.40
Woods: Dense Underbrush	0.80

Source: SCS TR-55 [SCS, 1986]

The following flow velocity equations are presented in SCS TR-55 for shallow concentrated flow:

$$V = 16.1345\sqrt{S} \quad \text{(unpaved areas)} \quad \text{Equation 2.4}$$

$$V = 20.3282\sqrt{S} \quad \text{(paved areas)} \quad \text{Equation 2.5}$$

in which:

V = flow velocity (feet per second)

S = overland slope (feet per foot)

Using flow velocities computed from these equations, overland travel times may be computed using the following equation:

$$T = \frac{D_F}{60V} \quad \text{Equation 2.6}$$

in which:

T = overland flow time (minutes)

D_F = flow distance (feet)

V = average velocity of runoff flow (ft/sec)

The total overland travel time may be computed as the sum of the travel times for overland sheet flow and shallow concentrated flow. If the overland flow time is calculated to be in excess of 20 minutes, the designer should verify that the time is reasonable.

The **travel time** in the conduit or channel is the quotient of the length of the conduit or channel and the velocity of flow as computed using the hydraulic characteristics of the conduit or channel. The travel time is usually less than the actual time for the flood crest to reach a given point by an amount equal to the time required to fill the conduit or channel, which is called the **time of storage**. The time of storage is usually small compared with the travel time. In order to help assure a conservative design, the time of storage shall be neglected in the design of storm runoff conduits.

The statistical relationship between the rainfall intensity and duration for the 2-year, 5-year, 10-year, 25-year, 50-year, and 100-year frequency storms are shown in Figure 2.1. These curves are presented for durations from 5 minutes to 24 hours. Table 2.4 presents rainfall depths for a variety of durations and frequencies. The rainfall intensities plotted in Figure 2.1 are computed by dividing the point rainfall amounts listed in Table 2.4 by the corresponding duration of rainfall.

TABLE 2.4 Point Rainfall Depths for Varying Durations and Frequencies

Duration	Rainfall Frequency					
	2-year	5-year	10-year	25-year	50-year	100-year
5-minute [†]	0.56	0.63	0.68	0.76	0.83	0.89
10-minute [†]	0.93	1.06	1.16	1.31	1.43	1.55
15-minute [†]	1.19	1.36	1.49	1.69	1.84	2.00
30-minute [†]	1.71	2.05	2.30	2.66	2.95	3.23
60-minute [†]	2.26	2.77	3.14	3.66	4.09	4.48
2-hour [†]	2.74	3.58	4.13	4.77	5.38	5.88
3-hour [†]	3.04	3.92	4.61	5.35	6.00	6.70
6-hour [†]	3.58	4.71	5.56	6.58	7.35	8.32
12-hour [†]	4.12	5.67	6.72	8.19	9.15	10.31
24-hour [†]	4.84	6.59	8.09	9.43	10.55	12.17

Sources: [†][Frederick, 1977]; [‡][Hershfield, 1961]

2.4.1.3 Rational Method Drainage Area (A)

As mentioned previously, the drainage area used in determining peak discharges is the portion of the area that contributes flow to the point of interest within the critical time of concentration. The boundaries of the drainage area may be determined through the use of topographic maps, supplemented by field surveys where topographic data has changed or where the contour interval is too great to distinguish the direction of flow. A drainage area map shall be provided for each project. The drainage area contributing to the system being designed and the drainage sub area contributing to each inlet point shall be identified. The boundaries of each drainage area must follow actual drainage divides rather than artificial land divisions as used in the design of sanitary sewers. The drainage divide lines are determined by pavement slopes, downspout locations, grading of lawns, and many other features that are introduced by the urbanization process.

2.4.1.4 Example of Rational Method Analysis

A storm drainage system includes the four areas shown in Figure 2.2. Table 2.5 lists the drainage area, runoff coefficient, flow distance to the inlet, and average overland flow velocity for each sub-area. Table 2.6 lists the data for each pipe segment in the storm drainage system, including the computed full flow velocity and travel time for each pipe.

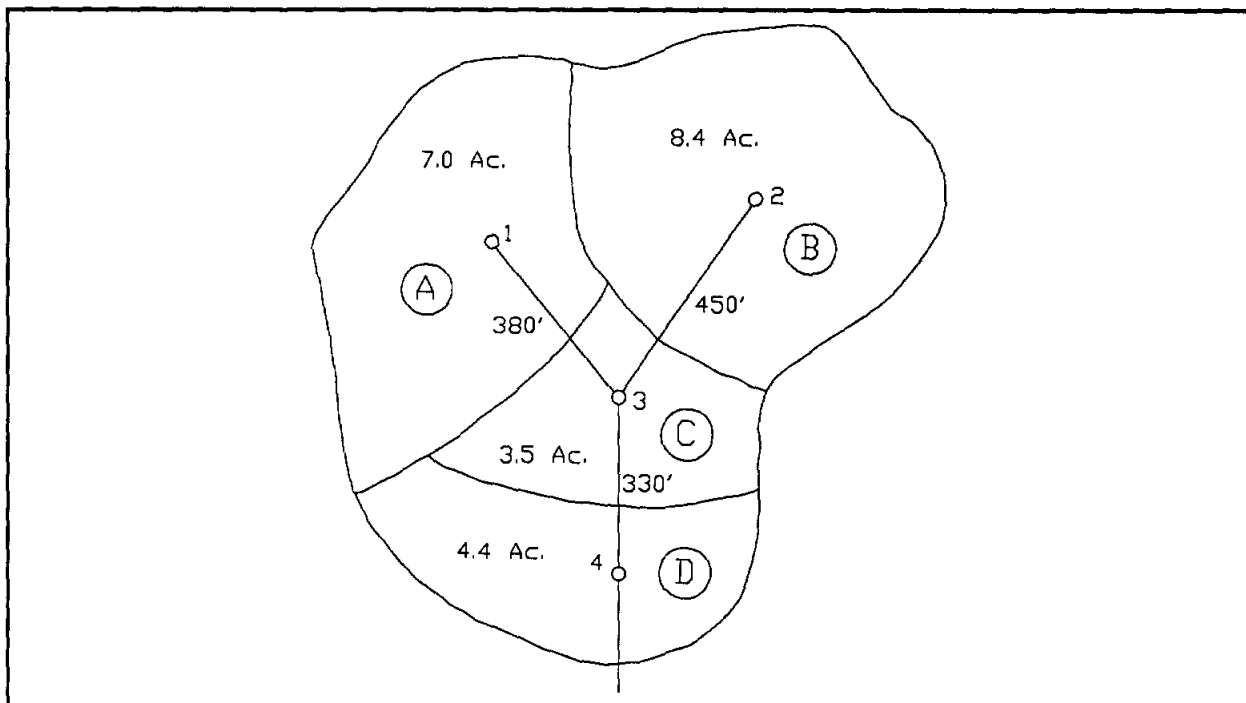

FIGURE 2.2 Watershed for Rational Method Example

TABLE 2.5 Sub-Areas of Example Watershed

Sub-Area	Area (ac)	Runoff Coefficient	Flow Distance (ft)	¹ Flow Velocity (fps)	¹ Inlet Time (min)
A	7.0	0.5	550	0.5	18
B	8.4	0.5	600	0.5	20
C	3.5	0.6	420	0.7	10
D	4.4	0.8	600	2.0	5

¹Computed Using Equation 2.6¹Computed Using Equations 2.3 - 2.5.

TABLE 2.6 Pipe Segments in Example Watershed

Pipe Segment	Length (ft)	Diameter (in)	Slope (ft/ft)	¹ Full Flow Velocity (fps)	Travel Time (min)
1-3	380	30	0.003	5.0	1.3
2-3	450	30	0.003	5.0	1.5
3-4	330	42	0.002	5.0	1.1

¹Computed Using Manning's Equation

Table 2.7 lists the results of the flow computations for the 5-year storm event. The sequence of computations is as follows:

- 1) Compute the product of the drainage area and runoff coefficient for each sub-area, $a \times C$. Since this is a 5-year storm event, the frequency factor C_f equals 1.0.
- 2) Compute the total $a \times C$ value at each analysis point, considering all drainage areas contributing to flow at that location.

- 3) Compute the total time of concentration at each analysis point, considering inlet time as well as travel time. For points where two or more storm sewer branches come together, such as Point No. 3, the total time of concentration should be computed for each possible flow path. The longest time of concentration is used for flow computations. **Never add peak flow rates at junctions.**
- 4) Determine the 5-year rainfall intensity from the Intensity-Duration-Frequency curves illustrated in Figure 2.1 for each time of concentration.
- 5) Compute the peak flow rate with Equation 2.1, using the total $a \times C$ value and the computed rainfall intensity for each analysis point.

TABLE 2.7 Example Rational Method Calculations

Manhole	Area, a (acres)	Coefficient C	$a \times C$	$\Sigma(a \times C)$	Routes	Inlet Time (min)	Travel Time (min)	Total Time (min)	Intensity (in/hr)	Q (cfs)
1	7.0	0.5	3.5	3.5	A	18.0	0.0	18.0	5.1	17.9
2	8.4	0.5	4.2	4.2	B	20.0	0.0	20.0	4.9	20.6
3	3.5	0.6	2.1	9.8	A, 1-3	18.0	1.3	19.3		
	3.5	0.6	2.1	9.8	B, 2-3	20.0	1.5	21.5	4.7	46.1
4	4.4	0.8	3.5	13.3	B, 2-4	20.0	2.6	22.6	4.6	61.2

2.4.2 Hydrograph Development for Small Watersheds

Whenever the situation requires the determination of a complete flood hydrograph, and not just a peak discharge, Malcom's method, as described in SECTION 2.5.2, should be used.

2.5 HYDROLOGIC ANALYSIS OF WATERSHEDS FROM 50 TO 640 ACRES

Hydrologic analyses involving watersheds of greater than or equal to 50 acres and less than 640 acres may be completed using one of two approaches. The first is the use of runoff rate curves for Montgomery County to determine peak flow rates and the Malcom Method to develop runoff hydrographs. These methods are described in SECTION 2.5.1 and SECTION 2.5.2.

The second approach is the use of the HEC-1 computer program to compute complete runoff hydrographs. The use of the HEC-1 program is described in SECTION 2.6. The HEC-1 method will be required whenever it is necessary to perform detailed analyses of watersheds with multiple sub-areas.

2.5.1 Montgomery County Runoff Rate Curves

The Montgomery County Runoff Rate curves represent a simplified method for the determination of the peak discharge in a relatively small watershed. The use of this type of analysis requires that the watershed and its physical characteristics be relatively uniform and not contain complex hydrologic features such as ponding areas, storage basins, or watershed overflows. HEC-1 should be used instead of the Runoff Rate curves if channel routing or hydrograph combination steps are required.

The curves developed for this manual for the 25-year and 100-year rainfall events, respectively, are shown in Figures 2.3 and 2.4. The curves are applicable to drainage areas between 50 and 640 acres in Montgomery County. The curves may also be useful in providing preliminary estimates of flow rates for larger areas. Since there is such a great variation in the physical characteristics of partially developed watersheds along with a wide range of conveyance capacity (i.e. flood plain storage), these curves are developed to consider some of the most important physical characteristics of the watershed.

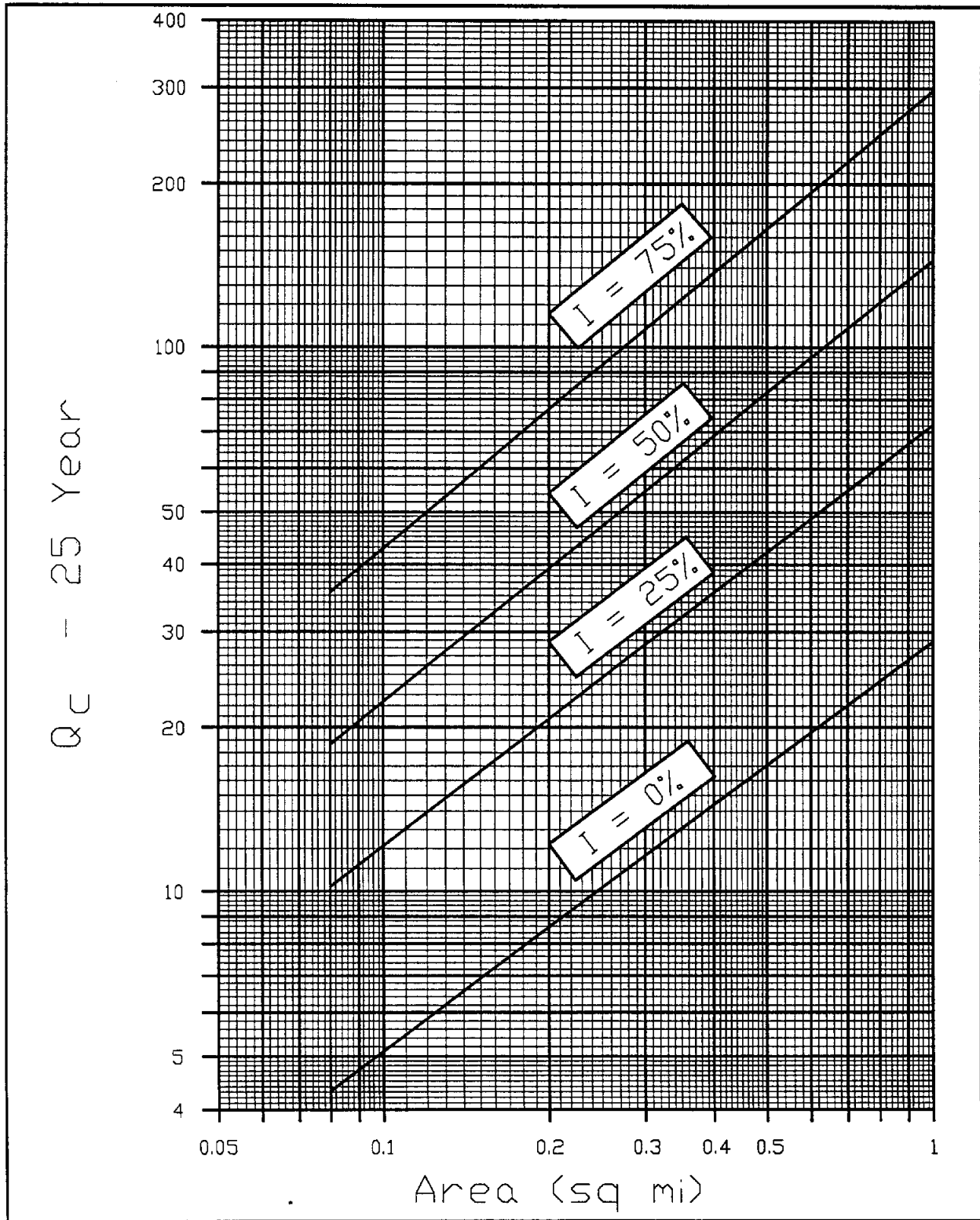

FIGURE 2.3 Montgomery County Runoff Rate Curves for 25-Year Storm

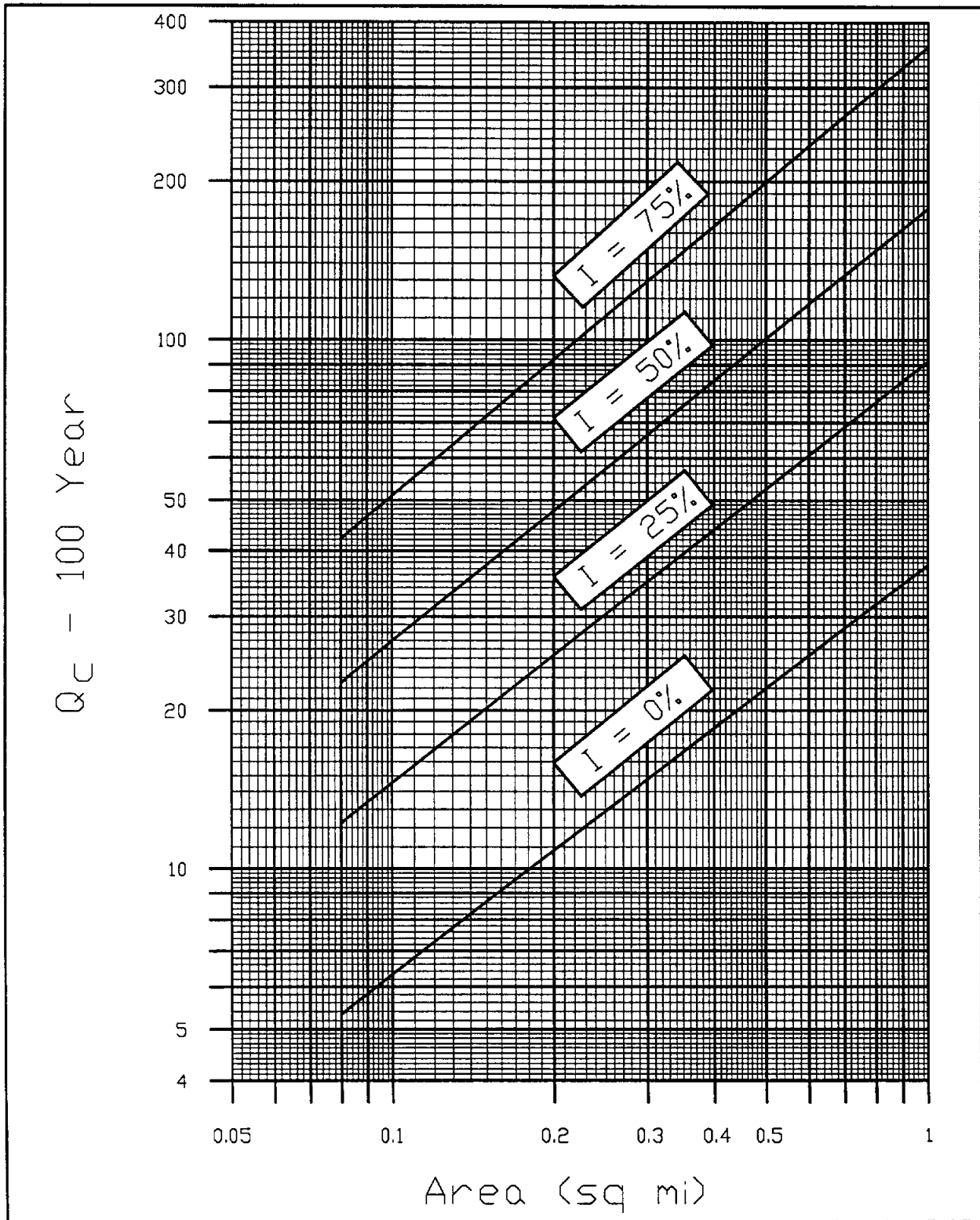

FIGURE 2.4 Montgomery County Runoff Rate Curves for 100-Year Storm

Table 2.8 lists the equations used in plotting the curves for Figures 2.3 and 2.4. These equations may be used in computer programs or spreadsheet templates to compute Q_c without using the plotted curves.

TABLE 2.8 Equations Used in Plotting Runoff Rate Curves

Percent Impervious, I	25-Year Equation for Q_c	100-Year Equation for Q_c
0	$Q_c = 28.8A^{0.752}$	$Q_c = 37.5A^{0.768}$
25	$Q_c = 72A^{0.771}$	$Q_c = 91A^{0.798}$
50	$Q_c = 145A^{0.813}$	$Q_c = 178A^{0.819}$
75	$Q_c = 300A^{0.846}$	$Q_c = 360A^{0.849}$

NOTE: A = Drainage Area in Square Miles

2.5.1.1 Use of Runoff Rate Curves

To use the Curves in Figures 2.3 and 2.4 to compute the peak rate of runoff from a drainage area for the 25-year and 100-year storm events, the following steps are required:

- 1) Determine the Drainage Area, Percent Impervious Cover, Average Channel Slope, Average Watershed Slope, and Weighted "n" Value for the channel. These are some of the same values used in determining the unit hydrograph parameters for use with HEC-1, as described in SECTION 2.6.3.
- 2) Using the Drainage Area, determine y-axis values Q_c from the two curves which bracket the Percent Impervious Cover for the drainage area. For example, the curves which bracket a watershed condition of 20% impervious are the curves for 0% impervious and 25% impervious.
- 3) Determine the values of the X , Y , and Z coefficients from Table 2.9.

TABLE 2.9 Parameters Used With Runoff Rate Curves

Percent Impervious, I	X	Y	Z
0	0.22	0.21	-0.61
25	0.16	0.17	-0.54
50	0.15	0.16	-0.47
75	0.13	0.14	-0.39

- 4) Compute the peak 25-year and 100-year flow rates for each of the two bracket values of percent impervious using the following equation:

$$Q_p = Q_c \times (S^X S_o^Y N^Z)$$

in which:

Q_p = Peak Flow Rate (cfs)

Q_c = Y-Axis Value from Figure 2.3 or 2.4

S = Channel Slope (ft/mi)

X = Value from Table 2.9

S_o = Watershed Slope (ft/mi)

Y = Value from Table 2.9

N = Weighted "n"

Z = Value from Table 2.9

5) Linearly interpolate the peak flow rate for the actual percent impervious value from the peak flow rates for the higher and lower percent impervious values.

Figure 2.5 is a worksheet which aids in the use of Figures 2.3 or 2.4 for flow rate computation.

When flow rates for storm events other than the 25-year and 100-year are required, plot the 25-year and 100-year flow rates on log-probability paper and connect them with a straight line. Interpolate or extrapolate as needed to determine the peak flow rate for the required storm frequency.

Applicable flow rates for existing conditions in the design of detention facilities should be determined on a case-by-case basis working closely with the County Drainage Administrator (See SECTION 7).

STEP 1: BACKGROUND INFORMATION

Watershed Name:
Location:
Comments:

STEP 2: WATERSHED DATA

Item	Symbol	Value	Source or Explanation
Drainage Area (sq mi)	A		See SECTION 2.6.3.
Impervious Cover (%)	I		See SECTION 2.6.3.
Channel Slope (ft/mi)	S		See SECTION 2.6.3.
Watershed Slope (ft/mi)	S_o		See SECTION 2.6.3.
Weighted "n"	N		See SECTION 2.6.3.

STEP 3: PEAK FLOW RATES FROM CURVES FOR LOWER AND HIGHER PERCENT IMPERVIOUS

Item	Lower I_1	Higher I_2	Source or Explanation
Percent Impervious Cover (%), I			0, 25, 50, 75, or 100%
Q_c			Figure 2.3 or 2.4
X			Table 2.9
Y			Table 2.9
Z			Table 2.9
Peak Flow Rates, Q_1 and Q_2	$Q_1 =$	$Q_2 =$	$Q_P = Q_C \times (S^X S_o^Y N^Z)$

STEP 4: INTERPOLATE PEAK FLOW RATE FOR ACTUAL PERCENT IMPERVIOUS

Item	Symbol	Value	Source or Explanation
Peak Flow Rate	Q_P		$Q_P = Q_1 + \left(\frac{I - I_1}{I_2 - I_1} \times (Q_2 - Q_1) \right)$

FIGURE 2.5 Blank Worksheet for Flow Rate Computation

2.5.1.2 Example Application of Runoff Rate Curves

Figure 2.6 illustrates an example watershed. The total watershed area is 535 acres or 0.84 square miles. A 54-acre development exists in the watershed.

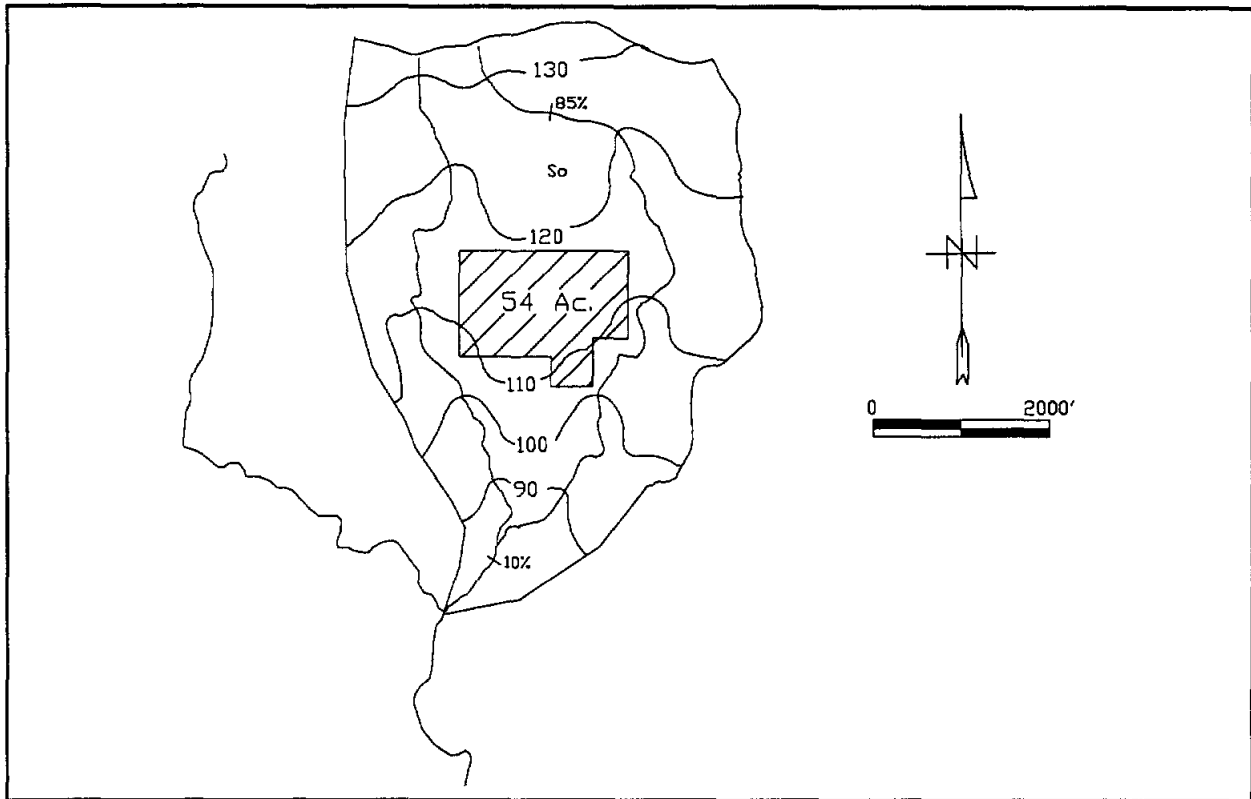

FIGURE 2.6 Example Watershed for Curve Flow Rates

The Percent Impervious is computed assuming that the 54-acre developed area is 50% impervious, and the remainder of the watershed is 0% impervious:

$$I = \frac{54 \text{ ac} \times 50\%}{535 \text{ ac}} = 5.1\%$$

The Channel Slope is computed for the middle 75% of the total watershed length. For this example, the measured elevations at the 10% and 85% points along the channel are used:

$$S = \frac{125' - 85'}{7060'} = 0.0057 \text{ ft/ft} = 29.9 \text{ ft/mi}$$

The Watershed Slope is computed using the change in elevation throughout the central part of the watershed. An average value is often obtained from measurements at several locations.

$$S_o = \frac{130' - 90'}{4800'} = 0.0083 \text{ ft/ft} = 44 \text{ ft/mi}$$

The Weighted Manning's n-Value for the channel is estimated from field observations of the channel condition. For this example, the weighted n-value is assumed to be 0.06. The Weighted n-Value can also be computed from a HEC-2 analysis of the channel, if one is available. This procedure is illustrated in SECTION 2.6.6.

Figure 2.7 presents a curve flow worksheet for the example watershed.

STEP 1: BACKGROUND INFORMATION

Watershed Name: Sample Watershed
Location: Southern Montgomery County
Comments: This is an example of a watershed analysis for a watershed larger than 50 acres but smaller than 640 acres. This is a 100-year storm analysis - Use Figure 2.4.

STEP 2: WATERSHED DATA

Item	Symbol	Value	Source or Explanation
Drainage Area (sq mi)	A	0.84	See SECTION 2.6.3.
Impervious Cover (%)	I	5.1%	See SECTION 2.6.3.
Channel Slope (ft/mi)	S	29.9	See SECTION 2.6.3.
Watershed Slope (ft/mi)	S_o	44.0	See SECTION 2.6.3.
Weighted "n"	N	0.06	See SECTION 2.6.3.

STEP 3: PEAK FLOW RATES FROM CURVES FOR LOWER AND HIGHER PERCENT IMPERVIOUS

Item	Lower I_1	Higher I_2	Source or Explanation
Percent Impervious Cover (%), I	0%	25%	0, 25, 50, 75, or 100%
Q_c	32	78	Figure 2.3 or 2.4
X	0.22	0.16	Table 2.9
Y	0.21	0.17	Table 2.9
Z	-0.61	-0.54	Table 2.9
Peak Flow Rates, Q_1 and Q_2	$Q_1 = 832$	$Q_2 = 1,168$	$Q_P = Q_C \times (S^X S_o^Y N^Z)$

STEP 4: INTERPOLATE PEAK FLOW RATE FOR ACTUAL PERCENT IMPERVIOUS

Item	Symbol	Value	Source or Explanation
Peak Flow Rate	Q_P	901	$Q_P = Q_1 + \left(\frac{I - I_1}{I_2 - I_1} \times (Q_2 - Q_1) \right)$

FIGURE 2.7 Example Worksheet for Flow Rate Computation

2.5.2 Hydrograph Development

A technique for hydrograph development which is useful in the design of detention facilities serving relatively small watersheds has been presented by H.R. Malcom [Malcom, Undated]. This procedure can be used in conjunction with the drainage area-discharge curves (discussed later) or the Rational Method. The methodology utilizes a pattern hydrograph to obtain a curvilinear design hydrograph which peaks at the design flow rate and which contains a runoff volume consistent with the design rainfall. The pattern hydrograph is a step function approximation to the dimensionless hydrograph proposed by the Bureau of Reclamation and the Soil Conservation Service [SCS, 1972].

Malcom's Method consists of the following equations:

$$T_p = \frac{V}{1.39Q_p} \quad \text{Equation 2.7}$$

$$q_i = \left(\frac{Q_p}{2}\right) \left(1 - \cos\left(\frac{\pi t_i}{T_p}\right)\right) \quad t_i \leq 1.25T_p \quad \text{Equation 2.8}$$

$$q_i = 4.34Q_p e^{\left(-1.3\frac{t_i}{T_p}\right)} \quad t_i > 1.25T_p \quad \text{Equation 2.9}$$

in which:

Q_p = peak design flow rate in cfs

T_p = time to Q_p in seconds

V = total volume of runoff for the design storm in cubic feet

The variables t_i and q_i are the respective time and flow rates which determine the shape of the hydrograph.

In Equation 2.8, the argument of the COS function must be expressed in radians, not degrees.

A hydrograph plot which illustrates the parameters involved in the development of hydrographs using the Malcom Method is included as Figure 2.8.

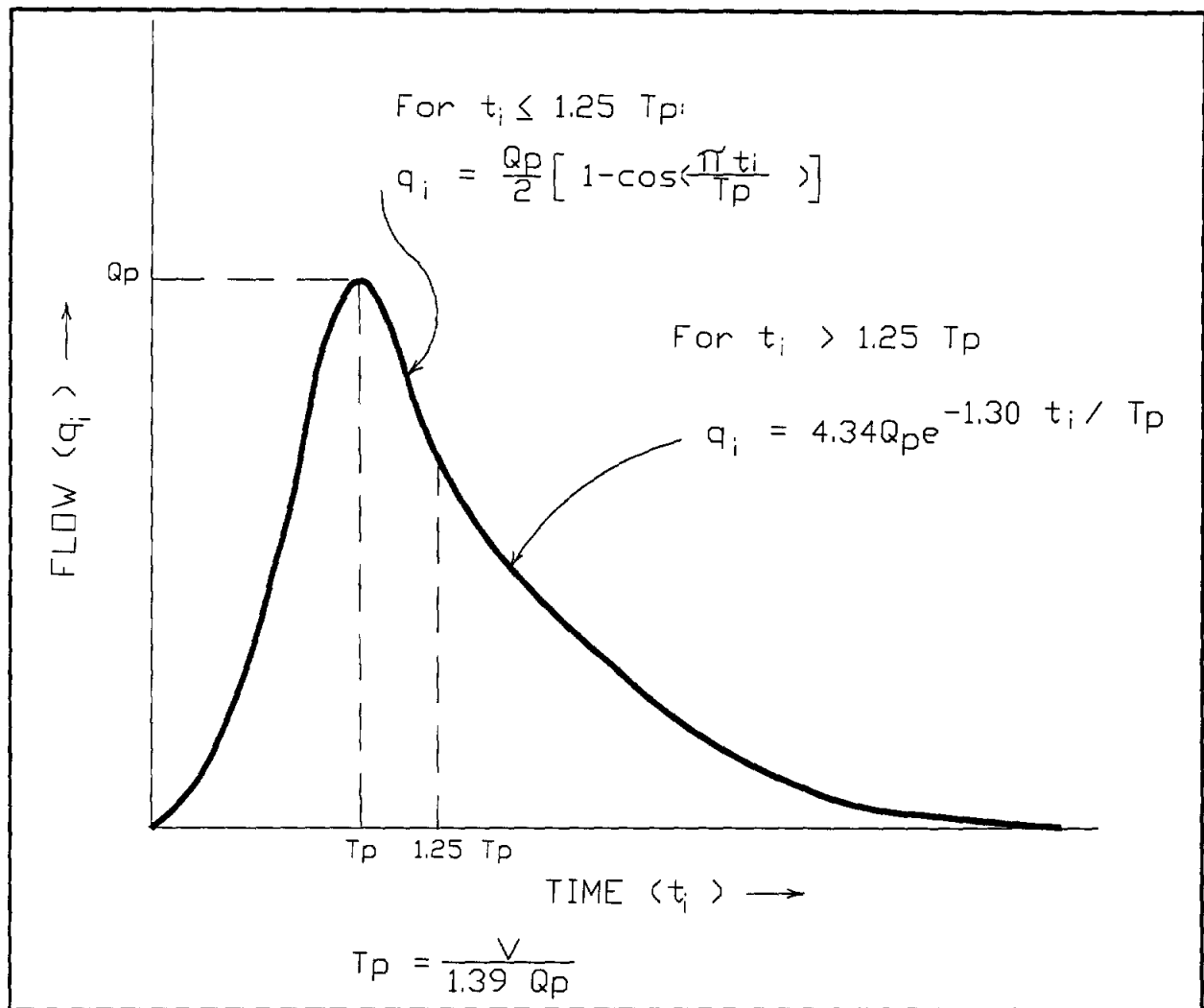

FIGURE 2.8 Malcom Method Hydrograph

2.5.2.1 Peak Flow Rates for Hydrograph Development

The peak design flow rate can be calculated directly, either from the Montgomery County Runoff Rate curves or the Rational Method, depending upon the size of the area considered.

2.5.2.2 Total Runoff Volume for Hydrograph Development

The total volume of runoff is dependent on the characteristics of the soil and the degree of urbanization of the area (i.e. percent of impervious cover). Loss rate totals may be estimated using the **SCS Curve Number** methodology developed by the Soil Conservation Service [SCS, 1972].

Figure 2.9 provides graphs for the determination of runoff volume for a given rainfall depth and SCS Curve Number.

The SCS provides information on relating soil group type to curve number as a function of soil cover, land use type and antecedent moisture conditions. The SCS soil classification system uses four groups, as follows:

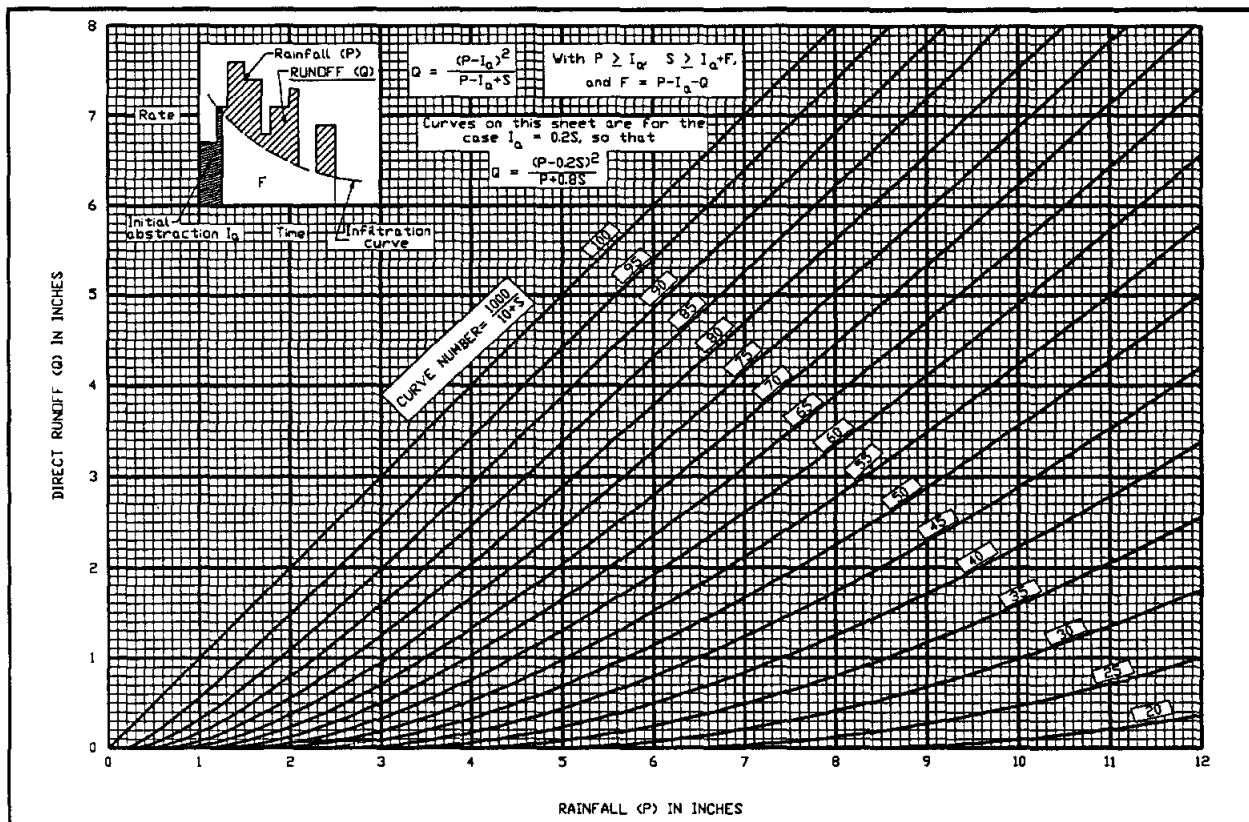

FIGURE 2.9 Determination of Runoff Volume Using SCS Curve Number

Group A: deep sand, deep loess, aggregated silts

Group B: shallow loess, sandy loam

Group C: clay loams, shallow sandy loam, soils low in organic content, and soils usually high in clay.

Group D: soils that swell significantly when wet, heavy plastic clays, and certain saline soils.

All other factors being equal, Group A soils have the lowest runoff potential and Group D soils have the highest runoff potential.

Usually, the best source of information for determining the SCS soil group for a particular drainage area is the *Soil Survey of Montgomery County, Texas* [SCS, 1972].

Tables 2.10 and 2.11 of this manual lists appropriate values for the SCS Curve Number for each of the four SCS soil groups. The tables are also organized according to the SCS cover complex, which consists of three factors: land use, land treatment or practice, and hydrologic condition. For example, the land use for a particular area may be "Row crops". If the land treatment or practice is "Straight row" and the hydrologic condition is "Good", then the SCS Curve Number would range from 67 to 89, depending on the soil group.

TABLE 2.10 Values of SCS Curve Number for Rural Areas

Land Use Description	Hydrologic Soil Group:			
	A	B	C	D
Fallow				
Straight Row	77	86	91	94
Row Crops				
Straight Row, Poor Condition	72	81	88	91
Straight Row, Good Condition	67	78	85	89
Contoured, Poor Condition	70	79	84	88
Contoured, Good Condition	65	75	82	86
Contoured and Terraced, Poor Condition	66	74	80	82
Contoured and Terraced, Good Condition	62	71	78	81
Small Grain				
Straight Row, Poor Condition	65	76	84	88
Straight Row, Good Condition	63	75	83	87
Contoured, Poor Condition	63	74	82	85
Contoured, Good Condition	61	73	81	84
Contoured and Terraced, Poor Condition	61	72	79	82
Contoured and Terraced, Good Condition	59	70	78	81
Close-Seeded Legumes or Rotation Meadow				
Straight Row, Poor Condition	66	77	85	89
Straight Row, Good Condition	58	72	81	85
Contoured, Poor Condition	64	75	83	85
Contoured, Good Condition	55	69	78	83
Contoured and Terraced, Poor Condition	63	73	80	83
Contoured and Terraced, Good Condition	51	67	76	80
Pasture or Range				
Poor Condition	68	79	86	89
Fair Condition	49	69	79	84
Good Condition	39	61	74	80
Contoured, Poor Condition	47	67	81	88
Contoured, Fair Condition	25	59	75	83
Contoured, Good Condition	6	35	70	79
Meadow, Good Condition	30	58	71	78
Woods or Forest Land				
Poor Condition	45	66	77	83
Fair Condition	36	60	73	79
Good Condition	25	55	70	77
Farmsteads	59	74	82	86

Source: [McCuen, 1982]

TABLE 2.11 Values of SCS Curve Number for Urban and Suburban Areas

Land Use Description	Hydrologic Soil Group			
	A	B	C	D
Residential				
1/8 acre or less average lots (65% impervious)	77	85	90	92
1/4 acre average lots (38% impervious)	61	75	83	87
1/3 acre average lots (35% impervious)	57	72	81	86
1/2 acre average lots (25% impervious)	54	70	80	85
1 acre average lots (20% impervious)	51	68	79	84
Paved parking lots, roofs, driveways, etc.	98	98	98	98
Streets and Roads				
Paved with curbs and storm sewers	98	98	98	98
gravel	76	85	89	91
dirt	72	82	87	89
Commercial & Business Areas (85% Impervious)	89	92	94	95
Industrial Districts (72% Impervious)	81	88	91	93
Open Spaces, Lawns, Parks, Golf Courses, Cemeteries, etc.				
good condition: grass cover on 75% or more	39	61	74	80
fair condition: grass cover on 50% to 75%	49	69	79	84

Source: [McCuen, 1982]

2.5.2.3 Example of Hydrograph Development for Small Watersheds

As an example of the Malcom method of developing a hydrograph, we will develop a runoff hydrograph for the watershed used for the example application of the runoff rate curves (see SECTION 2.5.1.2).

According to Table 2.4, the 100-year, 24-hour rainfall total for Montgomery County is 12.17 inches. Assume that the Soil Survey for Montgomery County indicates that the soils in the watershed are predominately SCS Soil Group C. The undeveloped portion of the watershed consists of woodlands in good condition. Therefore, according to Table 2.10, the SCS Curve Number should be about 70.

Referring to Figure 2.9, the total runoff volume from the undeveloped portion of the watershed is 8.2 inches. However, there are no infiltration losses for the 5.1% of the watershed which is impervious, so the runoff from that area is 12.17 inches. Therefore, the runoff volume in cubic feet is computed as follows:

$$V_1 = 94.9\% \times 535 \text{ ac} \times 43,560 \text{ sf/ac} \times 8.20 \text{ in} + 12 \text{ in/ft} = 15.11 \text{ million cubic feet}$$

$$V_2 = 5.1\% \times 535 \text{ ac} \times 43,560 \text{ sf/ac} \times 12.17 \text{ in} + 12 \text{ in/ft} = 1.21 \text{ million cubic feet}$$

$$V = V_1 + V_2 = 16.32 \text{ million cubic feet}$$

The time to peak is computed using Equation 2.7:

$$T_p = \frac{V}{1.39Q_p}$$

$$T_p = 16,320,000 \text{ cu ft} + (1.39 \times 901 \text{ cu ft/sec} \times 60 \text{ sec/min}) = 222 \text{ min}$$

The computed time interval for hydrograph computations is $T_p/10$.

$$t = 137 + 10 = 22 \text{ min}$$

For convenience, the computed hydrograph will be based on 20-minute intervals. For $t_i \leq 1.25T_p$ (277.5 minutes), use equation 2.5. For $t_i > 1.25T_p$ (277.5 minutes), use equation 2.6. Table 2.12 lists the computed runoff hydrograph.

TABLE 2.12 Computed Runoff Hydrograph for Example Watershed

Time t (min)	Time t (min)	Flow Rate q (cfs)	Equation Used
0	0.00	0	2.8
20	0.33	19	2.8
40	0.67	73	2.8
60	1.00	160	2.8
80	1.33	270	2.8
100	1.67	395	2.8
120	2.00	525	2.8
140	2.33	649	2.8
160	2.67	756	2.8
180	3.00	838	2.8
200	3.33	887	2.8
220	3.67	901	2.8
240	4.00	876	2.8
260	4.33	816	2.8
280	4.67	731	2.9
300	5.00	648	2.9
320	5.33	575	2.9
340	5.67	510	2.9
360	6.00	452	2.9
380	6.33	401	2.9
400	6.67	356	2.9
420	7.00	316	2.9
440	7.33	280	2.9
460	7.67	249	2.9

2.6 HYDROLOGIC ANALYSIS OF WATERSHEDS LARGER THAN 640 ACRES

Hydrologic analyses of watersheds larger than 640 acres shall be completed using the HEC-1 computer program. A stream network model which simulates the runoff response of a drainage basin to rainfall over that basin can be developed with the HEC-1 computer program through the appropriate combination of runoff and routing computations. The following sections describe the elements required to develop a HEC-1 computer model.

2.6.1 Precipitation Data

Design storm rainfall can be described in terms of frequency, duration, areal extent and distribution of intensity with time. The distribution of design rainfall with respect to time is handled by the HEC-1 program by assuming a symmetrical, single-peaked design *hyetograph* (storm distribution). The engineer's choice of storm frequency and duration is dependent upon the physical characteristics and location of the watershed, as well as the study objectives. In most cases, design computations will be based on a 24-hour duration storm event.

The HEC-1 program has the capability to modify rainfall hyetographs to account for progressively smaller design rainfall amounts as areal coverage increases. The HEC-1 users manual [HEC, 1987] suggests methods for defining storm rainfall depth versus drainage area relationships based on Figure 15 in U.S. Weather Bureau Technical Paper No. 40 [Hershfield, 1961], which presents a means of reducing point rainfall amounts as drainage area increases. Figure 2.10 illustrates the storm distribution computed by HEC-1 for a 24-hour storm event in Montgomery County, assuming a 1-hour computation interval.

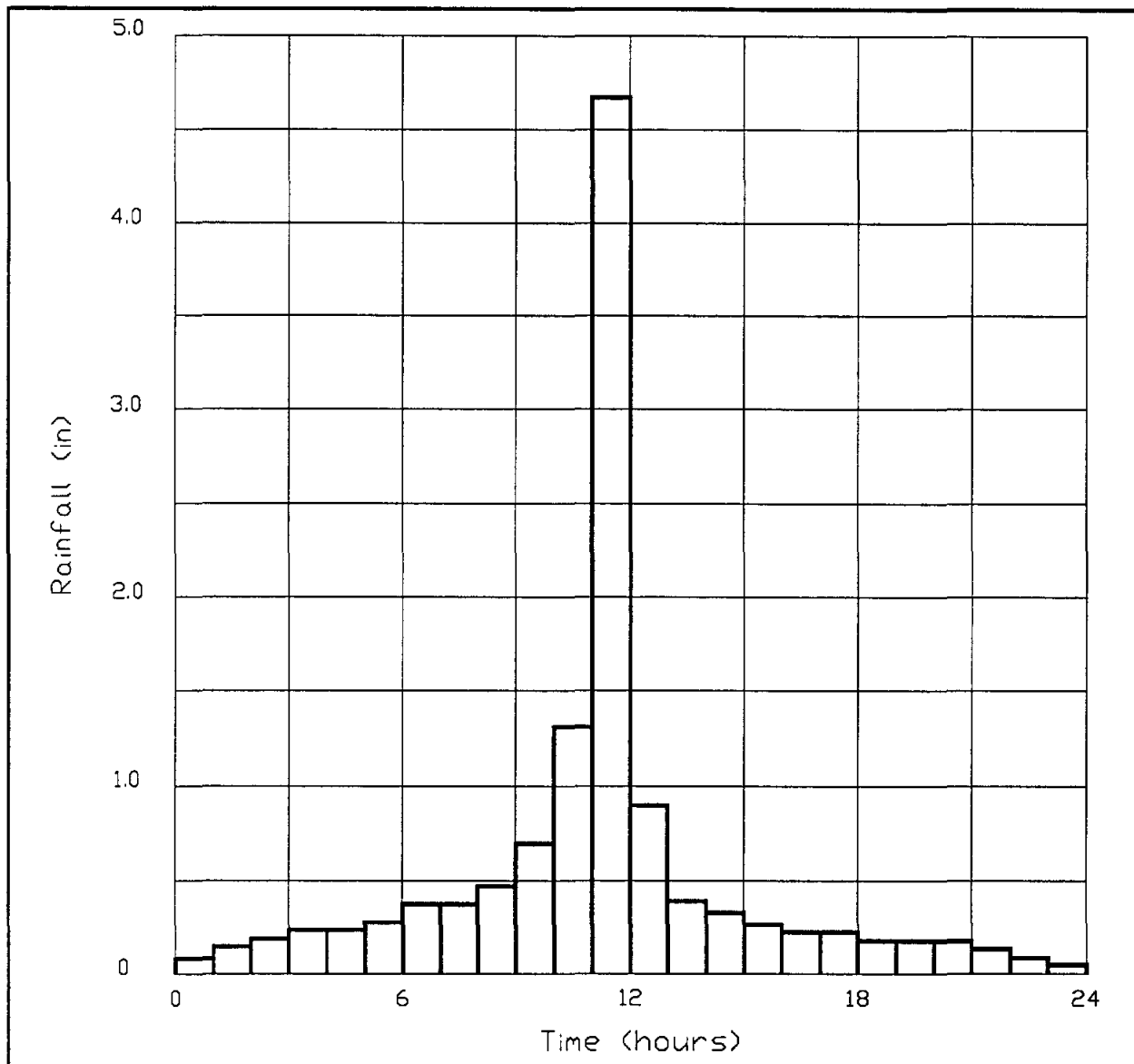

FIGURE 2.10 Typical HEC-1 Storm Distribution

It is often necessary to increment design rainfall hyetographs in intervals of less than one hour to meet the design needs of small drainage areas having short times of concentration. The TP-40 rainfall isopleth maps are limited to storm durations of 30 minutes or more. Table 3 of TP-40 then provides a method to calculate the rainfall amounts for shorter duration storms based on national average values. To more accurately define these rainfall quantities on a local basis, the National Weather Service issued Technical Memorandum NWS Hydro-35 [Frederick, 1977]. Thus, both TP-40 and Hydro-35 are used to develop Table 2.4 in which rainfall depth vs. duration data are presented for a variety of storm frequencies. Table 2.4 is also useful when utilizing the Rational Method.

2.6.2 Precipitation Loss Computations

Only a portion of the rainfall which occurs over a watershed during a storm event actually becomes runoff. The remainder is intercepted by infiltration, depression storage, evaporation and other mechanisms. The portion of rainfall which becomes runoff is termed the **excess rainfall**. The difference between the observed total rainfall hyetograph and the excess rainfall hyetograph is termed **abstraction**, or **loss**.

The recommended procedure for calculating abstractions in Montgomery County is the exponential loss rate function contained in HEC-1. This is an empirical method in which the loss rate is determined to be a function of both the rainfall intensity and accumulated losses. The HEC-1 user's manual contains a detailed discussion of the relevant equations and variables [HEC, 1981]. Figure 2.11 illustrates the HEC-1 exponential loss rate function and its parameters.

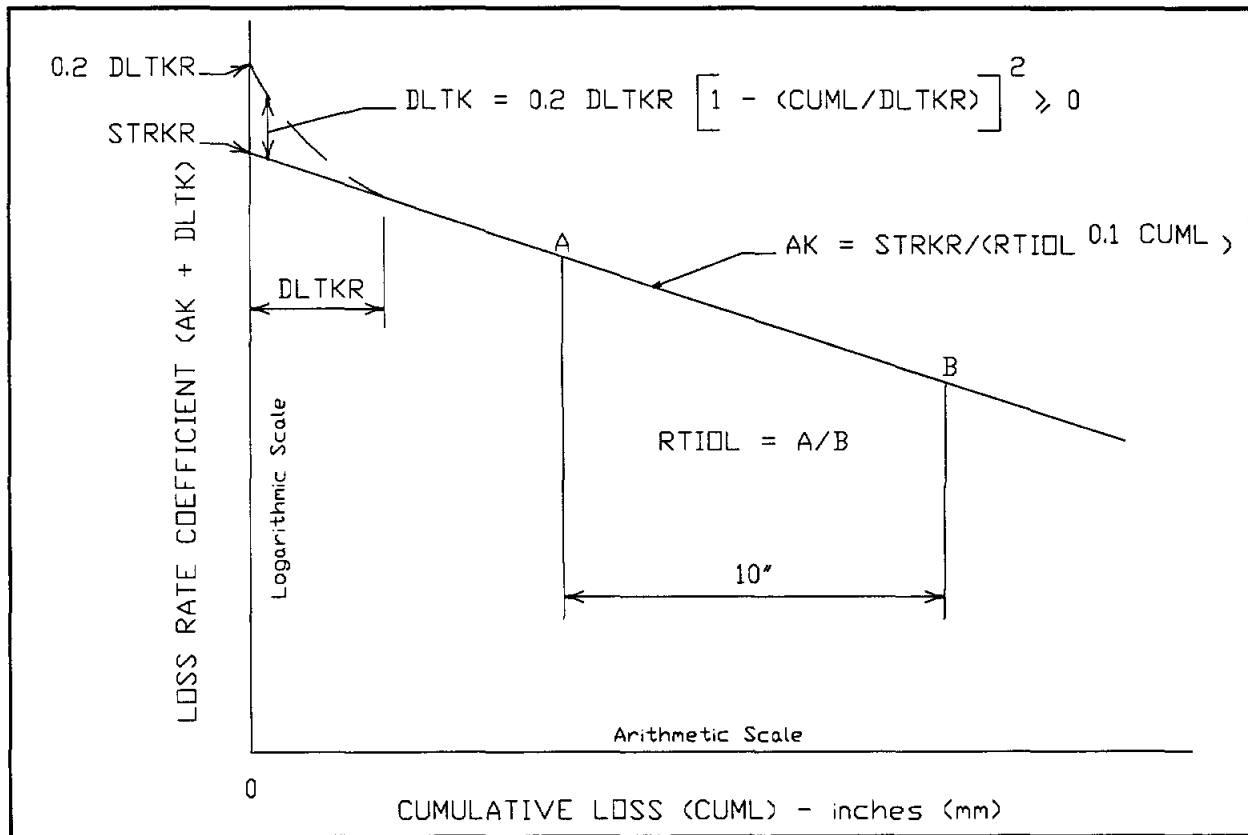

FIGURE 2.11 HEC-1 Exponential Loss Rate Function

Based on analyses conducted in the development of the hydrologic methodology for Harris County and a consideration of soil characteristics in Montgomery County, Table 2.13 lists recommended values for the variables to be used with this methodology.

TABLE 2.13 Recommended Values for HEC-1 Loss Parameters

HEC-1 Variable Name	Recommended Values
STRKR	0.2
DLKTR	2.5
RTIOL	2.0
ERAIN	0.55
RTIMP	(Percent Urban Development) x (Average Percent Impervious in Developed Area) / 100

Note: The value of RTIMP, which is expressed in percent, is equal to 100 times the effective impervious ratio (*I*) in equation 2.7.

Typical values for the percentage of impervious cover corresponding to various types of development are given in Table 2.14. These values should be used when only the general type of planned development is known; once the actual level of development has been determined for a specific area, a refined value should be used to reflect the actual percent of impervious cover.

TABLE 2.14 Typical Average Values for Impervious Cover

Type of Development	Percentage of Impervious Cover
Commercial and Business Areas	85
Industrial Areas	72
Residential Areas, Average lot size 1/8 Acre or less	65
Residential Areas, Average lot size 1/4 Acre	38
Residential Areas, Average lot size 1/3 Acre	30
Residential Areas, Average lot size 1/2 Acre	25
Residential Areas, Average lot size 1 Acre	20

Source: SCS TR-55 [SCS, 1986]

2.6.3 Unit Hydrograph Procedure

Given the design storm excess rainfall, it is necessary to determine the storm runoff hydrograph at the point of interest utilizing the HEC-1 program. A **unit hydrograph** represents the hydrologic response of a watershed to excess rainfall. The HEC-1 computer program can use several unit hydrograph methods, including the Clark method. The *Handbook of Applied Hydrology* [Chow, 1964] provides a detailed discussion of unit hydrograph theory and application.

The Clark unit hydrograph for a drainage area is described by three parameters: *TC*, *R* and a time-area curve. *TC* represents the time of concentration and *R* is a storage coefficient for the area. The time-area curve defines the cumulative area of the watershed contributing runoff to the design point as a function of time. Figure 2.12 illustrates the Clark Unit Hydrograph and its parameters.

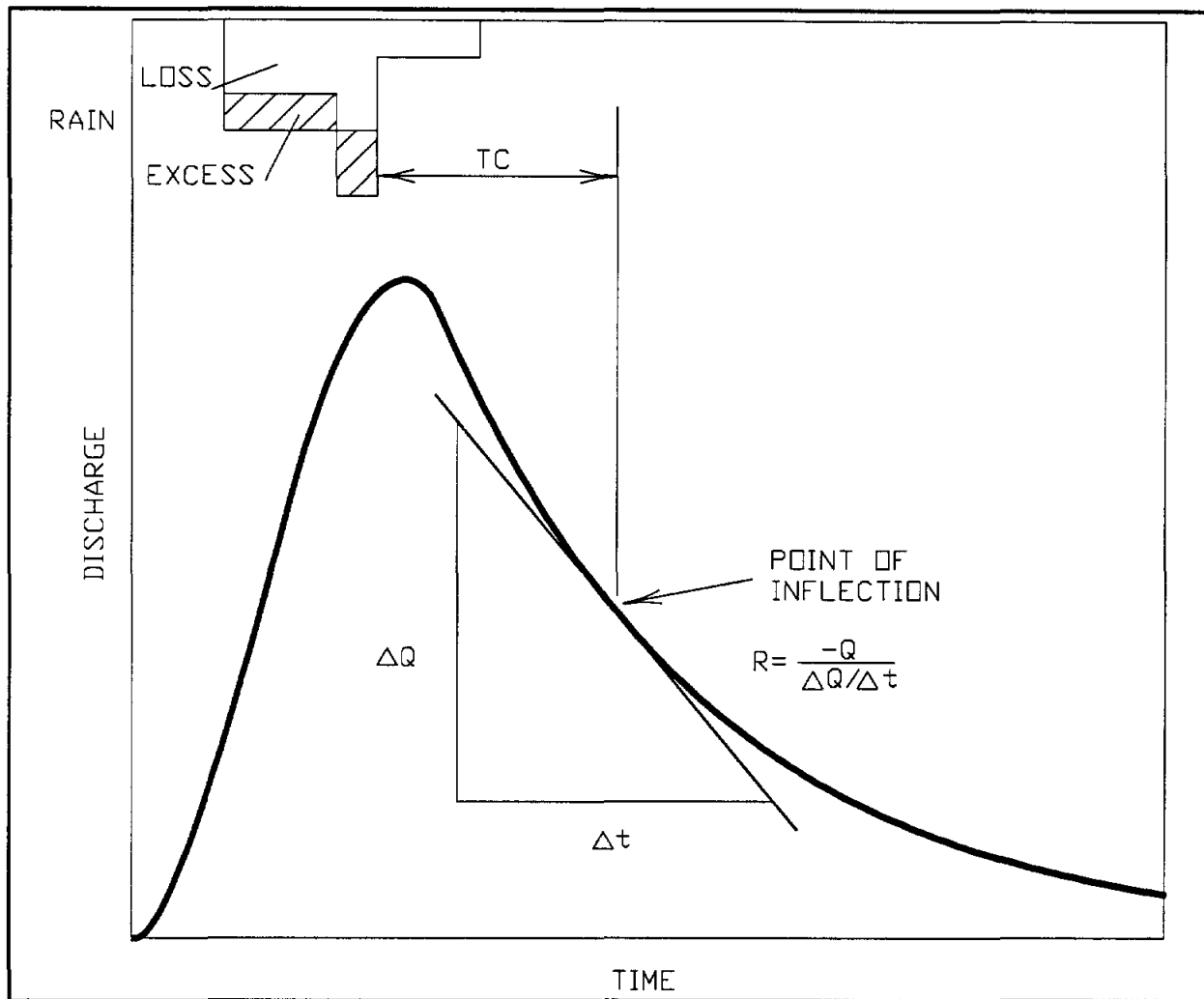

FIGURE 2.12 HEC-1 Clark Unit Hydrograph

A statistical analysis of historical rainfall and runoff data taken from selected watersheds in Harris, Fort Bend, and Montgomery Counties was performed by Espey, Huston & Associates, Inc. in 1987 to correlate TC and R to physical drainage area characteristics [EHA, 1987]. These characteristics include the length, slope and roughness of the basin's longest watercourse, the average overland slope, and the imperviousness of the basin. From this analysis, the following equations were derived:

$$TC + R = \frac{128 \left(\frac{L}{\sqrt{S}} \right)^{0.57} (N)^{0.8}}{(S_o)^{0.11} (10)^f} \quad \text{Equation 2.10}$$

$$TC = (TC + R) \times 0.38(\log S_o) \quad \text{Equation 2.11}$$

$$R = (TC + R) - TC \quad \text{Equation 2.12}$$

in which:

TC = Clark's time of concentration

R = Clark's storage coefficient

L = *Length*: The length of the longest watercourse within the subarea to the watershed divide, in miles.

S = *Channel Slope*: The average slope of the middle 75% of the longest watercourse in the subarea, in feet per mile.

N = *Manning's Weighted "n"*: The Manning's roughness coefficient as a weighted average value representative of flow roughness in the subarea's main watercourse. It should account for portions of the design flow contained in the overbanks as well as the main channel. A recommended simplified procedure is to divide the basin into upstream and downstream halves, determine the representative composite "n" value for a typical section in each half, then weight the upstream value 25% and the downstream value 75%.

S_o = *Average Basin Slope*: The average slope of the land in the watershed, in feet per mile.

I = *Effective Impervious Ratio*: Determined by:

$$I = \frac{\sum(CD)}{A_T} \times 10^{-2} \quad \text{Equation 2.13}$$

in which:

A_T = Total drainage area

C = Average percent of impervious cover of a developed area (in percent)

D = Area that is developed

Determination of TC and R is carried out by the solution of Equations 2.10, 2.11 and 2.12. These parameters may then be input into the HEC-1 program to model the runoff process. A time-area curve is generated internally by HEC-1 unless the engineer specifies a particular time-area relationship.

2.6.4 Adjustment for Ponding

A **ponding area** is an area where runoff is retarded from reaching a watercourse due to obstructions or natural storage. Such obstructions include leveed fields (rice farms), swamps, etc. The presence of significant areas of ponding in a drainage sub-area has a pronounced effect on the nature of the runoff hydrograph from that sub-area. Storage in ponding areas tends to cause peak flow rates to be decreased and the time at which the peak flow occurs to be delayed. To account for this effect, an adjustment can be made in the Clark storage coefficient (R).

The determination of adjusted storage coefficients may be accomplished through a two-step process. First, the basic adjustment factor RM is determined using the equation:

$$RM = XP^Y$$

in which:

P = *Ponded Area*: The area where leveed agricultural areas (especially rice fields) retard runoff from reaching a watercourse, expressed as a percentage.

X, Y = Values defined in Table 2.15.

For example, if a sub-area of ten square miles has two square miles of ponded area, the percent ponding would be 20%. Using the 100-year Adjustment Factor equation from Table 2.15, the appropriate adjustment factor is computed as 1.80.

For the second step of the ponding adjustment process, the basic adjustment factor RM is modified using the following equation:

TABLE 2.15 Coefficients for Computing Ponding Adjustment Factor (*RM*)

Storm Event	X	Y
5-Year	1.31	0.214
10-Year	1.28	0.199
25-Year	1.25	0.171
50-Year	1.23	0.153
100-Year	1.21	0.132
500-Year	1.17	0.086

Source: [EHA, 1987]

$$R_p = \left[(RM - 1.0) \times \left(\frac{AP}{100} \right) \right] + 1.0$$

in which:

R_p : The modified adjustment factor

AP = Area Affected by Ponding: The total area affected by ponding, including the ponded area itself and the area which must drain through the ponded area, expressed as a percentage of the total watershed area.

If, for instance, an additional one square mile of the ten square mile sub-area drains through the two square mile ponding area, only 30% of the entire drainage sub-area is affected by ponding. The adjustment factor would thus be reduced by 70%:

$$[(1.80 - 1.0) \times 0.30] + 1.0 = 1.24$$

The adjusted Clark storage coefficient may now be computed as:

$$R_A = R \times R_p$$

2.6.5 Streamflow Routing Procedure

As a flood wave passes downstream through a channel or detention facility, it is altered due to the effects of storage and travel time. The procedure for determining how the shape of the flood hydrograph changes is termed **flood routing**.

Flood routing can be classified into two broad but related categories: open channel routing and reservoir routing. **Reservoir routing** is generally used to determine the effectiveness of stormwater detention, which reduces downstream peak flow rates. **Open channel routing** is a refinement of the description of an area's rainfall-runoff process. It modifies the time rate of runoff due to storage and travel time within the channel and its overbanks. Analysis of areas with very flat overbanks and wide flood plains should include channel routing to determine possible peak discharge attenuation and lagging.

The recommended technique for both channel and reservoir routing is the **Modified Puls** method. The Modified Puls method is based on the assumption of an invariable discharge-storage relationship and a constant level pool in the storage reach of interest. The HEC-1 program provides a routine for this flood routing technique. The required storage-discharge relationships for this routing technique can be obtained through use of the HEC-2 backwater program for a variety of flow conditions. Care must be taken in developing these storage-discharge relationships with HEC-2. Cross-sections should be provided to adequately define all of the flood plain storage available at various water levels. However, only the effective area of the cross-section should be used to establish the proper discharge-water level relationship. For a detailed discussion of the Modified Puls routing technique and other methodologies, the engineer is referred to the *Handbook of Applied Hydrology* [Chow, 1964].

2.6.6 Example of HEC-1 Analysis

Figure 2.13 presents an example watershed and illustrates the methods used to determine values of the various watershed parameters. Table 2.16 lists the pertinent data for the watershed.

TABLE 2.16 Parameters for Example Watershed

Watershed Parameter	Symbol	Value
Watershed Area	A	2.13 sq mi
Percent Urban Development	D	57%
Average Basin Slope	S_o	36 ft/mi
Average Channel Slope	S	25.8 ft/mi
Longest Water Course Length	L	2.84 mi
Ponded Area	P	0.107 sq mi = 5.02%
Area Affected by Ponding		0.198 sq mi = 9.30%

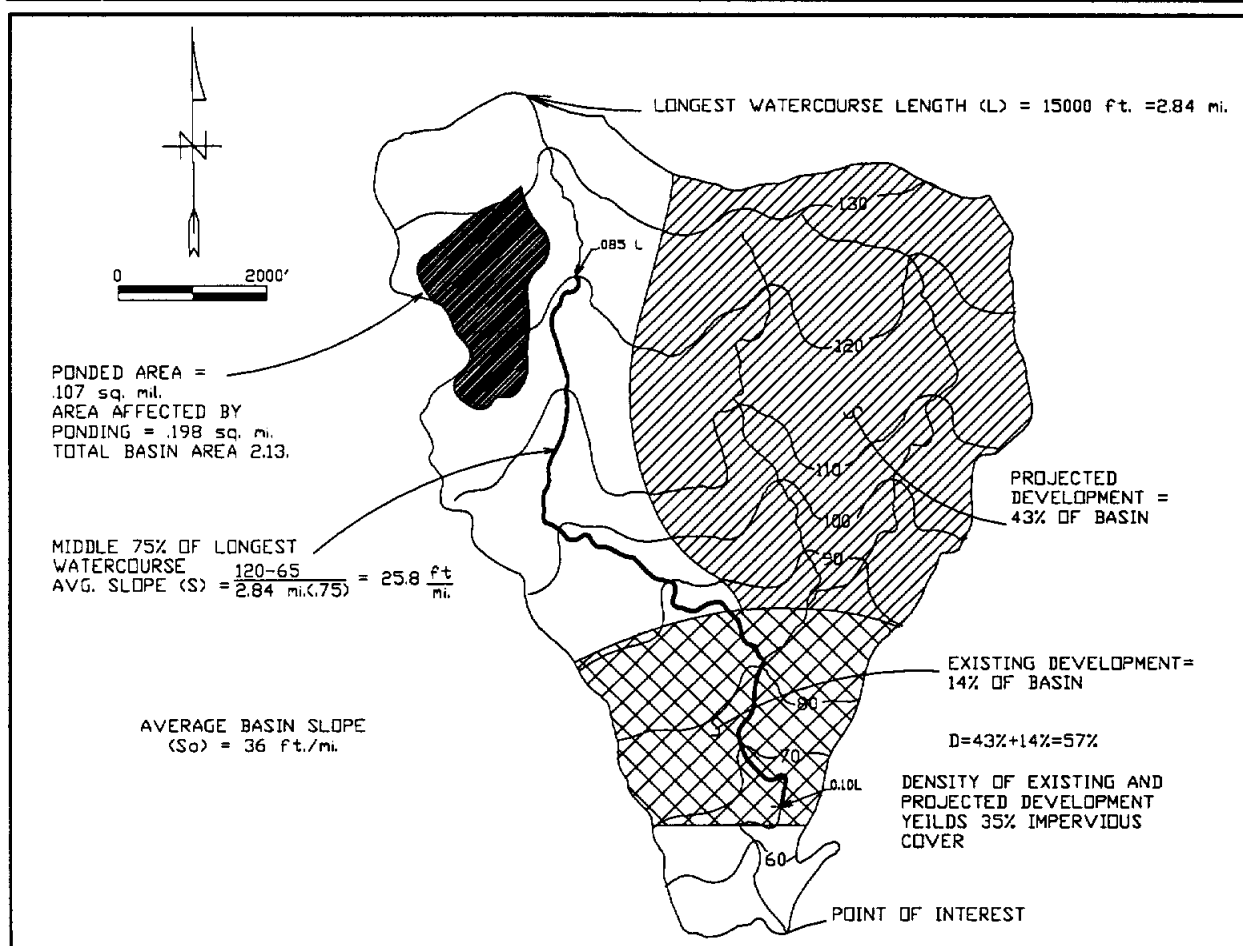

FIGURE 2.13 Example Watershed Map

The composite "n" value for the watershed is computed considering average channel cross-sections in the upstream and downstream portions of the watershed. Figure 2.14 illustrates an average channel cross-section in the upstream portion of the watershed. For the example watershed, this cross-section represents about 25% of the total channel length. At this cross-section, approximately 65% of the total flow occurs in the main channel. Therefore the composite "n" value for the upstream cross-section is:

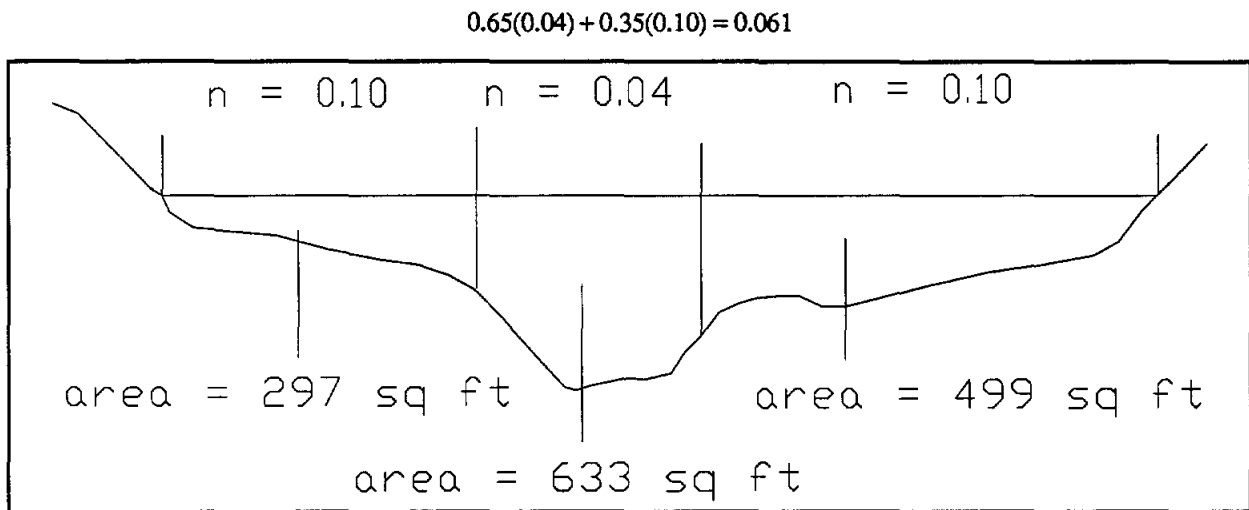

FIGURE 2.14 Average Upstream Channel Cross-Section

Figure 2.15 illustrates an average channel cross-section in the downstream portion of the watershed. For the example watershed, this cross-section represents about 75% of the total channel length. At this cross-section, approximately 55% of the total flow occurs in the main channel. Therefore the composite "n" value for the downstream cross-section is:

$$0.55(0.04) + 0.45(0.06) = 0.049$$

The composite "n" value for the entire channel is computed as follows:

$$N = 0.25(0.061) + 0.75(0.049) = 0.052$$

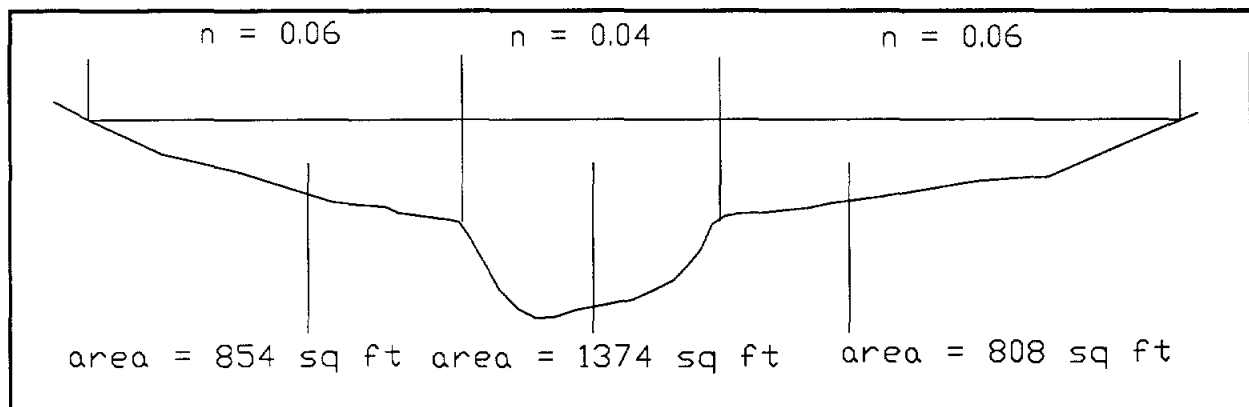

FIGURE 2.15 Average Downstream Channel Cross-Section

The Percent Impervious, I , is computed from the percent urban development for the watershed by multiplying the percent urban development by 0.35. Fully developed areas of the watershed are assumed to be 35% impervious:

$$I = 0.57 \times 0.35 = 0.20$$

The value of $TC + R$ is computed using Equation 2.10:

$$TC + R = \frac{128 \left(\frac{2.84}{\sqrt{25.8}} \right)^{0.57} (0.052)^{0.8}}{(36)^{0.11} (10)^{0.20}} = \frac{128 \times 0.3725 \times 0.09393}{1.4832 \times 1.5849} = 1.91$$

The Clark time of concentration, TC , is computed using Equation 2.11:

$$TC = 1.91 \times 0.38(\log 36) = 1.16$$

The Clark watershed storage coefficient, R , is computed using Equation 2.12:

$$R = 1.91 - 1.16 = 0.75$$

For the 100-year frequency storm, the Ponding Storage Adjustment Factor, RM , is computed using the 100-year equation from Table 2.15:

$$RM = 1.21(5.02)^{0.13} = 1.49$$

The Modified Storage Adjustment Factor, RM , is computed as follows:

$$RM = [(1.49 - 1.0) \times 0.093] + 1.0 = 1.05$$

The Modified Clark watershed storage coefficient, R , is computed as follows:

$$R = 0.75 \times 1.05 = 0.79$$

Figure 2.16 illustrates the HEC-1 output from the analysis of the sample watershed for the 24-hour duration, 100-year frequency storm event, under proposed conditions.

LINE	ID	HEC-1 INPUT										PAGE 1
1	ID	1	2	3	4	5	6	7	8	9	10	
2	ID	Example HEC-1 Analysis										
3	ID	Montgomery County Drainage Criteria Manual										
4	ID	June 1989 - Dodson & Associates, Inc.										
5	IT	15	01FEB89	0000	300							
6	IO	3										
7	KK	SAMPLE										
8	KM	SAMPLE WATERSHED RUNOFF HYDROGRAPH										
9	BA	2.13										
10	PH	1	0.89	3.24	4.52	5.94	6.80	8.38	10.38	12.26		
11	LE	0.2	2.5	2.0	0.55	20						
12	UC	1.16	0.79									
12	ZZ											

FIGURE 2.16A Example Watershed HEC-1 Output - Input Data Listing

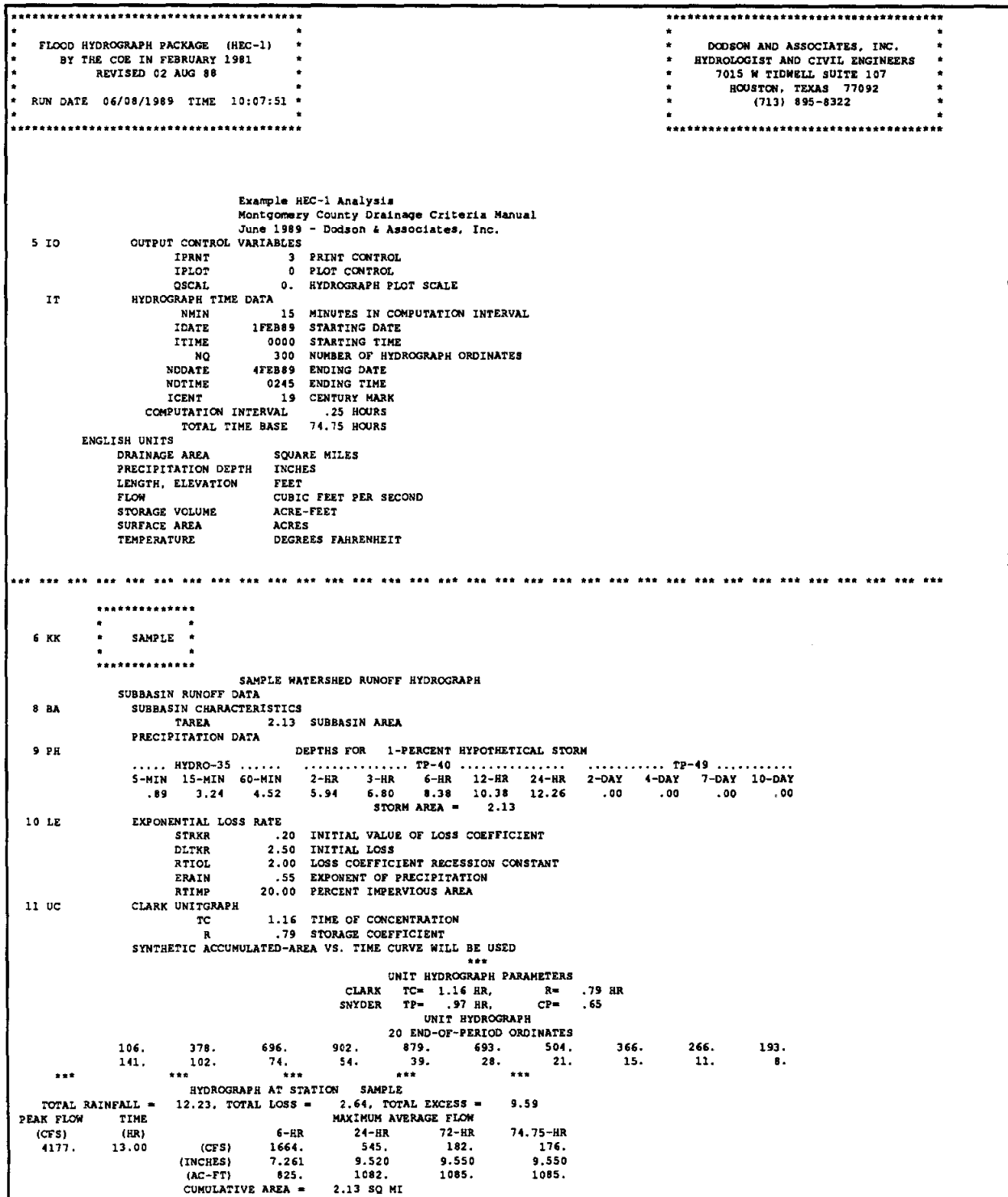

FIGURE 2.16B Example Watershed HEC-1 Output - Results

RUNOFF SUMMARY									
FLOW IN CUBIC FEET PER SECOND									
TIME IN HOURS, AREA IN SQUARE MILES									
OPERATION	STATION	PEAK	TIME OF	AVERAGE FLOW FOR MAXIMUM PERIOD			BASIN	MAXIMUM	TIME OF
HYDROGRAPH AT	SAMPLE	FLOW	PEAK	6-HOUR	24-HOUR	72-HOUR	AREA	STAGE	MAX STAGE
		4177.	13.00	1664.	545.	182.	2.13		

*** NORMAL END OF HEC-1 ***

FIGURE 2.16C Example Watershed HEC-1 Output - Runoff Summary

SECTION 3 OPEN CHANNELS

This section summarizes the practical considerations, technical principles, and criteria necessary for proper design of open channels. The analysis of open channel flow also aids in determining other flow-related concerns, such as culvert tailwater depths, time of concentration calculations (travel times), and flood elevations.

In a major drainage system, open channels offer significant advantages over closed conduits in regard to cost, flow capacity, flood storage, recreation, and aesthetics. However, open channels require considerable right-of-way and maintenance. Careful consideration must be given in the design process to insure that disadvantages are minimized and benefits are maximized. When a design approach not covered in this manual is to be used, it should be reviewed and discussed with the Montgomery County Drainage Administrator prior to commencing significant portions of the design effort.

3.1 OPEN CHANNEL HYDRAULICS

Open-channel flow may be classified into a number of different types. Flow in an open channel is said to be **steady** when the depth of flow does not change with time. The flow is termed **unsteady** if the flow depth does change with time. Open-channel flow is said to be **uniform** if the depth of flow is the same at all points along the channel. **Non-uniform** flow occurs when the depth fluctuates from point to point along the channel.

Steady uniform flow is the type of flow assumed for most open-channel hydraulics problems.

3.1.1 Critical Depth

The **celerity** of small gravity waves in a shallow channel is given by the term \sqrt{gy} where y is the depth and g is the gravitational constant. When the velocity of flow in a channel is equivalent to the velocity of a gravity wave, **critical flow at critical depth** exists. Flow at or near critical depth is characterized by instability and should be avoided in channel design except at specific flow transition points such as weirs and sluice gates. Near critical flow, small changes in hydraulic conditions will cause exaggerated changes in flow depth and velocity.

From open channel hydraulics theory it is given that **specific energy** ($E = y + V^2/2g$) is at a minimum when the depth is critical. By differentiating the expression for specific energy and further manipulating the resulting equation, the depth (y) becomes critical depth (y_c) and the following expression is obtained for application to a trapezoidal channel:

$$\frac{Q}{\sqrt{g}} = \frac{(by_c + z(y_c)^2)^{1.5}}{\sqrt{b + 2zy_c}} \quad \text{Equation 3.1}$$

in which:

b = channel bottom width (ft)

g = acceleration of gravity (32.2 ft/sec²)

y_c = critical depth (ft)

Q = discharge (cfs)

z = channel side slope where z equals the horizontal displacement for one unit of vertical displacement.

Thus, if Q , z , and b are known, the critical depth can be determined by solving Equation 3.1 to find y_c by trial.

3.1.2 Sub-critical or Super-critical Flow

When the velocity of flow in a channel exceeds the velocity at critical depth, the flow is **super-critical**. When it is less than this value, the flow is **sub-critical**. Super-critical flow is generally characterized by high velocities and shallow depths, while sub-critical flow is characterized by slower velocities and greater depths. The most important distinction between these two states of flow is that the effect of a disturbance in the channel, such as a bridge constriction, cannot be propagated upstream in super-critical flow as it can in sub-critical flow. Therefore, sub-critical flow is controlled by downstream channel conditions while super-critical flow is controlled by upstream channel conditions.

3.1.3 The Manning Equation

The Manning equation is an empirical relationship which relates friction slope, flow depth, channel roughness, and channel cross-sectional shape to flow rate. The **friction slope** is a measure of the rate at which energy is being lost due to channel resistance. When the channel slope and the friction slope are equal ($S_f = S_o$) the flow is uniform and the Manning equation may be used to determine the depth for uniform flow, commonly known as the **normal depth**.

The Manning equation is as follows:

$$V = \left(\frac{1.49}{n} \right) R^{2/3} \sqrt{S_f} \quad \text{Equation 3.2}$$

or

$$Q = \left(\frac{1.49}{n} \right) A R^{2/3} \sqrt{S_f} \quad \text{Equation 3.3}$$

in which:

Q = total discharge (cfs)

V = velocity of flow (ft/sec)

n = Manning coefficient of roughness

A = cross-sectional area of the flow (ft²)

R = hydraulic radius of the channel (ft) (flow area/wetted perimeter)

S_f = friction slope, the rate at which energy is lost due to channel resistance

Normal depth may be determined by using Equation 3.3. The area (A) and the hydraulic radius (R) are written in terms of the depth (y_o). Knowing the discharge (Q), Manning "n" value, and the channel slope (S_o), Equation 3.3 can be solved by trial to find normal depth (y_o). Exhibit 1 in Appendix A of this manual provides a nomograph for the solution of Equation 3.3 for trapezoidal channels.

3.1.4 Manning "n" Values

Manning "n" value is an experimentally derived constant which represents the effect of channel roughness in the Manning equation. Considerable care must be given to the selection of an appropriate "n" value for a given channel due to its significant effect on the results of the Manning equation. Tables 3.1 through 3.3 provide a listing of "n" values for various channel conditions.

TABLE 3.1 Manning Roughness Coefficient for Lined or Built-Up Channels

Type of Channel and Description	Minimum	Normal	Maximum
Metal			
Unpainted Smooth steel surface	0.011	0.012	0.014
Painted smooth steel surface	0.012	0.013	0.017
Corrugated metal	0.021	0.025	0.030
Cement			
Neat, surface	0.010	0.011	0.013
Mortar	0.011	0.013	0.015
Wood			
Planed, untreated	0.010	0.012	0.014
Planed, creosoted	0.011	0.012	0.015
Unplaned	0.011	0.013	0.015
Wood plank with battens	0.012	0.015	0.018
lined with roofing paper	0.010	0.014	0.017
Concrete			
Trowel finish	0.011	0.013	0.015
Float finish	0.013	0.015	0.016
Finished, with gravel on bottom	0.015	0.017	0.020
Unfinished	0.014	0.017	0.020
Gunite concrete, good section	0.016	0.019	0.023
Gunite concrete, wavy section	0.018	0.022	0.025
Concrete on good excavated rock	0.017	0.020	—
Concrete on irregular excavated rock	0.022	0.027	—
Concrete bottom float			
finished with sides of dressed stone in mortar	0.015	0.017	0.020
finished with sides of random stone in mortar	0.017	0.020	0.024
finished with sides of cement rubble masonry, plastered	0.016	0.020	0.024
finished with sides of cement rubble masonry	0.020	0.025	0.030
finished with sides of dry rubble or rip-rap	0.020	0.030	0.035
Gravel bottom			
sides of Formed concrete	0.017	0.020	0.025
sides of Random stone in mortar	0.020	0.023	0.026
sides of Dry rubble or rip-rap	0.023	0.033	0.036
Brick			
Glazed	0.011	0.013	0.015
in cement mortar	0.012	0.015	0.018
Rubble Masonry			
Cemented	0.017	0.025	0.030
Dry	0.023	0.032	0.035
Dressed ashlar	0.013	0.015	0.017
Asphalt			
Smooth	0.013	0.013	—
Rough	0.016	0.016	—
Vegetated lining	0.030	—	0.500

Source: [Chow, 1959]

TABLE 3.2 Manning Roughness Coefficient for Excavated or Dredged Channels

Type of Channel and Description	Minimum	Normal	Maximum
Earth, straight and uniform			
Clean, recently completed	0.016	0.018	0.020
Clean, after weathering	0.019	0.022	0.025
Gravel, uniform section, clean	0.022	0.025	0.030
With short grass, few weeds	0.022	0.027	0.033
Earth, winding and sluggish			
No vegetation	0.023	0.025	0.030
Grass, some weeds	0.025	0.030	0.033
Dense weeds or aquatic plants in deep channels	0.030	0.035	0.040
Earth bottom and rubble sides	0.028	0.030	0.035
Stony bottom and weedy banks	0.025	0.035	0.040
Cobble bottom and clean sides	0.030	0.040	0.050
Dragline-excavated or dredged			
No vegetation	0.025	0.028	0.033
Light brush or banks	0.035	0.050	0.060
Rock cuts			
Smooth and uniform	0.025	0.035	0.040
Jagged and irregular	0.035	0.040	0.050
Channels not maintained, weeds and brush uncut			
Dense weeds, high as flow depth	0.050	0.080	0.112
Clean bottom, brush on sides	0.040	0.050	0.080
Same, highest stage of flow	0.045	0.070	0.110
Dense brush, high stage	0.080	0.100	0.140

Source: [Chow, 1959]

TABLE 3.3 Manning Roughness Coefficient for Minor Natural Streams

Type of Channel and Description	Minimum	Normal	Maximum
a. Streams on plain			
1. Clean, straight, full stage, no rifts or deep pools	0.025	0.030	0.033
2. Same as above, but some stones and weeds	0.030	0.035	0.040
3. Clean, winding, some pools and shoals	0.033	0.040	0.045
4. Same as above, but some weeds and stones	0.035	0.045	0.050
5. Same as above, lower stages, more ineffective slopes and sections	0.040	0.048	0.055
6. Same as 4, but more stones	0.045	0.050	0.060
7. Sluggish reaches, weedy, deep pools	0.050	0.070	0.080
8. Very weedy reaches, deep pools, or floodways with heavy stand of timber and underbrush	0.075	0.100	0.150
b. Mountain streams, no vegetation in channel, banks usually steep, trees and brush along banks submerged at high stages			
1. Bottom: gravels, cobbles, and few boulders	0.030	0.040	0.050
2. Bottom: cobbles with large boulders	0.040	0.050	0.070

Source: [Chow, 1959] Note: A "minor stream" is one which has a top width of less than 100 feet at flood stage.

TABLE 3.4 Manning Roughness Coefficient for Major Natural Streams

Type of Channel and Description	Minimum	Normal	Maximum
Regular section with no boulders or brush	0.025	—	0.060
Irregular and rough section	0.035	—	0.100

Source: [Chow, 1959] Note: A major stream is one with a top width of more than 100 feet at flood stage. The n value is less than that for minor streams of similar description because banks offer less effective resistance.

TABLE 3.5 Manning Roughness Coefficient for Flood Plains

Type of Channel and Description	Minimum	Normal	Maximum
Pasture, no brush			
Short grass	0.025	0.030	0.035
High grass	0.030	0.035	0.050
Cultivated areas			
No crop	0.020	0.030	0.040
Mature row crops	0.025	0.035	0.045
Mature field crops	0.030	0.040	0.050
Brush			
Scattered brush, heavy weeds	0.035	0.050	0.070
Light brush and trees, in winter	0.035	0.050	0.060
Light brush and trees, in summer	0.040	0.060	0.080
Medium to dense brush, in winter	0.045	0.070	0.110
Medium to dense brush, in summer	0.070	0.100	0.160
Trees			
Dense willows, summer, straight	0.110	0.150	0.200
Cleared land with tree stumps, no sprouts	0.030	0.040	0.050
Same as above, but with heavy growth of sprouts	0.050	0.060	0.080
Heavy stand of timber, a few down trees, little undergrowth, flood stage below branches	0.080	0.100	0.120
Same as above, but with flood stage reaching branches	0.100	0.120	0.160

Source: [Chow, 1959]

TABLE 3.6 Parameters Used in Computing Manning Roughness Coefficient

Parameter	Accounts for	Representative Values
n_0	Channel Material	0.020 for Earth 0.025 for Rock Cut 0.024 for Fine Gravel 0.028 for Coarse Gravel
n_1	Degree of Irregularity	0.000 for Smooth 0.005 for Minor Irregularities 0.010 for Moderate Irregularities 0.010 for Severe Irregularities
n_2	Variation of Channel Cross-Section	0.000 for Gradual Variations 0.005 for Alternating Occasionally 0.010 to 0.015 for Alternating Frequently
n_3	Relative Effect of Obstructions	0.000 for Negligible Obstructions 0.010 to 0.015 for Minor Obstructions 0.020 to 0.030 for Appreciable Obstructions 0.040 to 0.060 for Severe Obstructions.
n_4	Vegetation	0.005 to 0.010 for Low Vegetation 0.010 to 0.025 for Medium Vegetation 0.025 to 0.050 for High Vegetation 0.050 to 0.100 for Very High Vegetation
m	Degree of Meandering	1.000 for Minor Meandering 1.150 for Appreciable Meandering 1.300 for Severe Meandering

Source: [Chow, 1959]

Equation 3.4 presents a method to compute a composite roughness coefficient based on various channel characteristics [Chow, 1959].

$$n = (n_0 + n_1 + n_2 + n_3 + n_4)m \quad \text{Equation 3.4}$$

in which:

n = Computed Value of Manning Roughness Coefficient

Table 3.6 defines and lists representative values for the other terms in the equation.

3.2 OPEN CHANNEL DESIGN

The proper hydraulic design of a channel is of primary importance in insuring that flooding, sedimentation and erosion problems do not occur. The following general criteria should be utilized in the design of open channels.

3.2.1 Design Frequencies for Open Channel Design

All open channels in South Montgomery County shall be designed to contain the runoff from the 100-year frequency 24-hour duration storm within the right-of-way. In addition, the channel must be designed to have sufficient freeboard to provide for adequate drainage of lateral storm sewers during the 25-year storm.

In those cases where channel modifications are necessary to control increased flow from proposed development, proposed water surface profiles are restricted such that the 100-year flood profile under existing conditions shall not be increased. If the capacity of the existing channel downstream of the project is less than the 100-year design discharge, consideration shall be given for more frequent events to ensure that the severity and frequency of downstream flooding are not increased.

3.2.2 Required Documentation for Open Channel Designs

The following information must be submitted to the Montgomery County Drainage Administrator for the design of open channels:

- 1) **Vicinity Map:** A vicinity map of the site and subject reach. The **subject reach** is the stretch of channel necessary for any altered flow profile to match the upstream and downstream existing profiles.
- 2) **Site Map:** A detailed map of the area and subject reach with all pertinent physiographic information.
- 3) **Watershed Map:** A watershed map showing existing and proposed drainage area boundaries along with all sub-area delineations and all areas of existing or proposed development.
- 4) **Discharge Calculations:** Discharge calculations specifying the methodology and key assumptions used, along with computed discharges at key locations.
- 5) **Hydraulic Calculations:** Hydraulic calculations specifying the methodology used. All assumptions and values of design parameters must be clearly stated.
- 6) **Plotted Stream Profile:** A stream profile of the subject reach which includes the following:
 - a) All pertinent water surface profiles. This will minimally include the 25-year and 100-year frequency floods for both existing and proposed conditions.
 - b) All existing and proposed bridge, culvert and pipeline crossings.
 - c) The locations of all tributary and drainage confluences.
 - d) The locations of all hydraulic structures (e.g. dams, weirs, drop structures, etc.).
- 7) **Right-of-way Map:** A right-of-way map illustrating all existing and proposed channel rights-of-way.
- 8) **Benchmark Information:** A description of the benchmark used in obtaining field survey data, including the location, elevation, datum, and year of adjustment.
- 9) **Plotted Cross-Sections:** Typical existing and proposed cross-sections.
- 10) **Soils Report:** A soils report which addresses erosion and slope stability.

3.2.3 Channel Flow Velocities

Excessive flow velocities in open channels can cause erosion and destabilize side slopes, and may pose a threat to safety. Velocities which are too low may allow the deposition of sediment and subsequent channel clogging. Table 3.7 provides desirable average and maximum allowable velocities based on 25-year flow rates.

TABLE 3.7 Allowable 25-Year Flow Velocities for Channel Design

Channel Description	Average Velocity (Feet Per Second)	Maximum Velocity (Feet Per Second)
Grass Lined: Predominantly Clay Soil	3.0	5.0
Grass Lined: Predominantly Sand Soil	2.0	4.0
Rip-rap Lined	5.0	8.0
Concrete Lined	6.0	10.0

Source: [HCFCD, 1984]

3.2.4 Channel Flow-Line Slope

Slope of the channel flow-line (invert) is generally governed by topography and the energy head required for flow. Since flow-line slope directly affects channel velocities, channels should have sufficient grade to prevent significant siltation. However, slopes should not be so large as to create erosion problems. In Montgomery County, the minimum recommended channel flow-line slope is 0.05 percent. The use of flatter slopes must be approved by the Montgomery County Drainage Administrator. The maximum channel invert slope will be limited by the maximum flow velocities given in Table 3.7. Appropriate channel drop structures may be used to limit channel invert slopes in steep areas.

3.2.5 Channel Side Slope

In grass-lined channels, the normal maximum side slope will be 3 horizontal to 1 vertical (3:1), which is the practical limit for mowing equipment. In some areas, local soil conditions may dictate the use of side slopes flatter than 3:1 to ensure slope stability.

3.2.6 Channel Bottom Width

In grass-lined channels, the minimum channel bottom width shall be six (6) feet. In concrete-lined channels, the minimum bottom width shall be eight (8) feet.

3.2.7 Manning Roughness Coefficient

The values of the Manning roughness coefficient listed in Table 3.8 should be used in the design of channel improvements. Alternative values should be discussed with the Montgomery County Drainage Administrator.

TABLE 3.8 Manning Roughness Coefficient for Improved Channels

Channel Cover	"n" value
Grass-lined	0.040
Concrete-lined	0.015
Rip-rap-lined	0.040

3.2.8 Channel Transitions

Expansions and contractions should be designed to create minimal flow disturbance and thus minimal energy loss. Transition angles should be less than 12 degrees, or about five units parallel to the channel center-line to 1 unit perpendicular to the invert (5:1). When connecting rectangular to trapezoidal channels, a warped or wedge-type transition is recommended.

3.2.9 Channel Confluences

The angle of intersection between tributary and main channels should be between 15 degrees and 45 degrees. Angles in excess of 45 degrees are permissible but are discouraged. Angles in excess of 90 degrees are not permitted.

3.2.10 Channel Bends

In general, center-line curves should be as gradual as possible and not have a radius of less than three times the design top width. A smaller radius may be used where erosion protection is provided, but the radius may not be less than 100 feet. The maximum deflection angle for any curve in a man-made channel should be 90 degrees.

3.2.11 Channel Maintenance

Due consideration must be given to the maintainability of man-made channels. Channel designs which incorporate measures that may hinder the efforts of maintenance personnel should be avoided. Sufficient right-of-way should be provided to allow easy access by maintenance equipment.

3.2.12 Channel Erosion Control

Erosion protection is necessary to insure that channels maintain their capacity and stability and to avoid excessive transport and deposition of eroded material. The three main parameters which affect erosion are vegetation, soil type, and the magnitude of flow velocities and turbulence. In general, silty and sandy soils are the most vulnerable to erosion.

The necessity for erosion protection should be anticipated in the following settings:

- 1) **Channel Bends:** Areas of channel curvature, especially where the radius of the curve is less than three times the design flow top width.
- 2) **Bridges:** Around bridges where channel transitions create increased flow velocities.
- 3) **Steep Sections:** When the channel invert is steep enough to cause excessive flow velocities.
- 4) **Sheet Flow:** Along grassed channel side slopes where significant sheet flow enters the channel laterally.
- 5) **Channel Confluences:** Where tributaries enter a channel.
- 6) **Erosion-Prone Soils:** In areas where the soil is particularly prone to erosion.

Sound engineering judgement and experience should be used in locating areas which require erosion protection. It is often prudent to analyze potential erosion sites following a significant storm event to pinpoint areas of concern. SECTION 6 of this manual contains detailed information on requirements for erosion control in open channels.

3.2.13 Minimum Requirements for Grass-Lined Channels

Figure 3.1 illustrates a cross-section of a typical grass-lined channel. The following are minimum requirements to be used in the design of all grass-lined channels:

- 1) **Channel Side Slopes:** Maximum (steepest) side slopes shall be 3:1. Slopes flatter than 3:1 may be necessary in some areas due to local soil conditions.

- 2) **Channel Bottom Width:** Minimum bottom width is six (6) feet.
- 3) **Channel Right-of-Way:** A minimum maintenance berm is required on both sides of the channel. The width of the berms shall be between 15 and 30 feet depending upon channel size. For channel top widths of 30 feet or less, 15-foot berms are acceptable; for top widths between 30 and 60 feet, 20-foot berms are required; and for top widths of 60 feet or greater, 30-foot berms are required along both sides of the channel. The elevation of the top of the berm should be at natural ground along the channel reach. See Table 3.10.

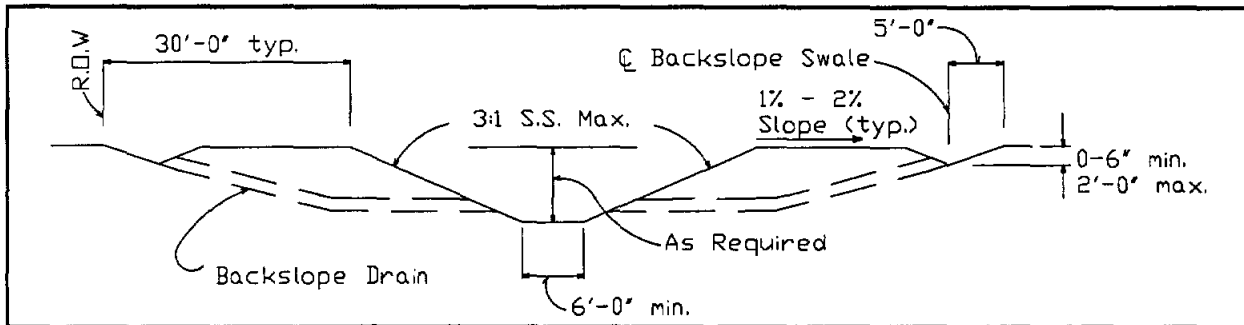

FIGURE 3.1 Typical Section - Grass-Lined Trapezoidal Channel

- 4) **Channel Backslope Drains:** Backslope interceptor structures are necessary at a maximum spacing of 800 feet to prevent sheet flow over the ditch side slopes.
- 5) **Channel Erosion Control:** Channel slopes must be revegetated immediately after construction to minimize erosion.
- 6) **Ditch Interceptor Structures:** Flow from roadside ditches must be conveyed to the channel through a roadside ditch interceptor structure and pipe. See the ditch interceptor structure and pipe detail on Figure 6.3 of this manual.
- 7) **Geotechnical Report:** Unless waived by the Montgomery County Drainage Administrator, a geotechnical investigation and report must be provided.

3.2.14 Minimum Requirements for Concrete-Lined Trapezoidal Channels

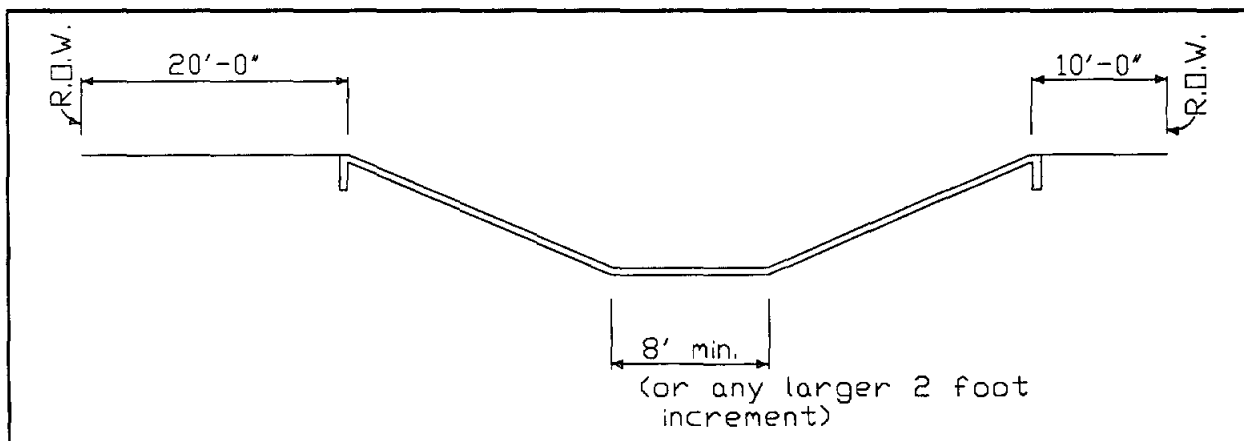

FIGURE 3.2 Typical Section - Concrete-Lined Trapezoidal Channel

Figure 3.2 illustrates a cross-section of a typical concrete-lined channel. All partially or fully concrete-lined trapezoidal channels must meet or exceed the following minimum design requirements:

- 1) **Class A Concrete:** All concrete shall be Class A concrete unless noted otherwise.

- 2) **Channel Bottom Width:** Fully lined cross-sections shall have a minimum bottom width of eight (8) feet.
- 3) **Channel Right-of-Way:** A minimum maintenance berm is required on both sides of the channel. The width of the berm will be 20 feet on one side of the channel and 10 feet on the other side. The elevation of the top of the berm should be at natural ground along the channel reach. See Table 3.10.
- 4) **Reinforcement:** Concrete slope protection shall have the minimum thickness and reinforcement indicated in Table 3.9. Cast-in-place concrete side slopes should not be steeper than 1.5:1.

TABLE 3.9 Minimum Thickness and Reinforcement for Concrete Slope Paving

Channel Side Slopes (H:V)	Minimum Concrete Thickness	Minimum Reinforcement
3:1	4 inches	6 x 6 x W2.9 x W2.9 welded wire fabric
2:1	5 inches	6 x 6 x W4.0 x W4.0 welded wire fabric
1.5:1	6 inches	4 x 4 x W4.0 x W4.0 reinforcement

Note: Reinforcement equivalent to the stated minimum will be acceptable.

- 5) **Toe Walls:** All slope paving shall include a minimum 18-inch toe wall at the top and sides and a 24-inch toe wall across or along the channel bottom for clay soils. In sandy soils, a 36-inch toe wall is required across the channel bottom.
- 6) **Backslope Drains:** In instances where the channel is fully lined, backslope drainage structures may not be required. Partially lined channels will require backslope drainage structures.
- 7) **Weep Holes:** Weep holes shall be used to relieve hydrostatic head behind lined channel sections. The specific type, spacing and construction method for the weep holes will be based on the recommendations of the geotechnical report.
- 8) **Seal Slab:** Where construction is to take place under muddy conditions or where standing water is present, a seal slab of Class C concrete shall be placed in the channel bottom prior to the placement of concrete slope paving.
- 9) **Control Joints:** Control joints shall be provided at a spacing of approximately twenty-five feet on center. The use of a sealing agent shall be utilized to prevent moisture infiltration.

3.2.15 Minimum Requirements for Rectangular Concrete Pilot Channels

Figure 3.3 illustrates a cross-section of a typical concrete-lined channel with a rectangular low flow section. For purposes of illustration only, the channel in Figure 3.3 has one concrete-lined slope and one grass-lined slope. Normally, both slopes would be either concrete-lined or grass-lined. In areas where it is necessary to use a vertical-walled rectangular section, the following minimum requirements are to be addressed:

- 1) **Class A Concrete:** All concrete shall be Class A concrete unless noted otherwise.
- 2) **Reinforcement:** The structural steel design should be based on ASTM A-615, Grade 60 steel.
- 3) **Channel Bottom Width:** Minimum bottom width shall be eight (8) feet.
- 4) **Channel Bottom Slope:** For bottom widths twelve (12) feet or greater, the channel bottom shall be graded toward the channel center line at a slope of 1/2 inch per foot.
- 5) **Vertical Wall Height:** Minimum height of vertical walls shall be four (4) feet. Heights above this shall be in two (2) foot increments. Exceptions shall be on a case by case basis.
- 6) **Escape Stairways:** Escape stairways shall be located at the upstream side of all street crossings, but not to exceed 1,400 feet intervals.

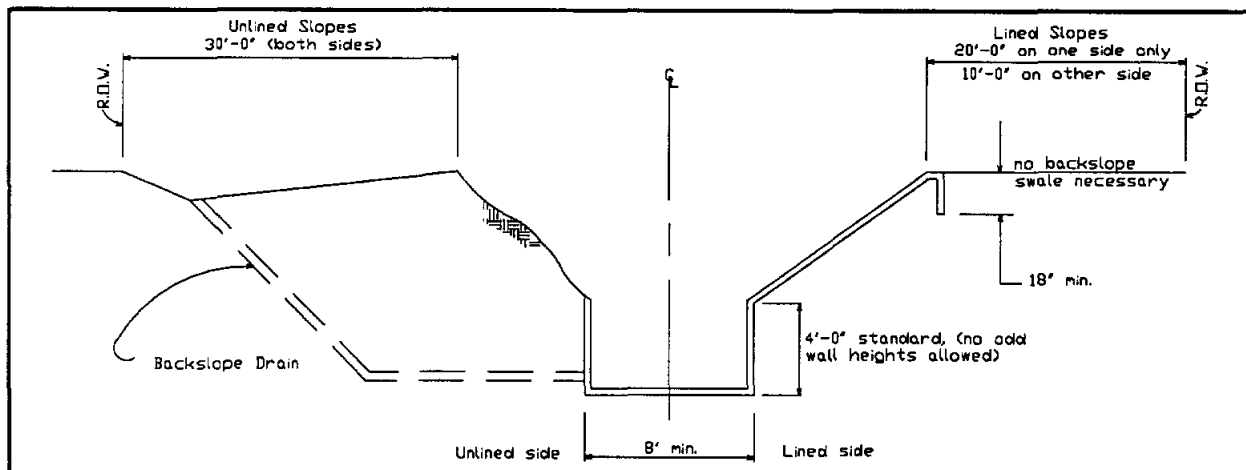

FIGURE 3.3 Typical Section - Concrete-Lined Low Flow Channel

- 7) **Future Slope Paving:** For rectangular concrete pilot channels with grass side slopes, the top of the vertical wall should be constructed to allow for future placement of concrete slope paving.
- 8) **Weep Holes:** Weep holes should be used to relieve hydrostatic pressures. The specific type, spacing and construction method for the weep holes will be based on the recommendations of the geotechnical report.
- 9) **Seal Slab:** Where construction is to take place under muddy conditions or where standing water is present, a seal slab of Class C concrete should be placed in the channel bottom prior to the placement of concrete slope paving.

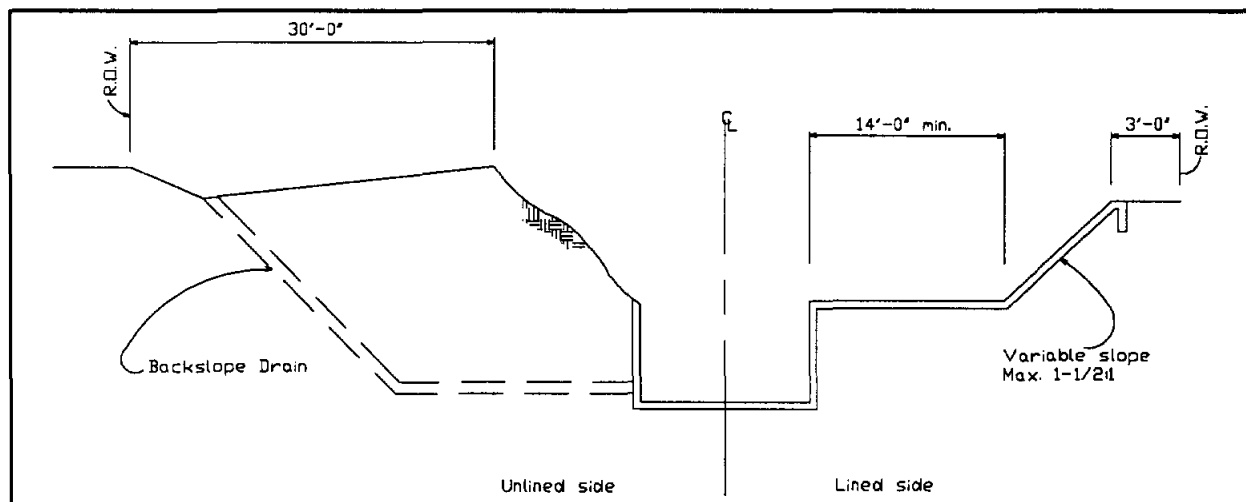

FIGURE 3.4 Concrete-Lined Low Flow Channel with Maintenance Shelf

- 10) **Maintenance Shelves:** Concrete pilot channels may be used in combination with slope paving or a maintenance shelf, as illustrated in Figure 3.4. Horizontal paving sections should be analyzed as one-way paving capable of supporting maintenance equipment having a concentrated wheel load of up to 1,350 lbs.
- 11) **Control Joints:** Control joints shall be provided at a spacing of approximately twenty-five feet on center. The use of a sealing agent shall be utilized to prevent moisture infiltration.

- 12) **Structural Calculations:** Structural calculations shall be provided for all concrete pilot channels.

3.3 CHANNEL RIGHT-OF-WAY REQUIREMENTS

The amount of right-of-way required for open channels shall be based on full development of the watershed and is dependent on channel top width and channel type (grass-lined or concrete-lined) as required to accommodate the discharge resulting from the 100-year, 24-hour rainfall event. Adequate area must be set aside for both the channel itself and the adjacent berm required for channel maintenance. Minimum right-of-way requirements for Montgomery County include the channel top width from bank to bank plus the maintenance berm areas on both sides and shall be dedicated at the time of platting of the adjacent property. However, if additional right-of-way is required to serve upstream development prior to downstream platting, sufficient right-of-way must be dedicated to accommodate the improved channel and provide adequate maintenance berms. See Table 3.10.

TABLE 3.10 Channel Right-of-Way Requirements

Channel Type	Top Width	Maintenance Berm Width
Grass-Lined	Less than 30 feet	15 feet on both sides
Grass-Lined	30 feet to 60 feet	20 feet on both sides
Grass-Lined	60 feet or greater	30 feet on both sides
Concrete-Lined	All	10 feet on one side, 20 feet on one side

Note: If concrete lining does not extend all the way up to the top of bank, the maintenance berm requirements for grass-lined channels apply.

3.4 CHANNEL WATER SURFACE PROFILE COMPUTATIONS

Several methods exist which can be used to compute water-surface profiles in open channels. The methodology selected depends on the complexity of the hydraulic design and the level of accuracy desired.

For an existing or proposed channel with flow confined to uniform cross-sections, a hand-calculated normal depth or direct step computation is sufficient. Manning's equation should be used for computing normal depths. For evaluating non-uniform channels for existing conditions or designing a proposed channel with flow in the overbanks, the standard step method is recommended.

Two computer programs which make use of the standard step method are available: the HEC-2 program developed by the U.S. Army Corps of Engineers and the WSP-2 program developed by the Soil Conservation Service. The use of HEC-2 is encouraged because it is widely accepted and it offers flexibility in designing channels. The program also offers special enhancements which allow the determination of head losses at bridges and other structures.

If an alternative design methodology, equation, or procedure not presented in this manual is applied to a specific problem, approval should be obtained from the Montgomery County Drainage Administrator prior to initiation of the analysis.

3.4.1 Orientation of Channel Cross-Sections

Channel cross-sections should be oriented from left to right, with these directions determined while looking downstream. Each segment of the cross-section should generally be aligned so that it is perpendicular to the direction of flow across that segment. The end points of each cross-section should be higher than the computed energy grade line elevation.

3.4.2 Channel Stationing

Channel stationing should begin with 0+00 at the downstream end of the channel (usually at the flow-line of the stream into which the channel being surveyed empties) and increase in the upstream direction. Stationing should be measured along the flow-line of the channel. Channel cross-sections should be identified by the channel station at which the cross-section intersects the channel center-line.

3.4.3 Channel Cross-Section Spacing

The spacing of channel cross-sections is very important, as it can have a significant impact on computations of water surface elevations. In general, the maximum distance between cross-sections should be 500 feet for unimproved channels and 2,000 feet for improved, regular channels. These distances should be measured along the center-line of the stream. Additional cross-sections should be inserted wherever discontinuities or irregularities are encountered. These include transitions, curves and bends, drop structures, bridges, and culvert crossings.

3.4.4 Number of Data Points

A minimum of five (5) points is usually required for the channel portion of a surveyed cross-section. This includes one point at the top of each channel bank, one point at the toe of each side slope, and one point at the channel flow-line. Additional points may be required when discontinuities in channel cross-sections are encountered. Conversely, there are some situations in which fewer points are required. The number of cross-section points required for overbank areas is dependent on the width of the cross-section and on the character of the terrain in the overbank. As a general rule, enough points should be obtained to give a true representation of the channel shape and overbank terrain, and to define any breaks or discontinuities in topography which may exist.

3.4.5 Starting Water-Surface Elevation

The starting elevation for water surface profile computations may be specified in one of three ways: (1) as critical depth, (2) as a known elevation, and (3) by the slope-area method. Starting at critical depth is appropriate only at locations where critical or near-critical flow conditions are known to exist for the range of discharges being computed, e.g., a drop structure or weir.

When an accurate rating curve is available, the appropriate starting elevation can be specified as a known value. Alternatively, the starting elevation may be specified as the water surface elevation in the receiving stream. Care must be exercised when using the latter approach, however. It is important to make sure that the use of the water surface elevation in a receiving stream does not result in a coincident storm frequency greater than the design storm frequency for the stream being analyzed. For instance, the use of 100-year flow rates in the analysis of a tributary stream along with a starting water surface elevation equal to the 100-year water surface elevation in the receiving stream may result in a coincident storm return period of greater than 100 years.

If critical flow conditions do not exist, and the starting water surface elevation for the stream cannot be determined from a rating curve or other source of information, the slope-area method must be used. For beginning backwater computations by this method, the slope of the energy grade line is specified. As a first trial, the starting slope may be set equal to the physical slope of the channel. A trial and error approach should be used to refine the estimate of the slope of the energy grade line until the specified slope at the first channel cross-section is consistent with the computed energy slope at several subsequent cross-sections.

3.4.6 Channel Friction Losses

Manning's equation should be used to determine energy losses due to channel friction and resistance. A discussion of Manning's equation is presented in 3.1.3 The Manning Equation.

3.4.7 Expansions and Contractions

Losses at transitions are generally expressed in terms of the absolute change in velocity head between channel cross-sections downstream and upstream of the transition. The head loss is given by equation 3.5.

$$h_1 = C \frac{(V_2^2 - V_1^2)}{2g} \quad \text{Equation 3.5}$$

in which:

h_1 = head loss across the transition (ft)

C = empirical expansion or contraction coefficient

V_2, V_1 = average channel velocity (fps) of the downstream and upstream sections, respectively

g = acceleration of gravity (32.2 ft/sec²).

Typical transition loss coefficients for sub-critical flow are shown in Table 3.11.

TABLE 3.11 Typical Transition Loss Coefficients for Sub-Critical Flow

Type of Transition	Contraction Coefficient	Expansion Coefficient
Gradual or warped	0.1	0.3
Bridge Sections, wedge, straight-lined	0.3	0.5
Abrupt or square-edged	0.6	0.8

Source: [HEC, 1982].

These transition loss coefficients are also adequate for general design with super-critical flow; however, the effects of standing waves and other considerations make exact determination of losses in super-critical flow difficult. Therefore, with important transitions, a more detailed analysis may be necessary.

3.4.8 Channel Bends

Head losses should be incorporated into the backwater computations for bends with a radius of curvature less than three times the channel top width. Energy loss due to curve resistance is computed using equation 3.6.

$$hL = C_f \frac{V^2}{2g} \quad \text{Equation 3.6}$$

in which:

hL = head loss (feet)

C_f = coefficient of resistance

V = average channel velocity (feet per second)

g = gravitational acceleration (32.2 ft/sec²).

Guidelines for selecting appropriate values of C_f are available [Chow, 1959].

The HEC-2 computer program does not incorporate a bend loss computation. If HEC-2 is used and bend losses are significant, the loss must be added at the appropriate point in the computation. Bends with a radius of curvature greater than three times the top width of the channel generally have insignificant losses and no computation is required.

3.4.9 Bridges and Culverts

There are numerous methods available to compute the energy losses associated with flow through bridges or culverts. Sources of energy loss in these structures include flow resistance, channel transitions, and direct obstructions to the flow such as piers. Each structure should be examined individually to determine the best approach. The bridge modeling routines found in HEC-2 are recommended for their versatility and flexibility. Brief descriptions of what they do and when they should be used are as follows:

HEC-2 Normal Bridge Method: The normal bridge method computes the water surface profile through the bridge in the same manner as in a natural river section, except that the flow area and wetted perimeter are modified. The normal bridge method should be used when friction losses are the predominate consideration. This includes long culverts under low flow conditions and cases where the bridge and abutments are small obstructions to the flow. Because the special bridge method requires a trapezoidal approximation of the bridge opening for low flow solutions, the normal bridge method can be used when the flow area cannot be reasonably approximated by a trapezoid. Also, when highly submerged weir flow occurs over a bridge, the normal bridge method is preferred.

HEC-2 Special Bridge Method: The special bridge method is capable of solving flow problems where losses are due primarily to factors other than friction. It uses a series of equations to compute energy losses depending on the existence of low flow, pressure flow, weir flow, or some combination of these at the bridge. Special care must be taken to ensure that the special bridge method is used properly and its results are reasonable. Whenever flow crosses critical depth in a structure, the special bridge method should be used.

The use of alternative means for computing bridge- and culvert-related losses is encouraged when the engineer is properly aware of how and why such a strategy is appropriate and its results are reasonable. One example of such an alternative method involves the use of the procedures described in Federal Highway Administration's (FHWA) *Hydraulics of Bridge Waterways* [Bradley, 1970]. Another is presented in the FHWA's *Hydraulic Design of Highway Culverts* [FHWA, 1985]. Caution must be exercised to insure that the losses calculated by alternative methods are properly used in the HEC-2 program. For example, the FHWA technique provides the increase in water surface elevation above the normal water surface elevation without the bridge. Therefore, it includes the effects of contraction and expansion losses and the loss caused by the structure, but it does not reflect the normal friction loss that would occur without the bridge.

More details on the design and analysis of culvert and bridge structures are presented in SECTION 4.

SECTION 4 CULVERTS AND BRIDGES

For small drainage areas, the most economical means of moving open channel flow beneath a road or railroad is generally with culverts. Discussion in this section will address procedures for determining the most cost effective culvert size and shape given a design discharge and allowable headwater elevation. The design procedures for the culverts referenced in this section pertain only to those in the main channels and not those in roadside ditches, which are covered in SECTION 5.

This section will also include a brief discussion of the hydraulic and hydrologic considerations pertinent to bridge design. This section considers all designs to be completed for ultimate development. Where appropriate, the actual construction of a crossing may be phased as development occurs. In this case, both the ultimate and the interim crossings must be shown on the construction plans. Calculations for each must be submitted for approval. The ultimate right-of-way is required even for an interim phase of construction.

4.1 CULVERTS

4.1.1 Design Storm Frequency

All culverts in Montgomery County shall be designed to handle the 100-year flood flow for fully developed conditions without causing upstream or downstream water surface profiles to exceed maximum levels as defined in SECTION 3.

4.1.2 Culvert Alignment

Culverts shall be aligned parallel to the longitudinal axis of the channel to insure maximum hydraulic efficiency and minimum erosion. In areas where a change in alignment is necessary, the change shall be accomplished upstream of the culvert crossing in the open channel. Appropriate erosion protection shall be provided.

4.1.3 Culvert Length

Culverts shall be designed to completely span the road or railroad right-of-way.

4.1.4 Culvert Headwalls and Endwalls

Headwalls and endwalls shall be utilized to control erosion and scour, to anchor the culvert against lateral pressures, and to insure bank stability. All headwalls shall be constructed of reinforced concrete and may be either straight and parallel to the channel, flared, or warped, with or without aprons, as required by site and hydraulic conditions. Protective guardrails should be included along culvert headwalls.

In general, the following conditions are favorable for the use of **parallel** headwalls and endwalls [City of Austin, undated]:

- 1) Approach velocities are less than 6 fps.
- 2) Backwater pools may be permitted.
- 3) Approach channel is undefined.
- 4) Ample right-of-way or easement is available.
- 5) Downstream channel protection is not required.

The wings of **flared** headwalls and endwalls should be located with respect to the direction of the approaching flow instead of the culvert axis. The following conditions are favorable for the use of a flared headwall and endwall:

- 1) Channel is well defined.
- 2) Approach velocities are greater than 6 fps.
- 3) Medium amounts of debris exist.

Warped headwalls are effective with drop-down aprons to accelerate flow through culvert, and are effective headwalls for transitioning flow from closed conduit flow to open channel flow. This type of headwall should be used only where the drainage structure is large and right-of-way or easement is limited. The following conditions are favorable for the use of a warped headwall and endwall:

- 1) Channel is well defined and concrete lined.
- 2) Approach velocities are greater than 8 fps.
- 3) Medium amounts of debris exist.

4.1.5 Minimum Culvert Sizes

The minimum pipe culvert diameter shall be 24 inches and the minimum box culvert dimensions shall be 2 feet by 2 feet. These restrictions are made to guard against flow obstruction. Sizes less than these shall be considered on a case by case basis.

4.1.6 Manning's "n" Values for Culverts

The minimum Manning's "n" value to be used in concrete culverts shall be 0.013. For corrugated metal, the "n" value shall be as follows:

TABLE 4.1 Manning Roughness Coefficient for Corrugated Metal Pipe

Corrugation (Span x Depth)	"n"
2-2/3" x 1/2"	0.024
3" x 1"	0.027
5" x 1"	0.027
6" x 2"	0.030

4.1.7 Erosion at Culverts

Culverts, because of their hydraulic characteristics, generally increase the velocity of flow over that found in the natural channel. For this reason, the tendency for erosion, especially at the outlet, must be addressed. In general, culvert discharge velocities in unprotected channels should not exceed allowable channel velocities as defined in Table 3.7. SECTION 6 contains information concerning erosion protection requirements for open channels.

4.1.8 Structural Requirements for Culverts

The following structural requirements, taken from *Criteria Manual for Design of Flood Control and Drainage Facilities in Harris County, Texas* [HCFCD, 1984], shall be met for culvert design in Montgomery County:

- 1) **Concrete Pipe Culverts:** All precast reinforced concrete pipe shall be ASTM C-76 (*minimum*).
- 2) **Box Culverts:** All precast reinforced concrete box culverts with more than two feet of earth cover shall be ASTM C789 -79. All precast reinforced concrete box culverts with less than two feet of cover shall be ASTM 850-79.
- 3) **Corrugated Metal Culverts:** All corrugated metal pipes shall be ASTM A-760.
- 4) **Loading:** ASSHTO HS20-44 loading should be used for all culverts.
- 5) **Guardrails:** Guardrails are suggested at all roadway culvert crossings. The approach ends of the guardrail shall be flared away from the roadway and properly anchored.

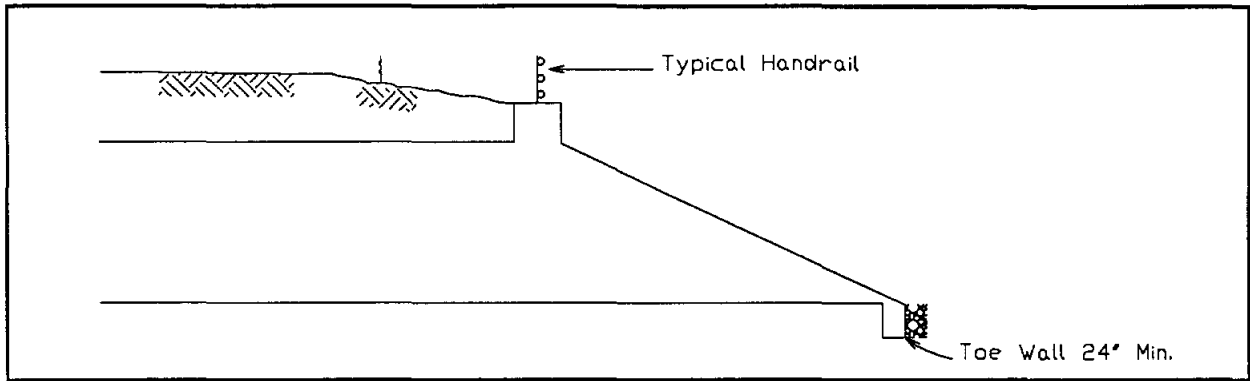

FIGURE 4.1 Profile of Typical Culvert

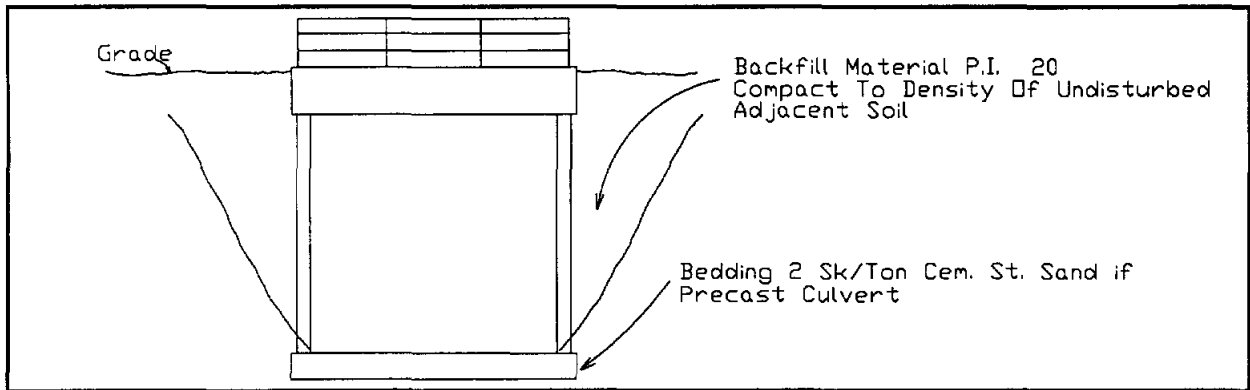

FIGURE 4.2 Section of Typical Culvert

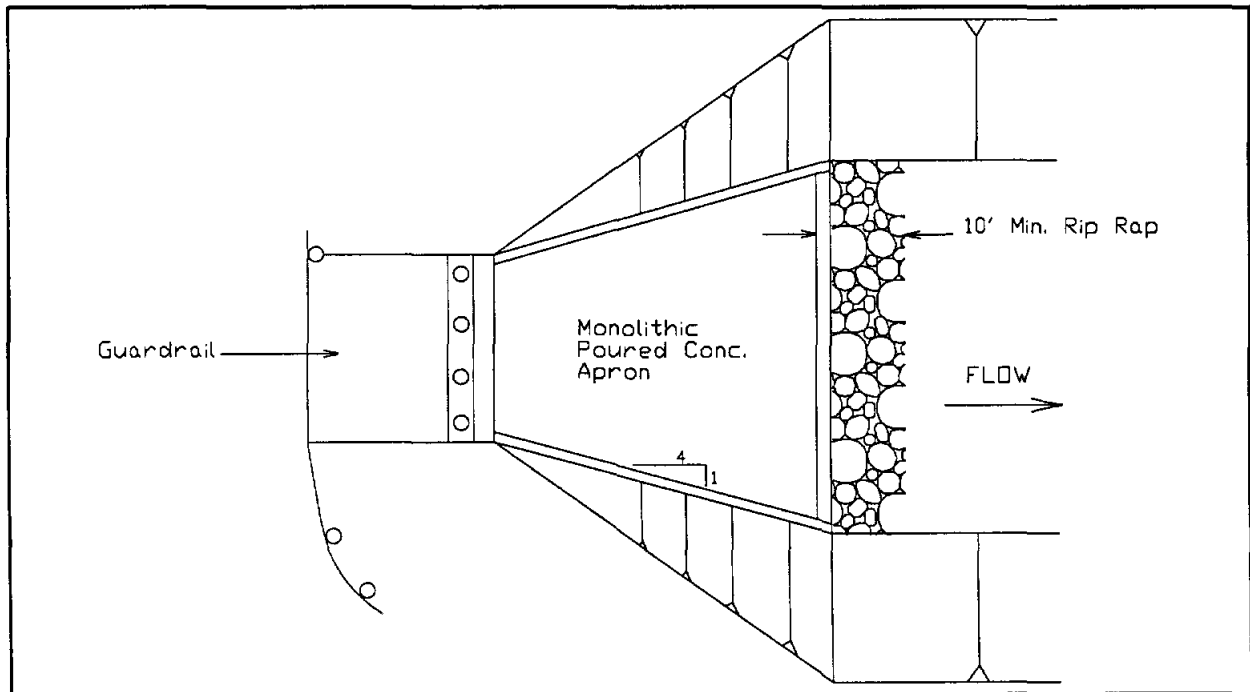

FIGURE 4.3 Typical Culvert Outlet

- 6) **Joint Sealant:** Joint sealing material for precast concrete culverts shall comply with the "AASHTO Designation M-198 74 I, Type B, Flexible Plastic Gasket (Bitumen)" specification.
- 7) **Backfill:** Two-sack-per-ton cement-stabilized sand shall be used for backfill around culverts.
- 8) **Bedding:** A 6-inch bedding of two-sack-per-ton cement-stabilized sand is required for all precast concrete box culverts.

4.1.9 Hydraulic Design of Culvert Installations

The hydraulic capacity of a culvert is said to be either inlet-controlled or outlet-controlled. **Inlet control** means that the discharge in the culvert is limited by the hydraulic and physical characteristics of the inlet alone. These include headwater depth, culvert barrel shape, barrel cross-sectional area, and the type of inlet edge. For inlet control, the barrel roughness, length, and slope are not factors in determining culvert capacity.

Under **outlet control**, the discharge capacity of the culvert is dependent on all of the hydraulic variables of the structure. These include headwater depth, tailwater depth as well as barrel shape, cross-sectional area, barrel roughness, slope, and length.

In all culvert design, **headwater**, or depth of ponding at the entrance to the culvert, is an important factor in culvert capacity. The headwater depth (*HW*) is the vertical distance from the invert at the culvert entrance to the energy grade line of the approaching flow. Due to low velocities in most entrance pools and the difficulty in determining velocity head in any flow, the energy line can often be assumed be the same as the water surface.

For culverts under outlet control, **tailwater depth** is an important factor in computing both headwater depth and the hydraulic capacity of the culvert. If flow in the channel downstream of the culvert is sub-critical, a computer-aided backwater analysis or calculation of normal depth is warranted to determine the tailwater elevation. If the downstream flow is super-critical, tailwater depth is not a factor in determining the culvert's hydraulic capacity.

4.1.9.1 Inlet-Controlled Flow

Under inlet control, the culvert entrance may or may not be submerged. However, in all cases inlet-controlled flow through the culvert barrel is free surface flow. When the culvert inlet is submerged, the most reliable means for determining discharge is with standard empirical relationships. Nomographs which plot headwater vs. discharge for various culvert sizes and shapes under inlet control have been developed on the basis of laboratory research with models and full scale prototypes. Exhibit 2 in Appendix A is an example of such a nomograph.

4.1.9.2 Outlet-Controlled Flow

Culverts with outlet control flow with the culvert barrel full or partially full for part or all of the barrel length. Both the headwater and tailwater may or may not submerge the culvert.

If the culvert is flowing full, the energy required to pass a given quantity of water is stored in the head (*H*). From energy considerations it can be shown that *H* is the difference between the hydraulic grade line at the outlet and the energy grade line at the inlet (expressed in feet).

When a given discharge passes through a culvert, stored energy, represented by the total head (*H*) is dissipated in three ways. A portion is lost to turbulence at the entrance (*H_e*); a portion is lost to frictional resistance in the culvert barrel (*H_f*); and a portion is lost as the kinetic energy of flow through the culvert is dissipated in the tailwater (*H_o*). From this, the following relationship is evident:

$$H = H_e + H_f + H_o \quad \text{Equation 4.1}$$

The entrance loss (H_e) is determined by multiplying the culvert velocity head by an entrance loss coefficient k_e . Table 4.2 through 4.4 list values for the entrance loss coefficient. In these tables, the entrances described as "End section conforming to fill slope" are the sections commonly available from manufacturers. From limited hydraulic tests they are equivalent in operation to a headwall in both inlet and outlet control. Some end sections, incorporating a closed taper in their design, have a superior hydraulic performance.

TABLE 4.2 Entrance Loss Coefficients for Concrete Pipe Culverts

Type of Structure and Design of Entrance	Coefficient k_e
Projecting from fill, socket end (groove-end)	0.20
Projecting from fill, square cut end	0.50
Headwall or headwall and wingwalls	
Socket end of pipe (groove-end)	0.20
Square-edge	0.50
Rounded (radius = 0.5D)	0.20
Mitered to conform to fill slope	0.70
End section conforming to fill slope	0.50
Beveled edges (33.7 degree or 45 degree bevels)	0.20
Side- or slope-tapered Inlet	0.20

Source: [FHWA, 1985]

TABLE 4.3 Entrance Loss Coefficients for Corrugated Metal Culverts

Type of Structure and Design of Entrance	Coefficient k_e
Projecting from fill (no headwall)	0.90
Headwall or headwall and wingwalls (square-edge)	0.50
Mitered to conform to fill slope (paved or unpaved slope)	0.20
End section conforming to fill slope	0.50
Beveled edges (33.7 degree or 45 degree bevels)	0.20
Side- or slope-tapered inlet	0.20

Source: [FHWA, 1985]

TABLE 4.4 Entrance Loss Coefficients for Concrete Box Culverts

Type of Structure and Design of Entrance	Coefficient k_e
Headwall parallel to embankment (no wingwalls)	
Square-edged on 3 edges	0.50
Rounded on 3 edges to radius of 1/12 barrel dimension or beveled edges on 3 sides	0.20
Wingwalls at 30 degree to 75 degree to barrel	
Square-edged at crown	0.40
Crown edge rounded to radius of 1/12 barrel dimension or beveled top edge	0.20
Wingwalls at 10 degrees to 25 degrees to barrel	
Square-edged at crown	0.50
Wingwalls parallel (extension of sides)	
Square-edged at crown	0.70
Side- or sloped-tapered Inlet	0.20

Source: [FHWA, 1985]

The exit loss (H_e) is generally set equal to the culvert velocity head, the downstream flow velocity being assumed to be zero. An expression for the friction loss (H_f) is derived from Manning's equation:

$$H_f = \left(\frac{29n^2L}{R^{1.33}} \right) \frac{V^2}{2g} \quad \text{Equation 4.2}$$

in which:

n = Manning's roughness coefficient

L = culvert barrel length (ft)

R = the hydraulic radius (ft)

g = the gravitational constant (32.2 ft/sec²)

V = mean velocity of flow in the culvert (ft/sec).

Rearranging Equation 4.1 it is seen that for full flow:

$$H = 1 + K_e + \left(\frac{29n^2L}{R^{1.33}} \right) \frac{V^2}{2g} \quad \text{Equation 4.3}$$

Equation 4.3 may be solved using the full flow nomographs located in Appendix A of the manual. Each nomograph is drawn for a particular barrel shape and material and a single value of Manning's "n" as noted on the respective charts. These nomographs may be used for other values of "n" by modifying the culvert length as directed in the instructions for use of the full-flow nomographs.

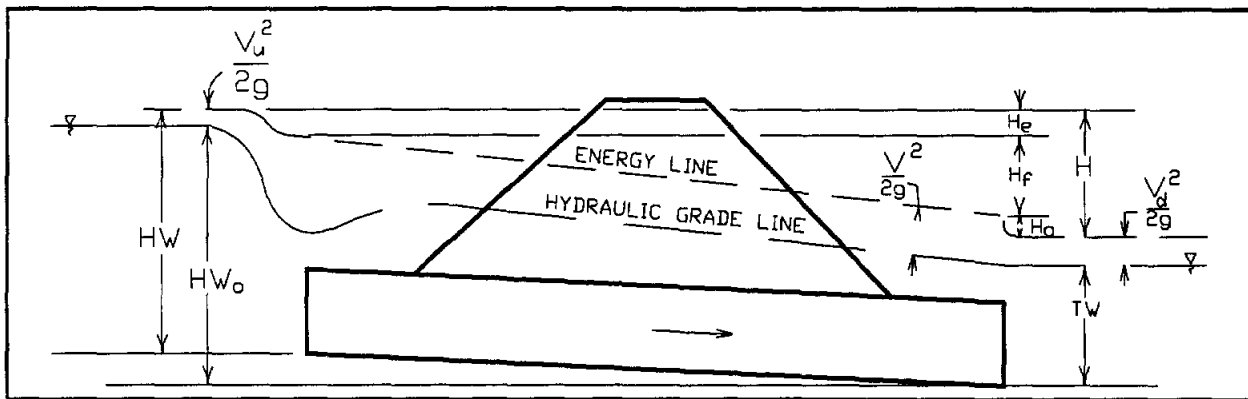

FIGURE 4.4 Hydraulic Elements of Pressure Flow Through Culverts (Source: (FHWA, 1985))

Figure 4.4 represents the various hydraulic elements of pressure, or full, flow through a culvert and reveals graphically that the head (H) is equivalent to the vertical distance between the energy grade line at the inlet and the energy grade line at the outlet. It also reveals the following relationship for full flow conditions:

$$H = H_e + H_f + H_o = HW + S_o L - \frac{V_d^2}{2g} - TW \quad \text{Equation 4.4}$$

in which:

HW = headwater depth (feet)

TW = tailwater depth (feet)

S_o = culvert barrel slope (ft/ft)

If the downstream flow velocity is neglected, equation 4.4 becomes:

$$H = HW + S_o L - TW \quad \text{Equation 4.5}$$

In culvert design it is generally required that the depth of the headwater (HW) be determined. Rearranging Equation 4.5, the following expression for HW is derived:

$$HW = H + TW - LS, \quad \text{Equation 4.6}$$

When the culvert outlet is submerged by the tailwater, the above equation can be solved directly to determine HW. However, when the tailwater is below the crown of the culvert, it becomes necessary to redefine d_2 which is taken as the greater of the following two values:

- 1) TW
- 2) $(d_c + D)/2$

in which:

d_c = critical depth in the culvert as read from the appropriate chart (ft)

TW = tailwater depth above the invert of the culvert outlet (ft)

D = height of the culvert (ft).

4.1.9.3 Step by Step Culvert Design Procedure

It is possible by involved hydraulic computations to determine the probable type of flow under which a culvert will operate for a given set of conditions. However, such computations can be avoided by determining the headwater necessary for a given discharge under both inlet and outlet flow conditions. The larger of the two will define the type of control and the corresponding headwater depth.

The culvert design procedures presented here are based on information provided in the Federal Highway Administration publication *Hydraulic Design of Highway Culverts* [FHWA, 1985]. The nomographs included in Appendix A of this manual cover the range of pipe and box culverts commonly used in drainage design. These nomographs correspond to Charts 1 through 15 and 29 through 40 in *Hydraulic Design of Highway Culverts*.

The following is the recommended procedure for selection of culvert size:

Step 1: List design data.

- a) Design discharge (Q), in cfs, with return period.
- b) Approximate length (L) of culvert, in feet.
- c) Slope of culvert. If grade is given in percent, convert to slope in feet per feet.
- d) Allowable headwater depth, in feet, which is the vertical distance from the culvert invert (flow-line) at the entrance to the water surface elevation permissible in the headwater pool or approach channel upstream from the culvert.
- e) Flow velocities in the channel upstream and downstream of the proposed culvert location.
- f) Type of culvert for first trial selection, including barrel material, barrel cross-sectional shape and entrance type.

Step 2: Determine the first trial culvert size.

Since the procedure given is one of trial and error, the initial trial size can be determined in several ways:

- a) Past experience and engineering judgement.
- b) By using an approximating equation such as $Q/6 = A$ from which the trial culvert dimensions are determined. A is the culvert barrel cross-sectional area and 6 is an estimate of barrel velocity in feet per second.

FIGURE 4.5 Culvert Design Form (Source: (FHWA, 1985))

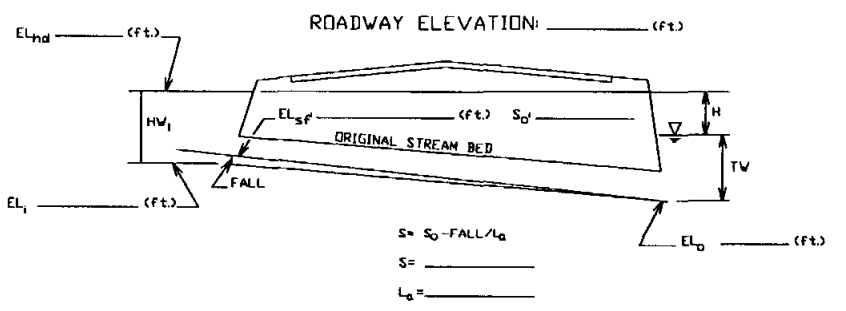
PROJECT: _____		STATION: _____		CULVERT DESIGN FORM												
SHEET _____ OF _____		DESIGNER/DATE: _____ / _____		REVIEWER/DATE: _____ / _____												
<p style="text-align: center;"><u>HYDROLOGICAL DATA</u></p> <p>SEE ADD'L SHTS. <input type="checkbox"/> METHOD: _____</p> <p> <input type="checkbox"/> DRAINAGE AREA: _____ <input type="checkbox"/> STREAM SLOPE: _____</p> <p> <input type="checkbox"/> CHANNEL SHAPE: _____</p> <p> <input type="checkbox"/> ROUTING: _____ <input type="checkbox"/> OTHER: _____</p> <p style="text-align: center;"><u>DESIGN FLOWS/TAILWATER</u></p> <table style="width:100%; border-collapse: collapse;"> <tr> <td style="width: 33%; text-align: center;">R.I. (YEARS)</td> <td style="width: 33%; text-align: center;">FLOW (cfs)</td> <td style="width: 33%; text-align: center;">TW (ft)</td> </tr> <tr> <td style="text-align: center;">_____</td> <td style="text-align: center;">_____</td> <td style="text-align: center;">_____</td> </tr> <tr> <td style="text-align: center;">_____</td> <td style="text-align: center;">_____</td> <td style="text-align: center;">_____</td> </tr> </table>			R.I. (YEARS)	FLOW (cfs)	TW (ft)	_____	_____	_____	_____	_____	_____	<p style="text-align: right;">ROADWAY ELEVATION: _____ (ft.)</p>  <p style="text-align: right;">$S = S_0 - \text{FALL} / L_a$</p> <p style="text-align: right;">S = _____</p> <p style="text-align: right;">L_a = _____</p>				
R.I. (YEARS)	FLOW (cfs)	TW (ft)														
_____	_____	_____														
_____	_____	_____														
<p><u>CULVERT DESCRIPTION:</u></p> <p>MATERIAL - SHAPE - SIZE - ENTRANCE</p>		<p>TOTAL FLOW</p> <p>Q (cfs)</p>	<p>FLOW PER BARREL</p> <p>Q/N (1)</p>	<u>HEADWATER CALCULATIONS</u>								<p>CONTROL HEADWATER ELEVATION</p>	<p>OUTLET VELOCITY</p>	<p>COMMENTS</p>		
				<u>INLET CONTROL</u>				<u>OUTLET CONTROL</u>								
				HW _i / D (2)	HW _i	FALL (3)	EL _{hd} (4)	TW (5)	d _c	$\frac{d_c + D}{2}$	h _o (6)	k _e	H (7)	EL _{ho} (8)		
<p><u>TECHNICAL FOOTNOTES:</u></p> <p>(1) USE Q/NB FOR BOX CULVERTS</p> <p>(2) HW_i / D = HW_i / D OR HW_i / D FROM DESIGN CHARTS</p> <p>(3) FALL = HW_i - (EL_{hd} - EL_{sf}) ; FALL IS ZERO</p>		<p>(4) EL_{hd} = HW_i + EL_i (INVERT OF INLET CONTROL SECTION)</p> <p>(5) TW BASED ON DOWN STREAM CONTROL OR FLOW DEPTH IN CHANNEL.</p>				<p>(6) h_o = TW OR (d + D)/2XWHICHEVER IS GREATER</p> <p>(7) $H = \left[1 + k_e \cdot (29n^2L) / R L^3 \right] \sqrt{Q^2 / 2g}$</p> <p>(8) EL_{ho} = EL_b + H + h_o</p>										
<p><u>SUBSCRIPT DEFINITIONS:</u></p> <p>a. APPROXIMATE</p> <p>f. CULVERT FACE</p> <p>hd. DESIGN HEADWATER</p> <p>hi. HEADWATER IN INLET CONTROL</p> <p>ho. HEADWATER IN OUTLET CONTROL</p> <p>i. INLET CONTROL SECTION</p> <p>o. OUTLET</p> <p>sf. STREAMBED AT CULVERT FACE</p> <p>tw. TAILWATER</p>		<p>COMMENTS/DISCUSSION</p>								<p><u>CULVERT BARREL SELECTED:</u></p> <p>SIZE: _____</p> <p>SHAPE: _____</p> <p>MATERIAL: _____</p> <p>ENTRANCE: _____</p>						

- c) Initially, utilize the inlet control nomographs for the culvert type selected. An HW/D must be assumed, say $HW/D = 1.5$, along with the given Q to determine a trial size.

Note: If any trial size is too large in dimension because of limited height of embankment or availability of size, multiple culverts may be used by dividing the discharge appropriately among the number of barrels used. Raising the embankment height or the use of pipe arch and box culverts with width greater than height should also be considered. Final selection should be based on applicability and costs.

Step 3: Find headwater depth for trial size culvert.

a) Assuming Inlet Control

- 1) Using the trial size from Step 2, find the headwater depth (HW) by use of the appropriate inlet control nomograph. Tailwater (TW) conditions are to be neglected in this determination. HW in this case is found by multiplying HW/D obtained from the nomographs by the height of culvert (D).
- 2) If HW is greater or less than allowable, try another trial size until HW is acceptable for inlet control before computing HW for outlet control.

b) Assuming Outlet Control

- 1) Approximate the depth of tailwater (TW), in feet, above the invert at the outlet for the design flood condition in the outlet channel.
- 2) For tailwater (TW) elevation equal to or greater than the top of the culvert at the outlet, set d^2 equal to TW and find HW by equation 4.7.

$$HW = H + d_2 - LS_o \quad \text{Equation 4.7}$$

in which:

HW = vertical distance in feet from culvert invert at entrance to the pool surface

H = head loss in feet as determined from the appropriate nomograph (Charts 8-14)

d_2 = vertical distance in feet from culvert invert at outlet to the hydraulic grade line

S_o = slope of barrel (feet/feet)

L = culvert length (feet).

- 3) For tailwater (TW) elevations less than the top of the culvert at the outlet, find headwater HW by Equation 4.7 as in Step b(2) above except that:

$$d_2 = (d_c + D)/2 \text{ or } TW \text{ (whichever is greater)}$$

in which:

d_c = critical depth in feet. Note: d_c cannot exceed D

D = height of culvert opening (feet).

Note: Headwater depth determined in Step b(3) becomes increasingly less accurate as the headwater computed by this method falls below the value:

$$D + (1 + k_s) \frac{v^2}{2g}$$

- c) Compare the headwater depths obtained in Step 3a and Step 3b (Inlet Control and Outlet Control). The higher headwater governs and indicates the flow control existing under the given conditions for the trial size selected.

- d) If outlet control governs and the HW is higher than is acceptable, select a larger trial size and find HW as instructed under Step 3b. (Inlet control need not be checked, since the smaller size was satisfactory for this control as determined under Step 3a.)

Step 4: Try additional culvert types or shapes.

Determine their size and HW by the above procedure.

Step 5: Compute outlet velocities for size and types to be considered in selection and determine need for channel protection.

- a) If outlet control governs in Step 3c above, outlet velocity equals Q/A_o , where A_o is the cross-sectional area of flow in the culvert barrel at the outlet. If d_c or TW is less than the height of the culvert barrel, use A_o corresponding to d_c or TW depth, depending on whichever gives the greater area of flow. A_o should not exceed the total cross-sectional area A of the culvert barrel.
- b) If inlet control governs in Step 3c, outlet velocity can be assumed to equal mean velocity in open-channel type flow in the barrel as computed by Manning's equation for the rate of flow, barrel size, roughness and slope of culvert selected.

Step 6: Record final selection of culvert with size, type, required and computed headwater, outlet velocity and economic justification.

Figure 4.5 provides a culvert design form which may be used to record the culvert computations and related data.

4.1.9.4 Example of Culvert Design Procedure

This section contains a complete example of the step-by-step culvert design procedure presented in the previous section.

Step 1: List design data.

- a) Design discharge (Q) = 200 cfs for the 25-year storm event.
- b) Approximate length (L) of culvert = 200 feet.
- c) Natural Stream Bed Slope = 1% = 0.01 ft/ft. Set the inlet invert at the natural streambed elevation (no fall).
- d) Base the design headwater on the shoulder elevation of 110.0 with a two foot freeboard. Therefore, the design headwater is 108.0 - 100.0 = 8.0 feet.
- e) Flow velocities in the channel upstream and downstream of the proposed culvert location.
- f) Design a circular pipe culvert for this site. Consider the use of a corrugated metal pipe with standard 2-2/3 by 1/2 inch corrugations and beveled edges and concrete pipe with a groove end.

Step 2: Determine the first trial culvert size.

The initial trial size for the corrugated metal pipe culvert may be computed using the approximation of $A = 200/6 = 33.3$ square feet. Therefore, the pipe diameter, $D = \sqrt{4 \times 33.3/\pi} = 6.5$ ft = 78 inches. A more standard pipe size of 72 inches will be used for the first trial.

Step 3: Find headwater depth for trial size culvert.

- a) Assuming Inlet Control

Using a pipe diameter of 72 inches, the headwater depth (HW) is determined using FHWA Chart 2 in Appendix A. The computed headwater depth $HW = 0.96 \times 72 = 69.12" = 5.80'$.

- b) Assuming Outlet Control

- 1) Assume that the tailwater depth for 25-Year Flood is 3.5 feet.

FIGURE 4.6 Example Culvert Design Form (Source: (FHWA, 1985))

PROJECT: <u>Culvert Design Example Problem</u> <u>Montgomery County Drainage Criteria Manual</u>		STATION: <u>1+00</u> SHEET <u>1</u> OF <u>1</u>		CULVERT DESIGN FORM DESIGNER/DATE: <u>KNW</u> / <u>7/18</u> REVIEWER/DATE: <u>RDD</u> / <u>7/19</u>													
<p style="text-align: center;"><u>HYDROLOGICAL DATA</u></p> <p>SEE ADD'L SHTS. <input type="checkbox"/> METHOD: <u>Montgomery Co. Runoff Rate Curves</u> <input type="checkbox"/> DRAINAGE AREA: <u>125 ac</u> <input type="checkbox"/> STREAM SLOPE: <u>1.0%</u> <input type="checkbox"/> CHANNEL SHAPE: <u>Trapezoidal</u> <input type="checkbox"/> ROUTING: <u>N/A</u> <input type="checkbox"/> OTHER: _____</p> <p style="text-align: center;"><u>DESIGN FLOWS/TAILWATER</u></p> <table style="width:100%; border-collapse: collapse;"> <tr> <td style="width:33%;"><u>R.I. (YEARS)</u></td> <td style="width:33%;"><u>FLOW (cfs)</u></td> <td style="width:33%;"><u>TW (ft)</u></td> </tr> <tr> <td style="text-align:center;"><u>25</u></td> <td style="text-align:center;"><u>200</u></td> <td style="text-align:center;"><u>3.5</u></td> </tr> </table>		<u>R.I. (YEARS)</u>	<u>FLOW (cfs)</u>	<u>TW (ft)</u>	<u>25</u>	<u>200</u>	<u>3.5</u>	<p style="text-align: center;">ROADWAY ELEVATION: <u>110.0</u> (ft.)</p> <p style="text-align: right;"> $S = S_0 - \text{FALL}/L_0$ $S = \underline{0.01}$ $L_0 = \underline{200}$ </p>									
<u>R.I. (YEARS)</u>	<u>FLOW (cfs)</u>	<u>TW (ft)</u>															
<u>25</u>	<u>200</u>	<u>3.5</u>															
<p><u>CULVERT DESCRIPTION:</u> MATERIAL - SHAPE - SIZE - ENTRANCE</p>		<p>TOTAL FLOW Q (cfs)</p>	<p>FLOW PER BARREL Q/N (1)</p>	<u>HEADWATER CALCULATIONS</u>										<p>CONTROL HEADWATER ELEVATION</p>	<p>OUTLET VELOCITY</p>	<p>COMMENTS</p>	
				<u>INLET CONTROL</u>					<u>OUTLET CONTROL</u>								
				HW _i /D (2)	HW _i (3)	FALL (3)	EL _{hi} (4)	TW (5)	d _c	$\frac{d_c + D}{2}$	h ₀ (6)	K _e	H (7)	EL _{ho} (8)			
C.M.P. Circular 72 in. -in headwall Bevel 45		200	200	0.95	5.7		105.7	3.5	3.9	4.9	4.9	0.20	2.5	105.4	105.7	9.2	Try 60' CMP
C.M.P. Circular 60 in. -in headwall Bevel 45		200	200	1.36	6.8		106.8	3.5	4.0	4.5	4.5	0.20	6.0	108.5	108.5	11.8	Try 60' RCP
R.C.P. Circular 60 in. -Groove End		200	200	1.35	6.7		106.7	3.5	4.0	4.5	4.5	0.20	3.0	105.5	106.7	15.6	Try 54' RCP
R.C.P. Circular 54 in. -Groove End		200	200	1.77	8.0		108.0	3.5	4.0	4.3	4.3	0.20	4.7	107.0	108.0	15.2	
<p><u>TECHNICAL FOOTNOTES:</u></p> <p>(1) USE Q/NB FOR BOX CULVERTS</p> <p>(2) HW_i/D = HW_i/D OR HW_i/D FROM DESIGN CHARTS</p> <p>(3) FALL = HW_i - (EL_{hd} - EL_{sf}) ; FALL IS ZERO</p>				<p>(4) EL_{hi} = HW_i + EL_i (INVERT OF INLET CONTROL SECTION)</p> <p>(5) TW BASED ON DOWN STREAM CONTROL OR FLOW DEPTH IN CHANNEL.</p>					<p>(6) h₀ = TW OR (D/2)XWHICHEVER IS GREATER</p> <p>(7) $H = \left[1 + K_e + (29n^2 L) / R L^3 \right]^{1/2} \sqrt{D}$</p> <p>(8) EL_{ho} = EL₀ + H + h₀</p>								
<p><u>SUBSCRIPT DEFINITIONS:</u></p> <p>a. APPROXIMATE f. CULVERT FACE hd. DESIGN HEADWATER hi. HEADWATER IN INLET CONTROL ho. HEADWATER IN OUTLET CONTROL i. INLET CONTROL SECTION o. OUTLET sf. STREAMBED AT CULVERT FACE tw. TAILWATER</p>		<p>COMMENTS/DISCUSSION</p> <p>High Outlet Velocity - Outlet protection or larger conduit may be necessary.</p>					<p><u>CULVERT BARREL SELECTED:</u></p> <p>SIZE: <u>54 in.</u></p> <p>SHAPE: <u>Circular</u></p> <p>MATERIAL: <u>Concrete</u> n: <u>0.012</u></p> <p>ENTRANCE: <u>Groove End</u></p>										

- 2) The tailwater elevation is less than the top of the culvert.
- 3) Critical depth d_c is determined using FHWA Chart 4 in Appendix A. For this culvert, $d_c = 3.9$ feet. Therefore, $d_2 = (d_c + D)/2 = (3.9 + 6)/2 = 4.9$ feet. The headwater depth is computed using equation 4.7:

$$HW = H + d_2 - LS_o = 2.5 + 3.9 - 200 \times 0.01 = 5.7$$

- c) Since the computed Inlet Control Headwater (5.8 feet) is higher than the computed Outlet Control Headwater (5.7 feet) for this culvert, the Inlet Control Headwater governs.
- d) The computed headwater for the 72-inch corrugated metal pipe culvert is lower than the allowable headwater. Therefore, it is appropriate to reduce the pipe diameter for the second trial.

Step 4: Try additional culvert types or shapes.

The culvert design form shown in Figure 4.6 shows the sequence of trial sizes and configurations for the example culvert. As indicated, the second trial indicates that the computed headwater depth for a 60-inch corrugated metal pipe culvert is greater than the allowable value. Therefore, a third trial is performed using a 60-inch groove end concrete pipe. For the fourth and final trial, the diameter of the concrete pipe is reduced to 54 inches, which provides a reasonable headwater value.

Step 5: Compute outlet velocities for size and types to be considered in selection and determine need for channel protection.

- a) Inlet control governs the pipe size for the final trial.
- b) Outlet velocity is computed assuming normal depth in the culvert barrel. The computed normal depth for a flow rate of 200 cfs in a 54-inch concrete pipe at a 1% slope is 3.5 feet, and the resulting flow velocity is 15.2 feet per second. This outlet velocity high enough to require erosion protection at the culvert outlet.

Step 6: Record final selection of culvert with size, type, required and computed headwater, outlet velocity and economic justification.

Figure 4.6 presents an example of a culvert design form which has been completed for the example described in this section.

4.2 BRIDGES

4.2.1 Design Storm Frequency

At a minimum, bridges must be designed to pass the fully developed 100-year design flow without causing backwater problems, structural damage, or erosion. No increase in 100-year water surface elevations will be allowed either upstream or downstream of the bridge unless authorization is given by the Montgomery County Drainage Administrator.

4.2.2 Bridge Alignment

Wherever possible, bridges shall intersect the channel at an angle of 90 degrees.

4.2.3 Bridge Length

Newly constructed bridges must be designed to completely span the existing or proposed channel so that the channel will pass under the bridge without modification. Bridges and bents constructed on existing or interim channels shall be designed to accommodate the ultimate channel section with a minimum of structural modification. Energy losses due to flow transitions shall be minimized. In addition, provision must be made for future channel enlargements should they become necessary.

4.2.4 Piers and Abutments

Bents and abutments must be aligned parallel to the longitudinal axis of the channel so as to minimize obstruction of the flow. Bents shall be placed as far away from the channel center-line as possible and if possible should be eliminated entirely from the channel bottom.

4.2.5 Minimum Low Chord Elevation

The low chord of all bridges must be located at least one foot above the 100-year flood elevation, or at or above the level of natural ground, whichever is higher.

4.2.6 Erosion Control

Increased turbulence and velocities associated with flow in the vicinity of bridges requires the use of erosion protection in affected areas. SECTION 6 of this manual contains information concerning erosion protection requirements for open channels.

4.2.7 Hydraulic Design of Bridges

Three different regimes are possible for flows through a bridge structure. These regimes are denoted Class A, Class B, and Class C low flow. **Class A Low Flow** occurs when the water surface through the bridge is above critical. In other words, the flow is sub-critical. **Class B Low Flow** can exist for either sub-critical or super-critical flow conditions. For either condition, Class B Low Flow occurs when the water surface profile passes through critical depth within the bridge constriction. **Class C Low Flow** occurs where the water surface profile stays super-critical through the bridge constriction.

The following basic procedure should be followed in the hydraulic design of bridge structures:

- 1) **Right-of-Way:** Determine the ultimate right-of-way width and the dimensions of the required ultimate channel cross-section at the crossing location.
- 2) **Water Surface Elevations:** Determine existing and ultimate 100-year water surface elevations at the proposed crossing location.
- 3) **Bridge Elevation:** Establish the minimum low chord elevation of the bridge as the higher of:
 - a) at least one foot above the existing 100-year flood elevation, b) at least one foot above the ultimate 100-year flood elevation, or c) at or above the level of natural ground.
- 4) **Bridge Length:** Establish the total length of the bridge to allow the accommodation of the ultimate channel section with a minimum of structural modification.
- 5) **Bridge Piers:** Locate the bridge pier bents in such a way as to keep piers as far away from the channel center-line as possible or, if possible, to eliminate them entirely from the channel bottom. Due consideration should be given to the existing as well as the ultimate channel sections when locating the pier bents.
- 6) **Effects of Bridge:** Use the HEC-2 computer program, or appropriate alternative methods approved by the Montgomery County Drainage Administrator, to determine the effect of the bridge structure on existing and ultimate 100-year flood elevations upstream of the crossing.
- 7) **Erosion Protection:** Use the results of the HEC-2 or alternative hydraulic analysis to determine existing and ultimate flow velocities through the bridge opening. Determine the extent of slope protection required to prevent erosion damage in the vicinity of the bridge.

SECTION 5 SECONDARY DRAINAGE AND OVERLAND FLOW DESIGN

It is often infeasible in certain areas to convey the runoff from extreme rainfall events entirely via an underground storm sewer system. Local flooding will occur in areas away from the primary drainage channels because it is simply uneconomical to provide a storm sewer pipe large enough to totally carry the infrequent, severe storm events. For this reason, a sheet flow analysis is required so that street design and alignment assure that excess runoff from extreme storm events will be safely conveyed to primary drainage channels. Sheet flow corridors shall be designated and all required right-of-way dedicated to the County. Special consideration must also be given for off-site sheet flows and their impacts on planned developments.

The discussion presented in this section will be directed primarily at curb-and-gutter streets with underground storm sewers. Roadside ditch systems are acceptable in certain instances, but are not preferred.

5.1 RUNOFF ANALYSES

5.1.1 Design Storm Frequencies

Flooding in Montgomery County is generally associated with one of two types of severe rainfall events. The first type is a localized high-intensity rainfall of short duration which floods a small localized area and causes ponding of water and interruption of traffic flow. The second type is a more generalized rainfall of longer duration which can cause more widespread flooding and can result in severe damage and loss of life. This second type of storm event is generally used to design drainage channels which serve large watersheds.

In designing storm sewers for draining small developments, it is the localized high intensity, short duration rainfall event which is used. However, since these storm sewers usually drain into open channels, which are used to convey the runoff from larger areas, the design must take into consideration the interaction of these two systems.

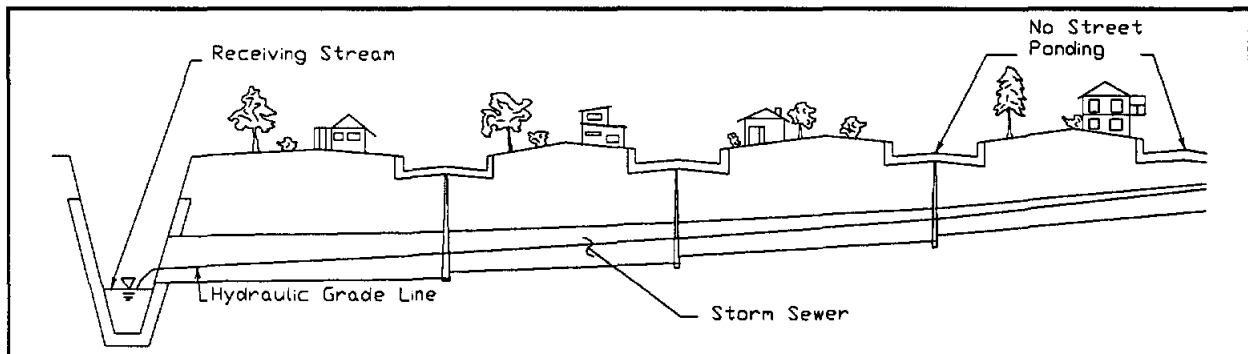

FIGURE 5.1 Effect of Low Starting Elevation on Storm Sewers

Figured 5.1 through 5.3 illustrate the effect of three outlet conditions on the hydraulic grade line of a storm sewer. Assuming the outlet channel is at its 25-year water level, it can be seen from Figure 5.1 that the hydraulic grade line for the standard design condition remains at or below the gutter level at the furthest inlet. For this condition, there is no street ponding and the storm sewers are functioning at or below their design capacity.

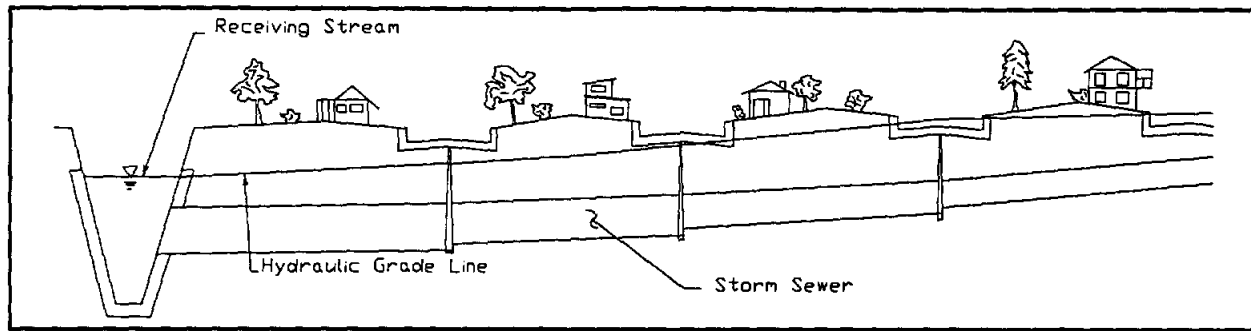

FIGURE 5.2 Effect of Medium Starting Elevation on Storm Sewers

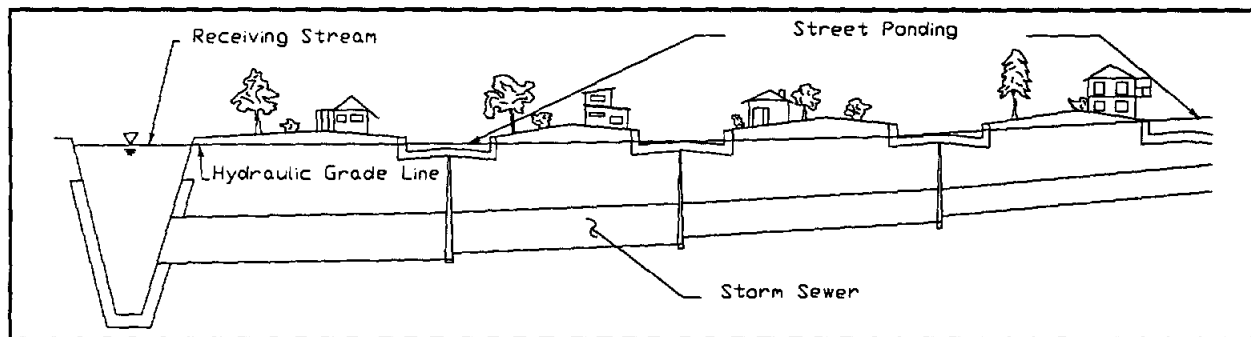

FIGURE 5.3 Effect of High Starting Elevation on Storm Sewers

Figures 5.2 and 5.3 illustrate cases where the tailwater condition is above the design level. Street ponding begins to occur throughout the storm sewer drainage system, as the storm sewers are unable to operate at their design capacity. This local flooding situation could also occur when the tailwater is below design conditions if local rainfall is in excess of that used in the design of the storm sewer system. As this widespread street ponding starts to occur, provisions must be made to limit the depth of ponding to a level below that which will cause significant property damage. In general, 100-year flood elevations shall be considered unacceptable when they exceed the lowest of the following: 1) one foot above natural ground; 2) one foot over top of curb; or 3) one foot below the lowest slab elevation.

5.1.2 General Design Criteria

Storm sewers shall be designed to carry the design storm peak flow. Use of the Rational Method for drainage areas less than 50 acres or the drainage area-discharge curves for areas between 50 and 640 acres is acceptable. A detailed description of these techniques is contained in Section 2 of this manual.

For all storm sewer systems or enclosed reaches of open channels, hydraulic calculations and hydraulic profiles along with the construction plans of the closed-conduit system must be submitted to the County Drainage Administrator for review.

A preliminary design should first be performed utilizing the design storm and the Rational Method in conjunction with the design curves shown in Figure 5.4. Then, if necessary, adjust the sizes of the pipes or boxes to meet the required criteria outlined in SECTION 5.2.1.

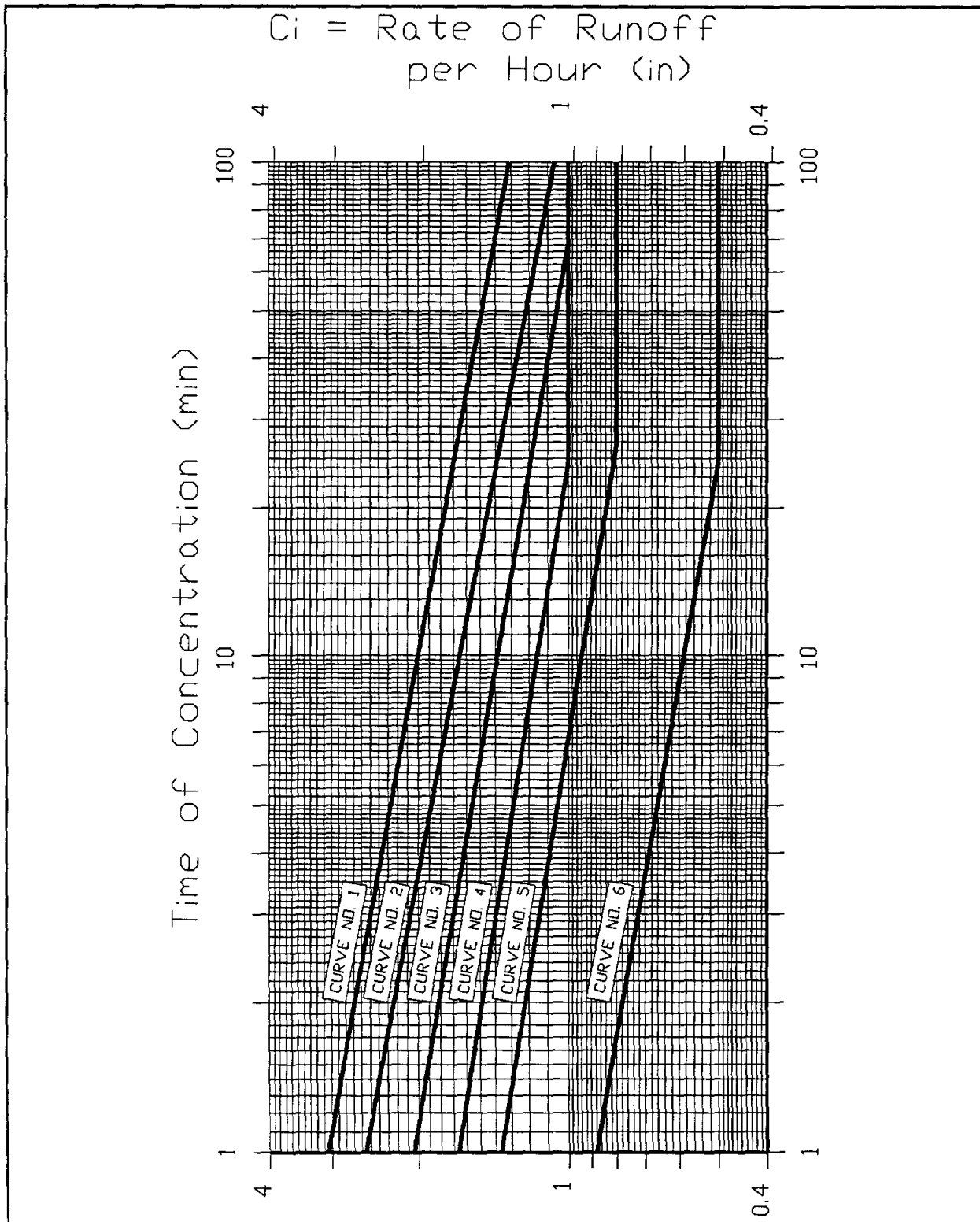

FIGURE 5.4 Rainfall-Runoff Curves for Storm Sewer Design (Source: City of Houston)

TABLE 5.1 Curve Numbers for Rainfall-Runoff Curves

Curve Number	Land Use
1	Highly developed business areas (Downtown, Shopping Centers, etc.).
2	Multi-family residential areas (Apartments, Townhouses, etc.).
3	Composite areas (Single & Multi-family Residential, Commercial, etc), business and industrial parks.
4	Single-family residential areas.
5	Railroad yards, suburban residential areas (Minimum 1-acre lots).
6	Developed park areas.

Source: City of Houston

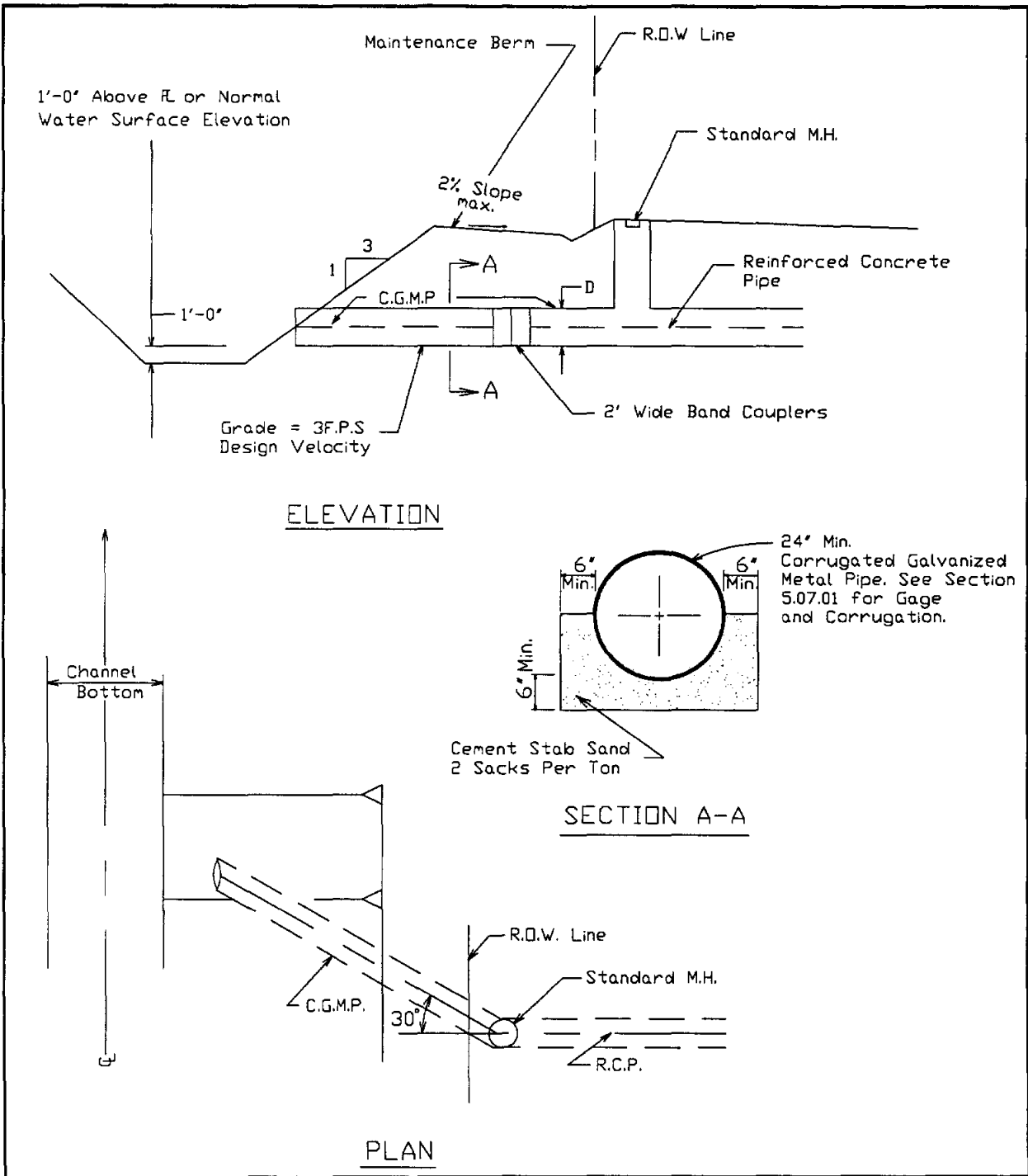

FIGURE 5.5 Typical Storm Sewer Outfall Structure (24-inch to 42-inch)

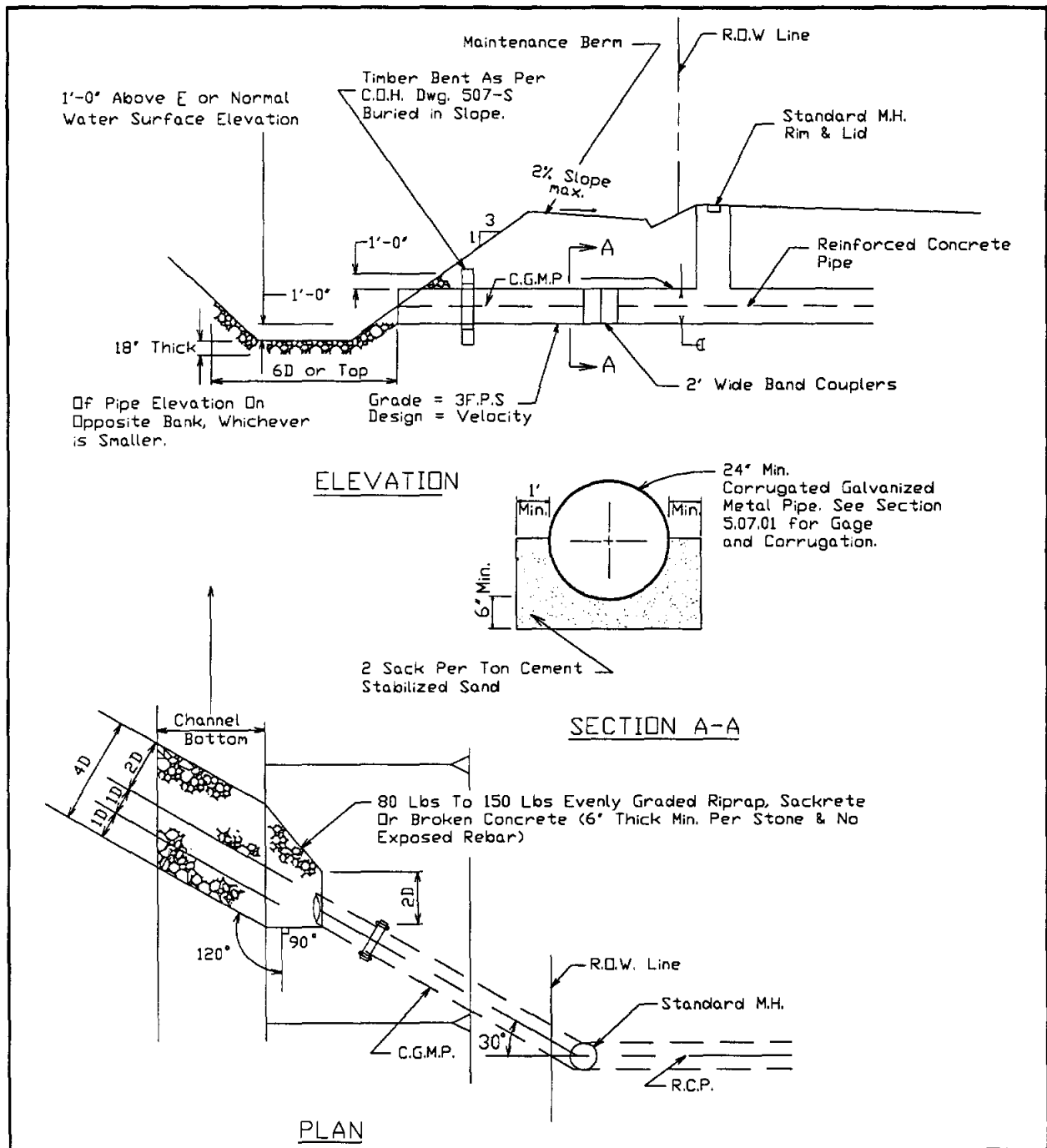

FIGURE 5.6 Typical Storm Sewer Outfall Structure (42-inch and larger)

5.2 STORM SEWER DESIGN

5.2.1 Design Criteria for Storm Sewers

The following specific criteria and requirements shall apply to the design and construction of storm sewers in Montgomery County. The following criteria were taken primarily from *General Design Requirements for Sanitary Sewers, Storm Sewers, Water Lines, and Paving*, [City of Houston, 1983]:

- 1) **Starting Elevation:** Calculation of the hydraulic grade line for design conditions in a specific branch of storm sewer shall proceed upstream from the level of the 25-year water surface elevation in the outfall channel.
- 2) **Minimum Diameter:** The minimum diameter of a pipe in a storm sewer line shall be 24".
- 3) **Manning Coefficient:** The Manning's "n" value to be used in a reinforced concrete pipe storm sewer shall be 0.013. For corrugated metal pipe, the "n" value shall be as shown in Table 5.2.

TABLE 5.2 Values of Manning Roughness Coefficient for Corrugated Metal Pipe

Corrugation (Span x Depth)	Manning's "n" Value
2-2/3" x 1/2"	0.024
3" x 1"	0.027
5" x 1"	0.027
6" x 2"	0.030

Source: [HCFCD, 1984]

- 4) **Flow Velocities:** The minimum velocity of flow to be allowed in a section of storm sewer flowing full shall be 3 fps. The maximum velocity shall be 10 fps.
- 5) **Overland Flow:** Provisions must be made for all adjacent undeveloped areas with natural drainage patterns directing overland flow into and across planned areas of development.
- 6) **Required Items:** Before a particular storm sewer design will be reviewed, the following items must be presented:
 - a) **Drainage Area Map:** A contour and drainage area map showing all pertinent sub-areas, including contributing off-site areas.
 - b) **Flow Calculations:** A listing of all relevant hydrologic design flow calculations, which shall include all contributing off-site flows.
 - c) **Hydraulic Calculations:** Calculations for determining the hydraulic gradient, along with a profile which illustrates the results.
 - d) **Plan View Drawing:** A plan showing the location of all manholes and inlets, and the alignment of all storm sewers in the right-of-way.
 - e) **Profile View Drawing:** A profile showing the placement of storm sewers and the locations of all pipe size changes, grade changes, and pipe intersections.
- 7) **Construction Specifications:** All storm sewers and appurtenant construction shall conform to the City of Houston Form E-14-62 [City of Houston, 1980], City of Houston Drawing Nos. 529-S-1, 530-S-1, 530-S-2, and all subsequent revisions, or approved equivalent.
- 8) **Concrete Pipe:** All storm sewers shall be constructed with reinforced concrete pipe or approved equal. Corrugated galvanized metal pipe, or other approved equal, may be used only at the storm sewer outfall into grass-lined channels.

- 9) **Alignment:** All cast-in-place concrete storm sewers shall follow the alignment of the right-of-way or easement. All precast concrete pipe storm sewers shall be typically designed in a straight line or shall conform to the City of Houston Form E-14-2 [City of Houston, 1980], Drawing Numbers 529-S-1, 530-S-1, 530-S-2 and all subsequent revisions, or approved equal.
- 10) **Inlet Lead Alignment:** All storm sewer inlet leads shall be designed in a straight line alignment.
- 11) **Right-of-Way:** Storm sewers shall be located in public street rights-of-way or in easements that will not prohibit future maintenance access. In most cases where easements are restricted to storm sewers, the pipe should be centered within the limits of the easement.
- 12) **Soil Borings:** For all storm sewers having a cross-sectional area equivalent to a forty-two inch (42") inside diameter pipe or larger, soil borings with logs shall be made along the alignment of the storm sewer at intervals not to exceed five hundred feet (500') and to a depth not less than three feet (3') below the proposed invert of the sewer. The required bedding of the storm sewer as determined from these soil borings shall be shown in the profile of each respective storm sewer. The design engineer shall inspect the open trench and may authorize changes in the bedding indicated on the plans. Such changes shall be shown on the record drawings and, along with soil boring logs, submitted to the County Drainage Administrator's Office. All bedding shall be constructed as specified in the City of Houston Form E-14-62 [City of Houston, 1980] and all subsequent revisions, or approved equal.
- 13) **Outfall Erosion Control:** All storm sewer outfalls shall conform with the requirements and specifications defined in SECTION 6 EROSION AND SEDIMENT CONTROL, and Figures 5.5 and 5.6.

5.2.2 General Design Methods

Design of a storm sewer system should proceed as follows:

- 1) **Starting Elevation:** Determine the 25-year water surface elevation in the receiving channel at the storm sewer outfall using appropriate backwater calculations.
- 2) **Peak Flow Rates:** Determine the design flow rates for all sections of storm sewer based on drainage area size, time of concentration, density of development, and the design curves shown on Figure 5.4.
- 3) **Size Pipes:** Assuming storm sewer pipes are full at design flows, determine the appropriate sizes for all sections of storm sewer using Manning's equation and assuming uniform flow conditions.
- 4) **Compute Backwater:** Begin backwater calculations at the 25-year water surface elevation in the outfall channel and plot the hydraulic gradient through the system for the design storm. Include all relevant energy losses. The hydraulic gradient must not exceed the roadway gutter flow-line elevation.

5.2.3 Specific Design Flow Frequency Criteria

The recommended design flow frequency criteria to be used for continuous closed-conduit systems are given below:

- 1) **General Requirement:** For all drainage areas, the design flows shall be determined utilizing the Rational Method (with a 5-year rainfall intensity) and storm sewer curves shown in Figure 5.4 as a minimum. The conduit shall be designed in accordance with the methodology outlined in Section 5.3.2.

- 2) **Areas Over 100 Acres:** For portions of the system serving areas between 100 acres and 200 acres, it is additionally required that the 25-year hydraulic grade line be at or below the gutter line for the portion of the system which drains 100 or more acres. For this computation, the 25-year discharge for fully developed conditions based on the drainage area versus peak discharge curves for Montgomery County (See SECTION 2) should be used. A 25-year design water surface should be assumed in the outfall channel.
- 3) **Areas Over 200 Acres:** For portions of the system serving an area larger than 200 acres, the 100-year flow for fully developed conditions shall be used (based on the drainage area versus discharge curves in Section 2) to insure that the 100-year hydraulic grade line will be below the natural ground elevation at all points along this portion of the closed system. A 25-year design water surface should be assumed in the outfall channel.
- 4) **Inlet Capacity:** For systems designed in accordance with (2) or (3), sufficient additional inlet capacity shall be provided to allow for entry into the closed-conduit system of runoff in excess of the runoff conveyed through the storm sewer system up to the design capacity of the closed-conduit system.
- 5) **Overland Flow:** For all areas, overland flow shall be considered as discussed in SECTION 5.3. Closed systems adjoined to an upstream open channel shall be designed for the 100-year ultimate discharge.

5.2.4 Starting Water Surface Elevation

Storm sewers generally drain into open channels. In the design of storm sewer systems, therefore, it is required that the existing and ultimate 25-year water surface elevations be computed for the outfall channel, with the higher being used as the starting point for hydraulic grade line computations for the design of storm sewers.

5.2.5 Friction Losses in Storm Sewers

Friction losses in storm sewer systems shall be computed using Manning's equation.

5.2.6 Minor Losses in Storm Sewers

Head losses at structures such as inlets and manholes, usually termed "minor losses," shall be determined in the design of closed conduits. The design engineer should determine the relative significance of the minor losses and their applicability to the design. If they are insignificant, they may be omitted.

The equation for head loss at the entrance to a pipe is given as follows:

$$HeadLoss = K \frac{V^2}{2g} \quad \text{Equation 5.1}$$

in which:

K = entrance loss coefficient. (See Table 5.3)

V = flow velocity in pipe (fps).

The equation for the head loss (feet) at an inlet or manhole is as follows:

TABLE 5.3 Coefficients for Entrance Losses

Type of Entrance	Coefficient (K)
Pipe, Concrete	
Projecting from fill, socket end (groove-end)	0.20
Projecting from fill, sq. cut end	0.50
Headwall or headwall and wingwalls	
Socket end of pipe (groove-end)	0.20
Square-edge	0.50
Rounded (radius = 1/12D)	0.20
Mitered to conform to fill slope	0.70
Inlet or Manhole at beginning of line	1.25

Sources: [FHWA, 1985], [City of Waco, undated]

$$HeadLoss = \frac{V_2^2 - KV_1^2}{2g} \quad \text{Equation 5.2}$$

in which:

V_1 = velocity in the upstream pipe (fps).

V_2 = velocity in the downstream pipe (fps).

K = junction or structure coefficient of loss. (See Table 5.4).

TABLE 5.4 Coefficients for Losses at Structures

Type of Structure	Coefficient (K)
Inlet on main line	0.50
Inlet on main line with branch lateral	0.25
Manhole on main line with 22-1/2 degree lateral	0.75
Manhole on main line with 45 degree lateral	0.50
Manhole on main line with 60 degree lateral	0.35
Manhole on main line with 90 degree lateral	0.25

Source: [City of Waco, undated]

5.2.7 Appurtenant Storm Sewer Structures

Appurtenant storm sewer structures include storm sewer manholes, inlets, and outfall.

5.2.7.1 Storm Sewer Manholes

Manholes shall be placed at the location of all pipe size or cross section changes, pipe sewer intersections, pipe sewer grade changes, street intersections, at maximum intervals of 500 feet measured along the center-line of the pipe sewer, and at all inlet lead intersections with the pipe sewer where precast concrete pipe sewers are designed.

5.2.7.2 Storm Sewer Inlets

Two types of inlets are recommended for use in Montgomery County; the Type "BB" Inlet and the Type "C-1" Inlet. All inlets shall be constructed as specified in the City of Houston Form E-14-62 [City of Houston, 1980] and all subsequent revisions.

The capacity of inlets shall be determined as shown in Step 7 of SECTION 5.3.4 of this manual. All inlets shall be designed to carry at least the design storm frequency runoff.

Curb inlets must be spaced to handle the design storm discharge so that the hydraulic gradient does not exceed the roadway gutter elevation. Inlets shall be spaced so that the maximum travel distance of water in the gutter will not exceed six hundred feet (600') in one direction for residential streets and three-hundred feet (300') in one direction on major thoroughfares and streets within commercial developments. Curb inlets shall be located on side streets which intersect major thoroughfares in all original designs or developments. Special conditions warranting other locations of inlets shall be determined on a case-by-case basis.

5.2.7.3 Storm Sewer Outfalls

Storm sewer outfalls shall be designed in accordance with Figures 5.5 and 5.6.

5.3 OVERLAND FLOW DESIGN

When the capacity of the underground system is exceeded and street ponding begins to occur, careful planning can reduce or eliminate the flood hazard for adjacent properties. Street layout and pavement grades are the key components in developing a successful system which can convey excess storm runoff to an outfall channel designed to carry the 100-year storm runoff. The following design methodology and example are derived from the *Criteria Manual for the Design of Flood Control and Drainage Facilities in Harris County, Texas* [HCFCD, 1984].

5.3.1 Land Plan and Street Layout

Designing an effective overland drainage system must begin with the land plan and street layout. Awareness of overland flow problems in this early phase of the development process can reduce costly revisions and delays later on in the project. When designing drainage systems, attention should be given to special problems created by the topography. Excessive street cuts which can create ponding levels that hamper vehicle access and/or present a flood hazard must be avoided. Proper engineering foresight in the design of items such as emergency relief swales or underground systems can solve these potential problems.

The maximum allowable ponding level in a street is the lowest of the following elevations:

- 1) one foot above natural ground
- 2) one foot above top of curb
- 3) one foot below the lowest slab elevation.

The design engineer must determine whether the storm sewer system can convey flows from a 100-year storm event without ponding water in the street at levels that exceed the maximum allowable level. The 100-year discharge can be obtained by following the procedures outlined in Section 2. A 25-year tailwater condition should be assumed in the outlet channel. If storm sewer backwater calculations indicate that the allowable level is exceeded, the engineer must analyze the street system and verify that the excess flows will be able to reach the outfall channel without exceeding the maximum allowable ponding level. In making this analysis, the engineer can account for the portion of flows that would be carried by the sewer system in addition to the street system, assuming a 25-year tailwater condition.

Figure 5.7 illustrates a cul-de-sac street which slopes downhill and is designed so that sheet flow can only escape through building lots. Figure 5.8 illustrates a more acceptable alternative.

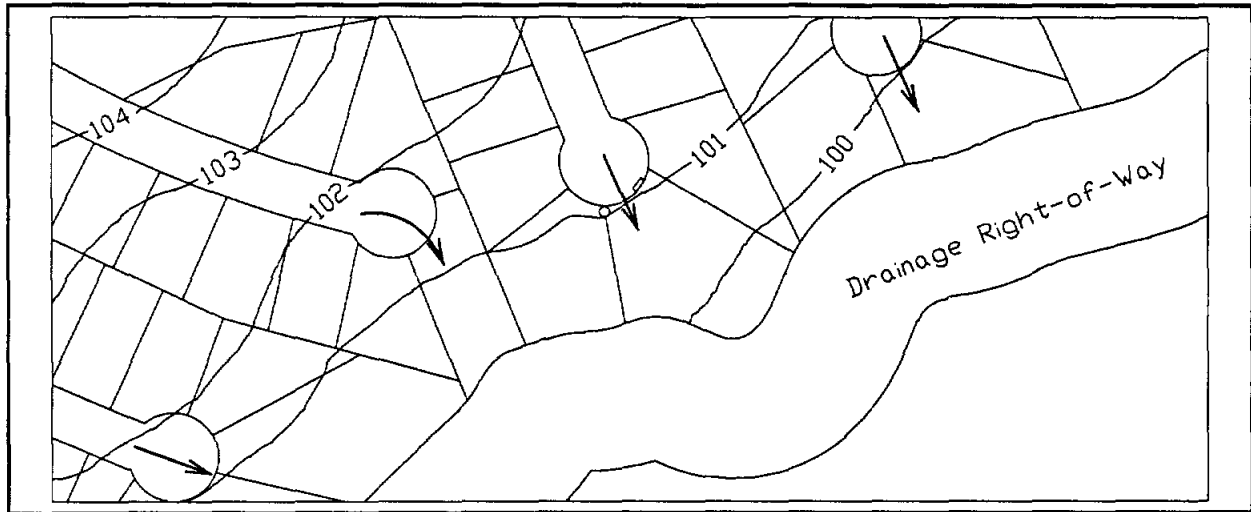

FIGURE 5.7 Undesirable Overland Flow Pattern for Cul-de-sac Street

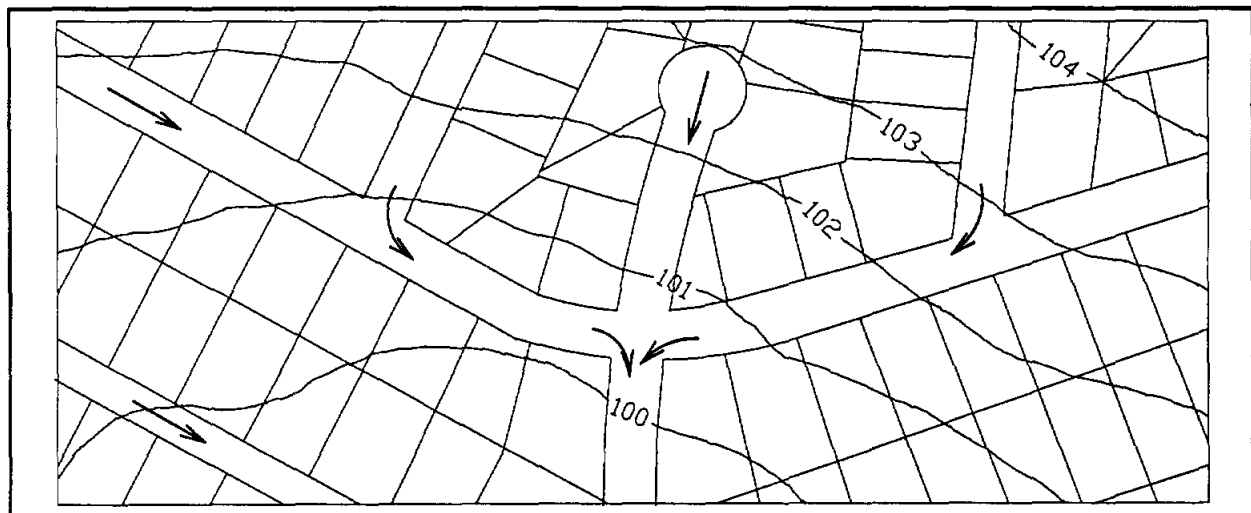

FIGURE 5.8 Acceptable Overland Flow Pattern for Cul-de-sac Street

Figure 5.9 illustrates a curve or turn in a roadway which is placed in a low area such that sheet flow entering that curve or turn can escape only through existing building lots. Figure 5.10 illustrates an acceptable alternative.

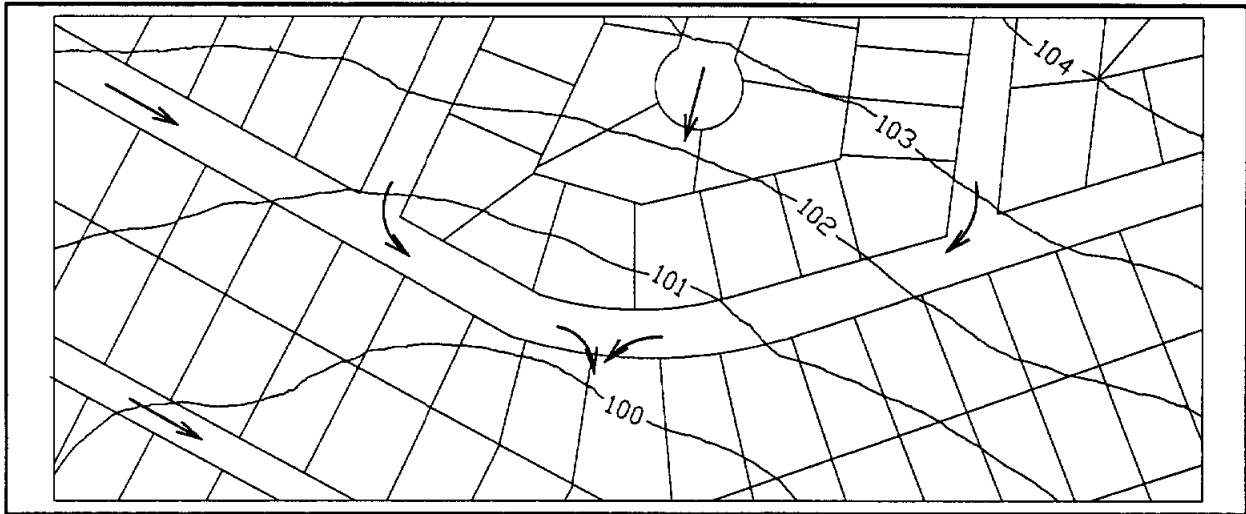

FIGURE 5.9 Undesirable Overland Flow Pattern at Roadway Curve

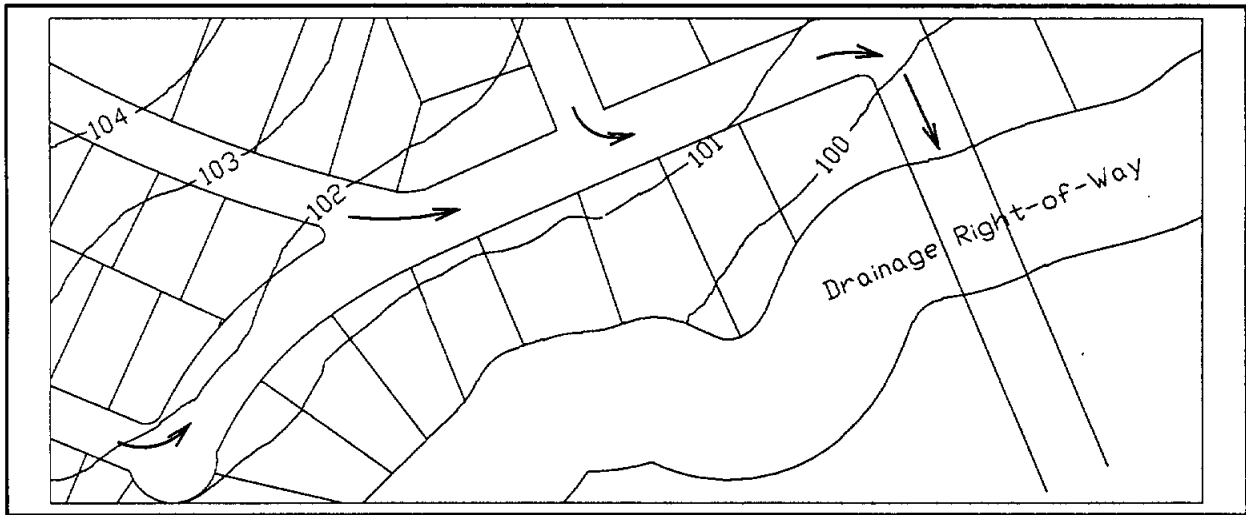

FIGURE 5.10 Acceptable Overland Flow Pattern at Roadway Curve

Figure 5.11 illustrates a situation in which many streets intersect a single street which is lower than the intersecting streets so that sheet flow down the streets can escape only through existing building lots. Figure 5.12 illustrates an acceptable alternative.

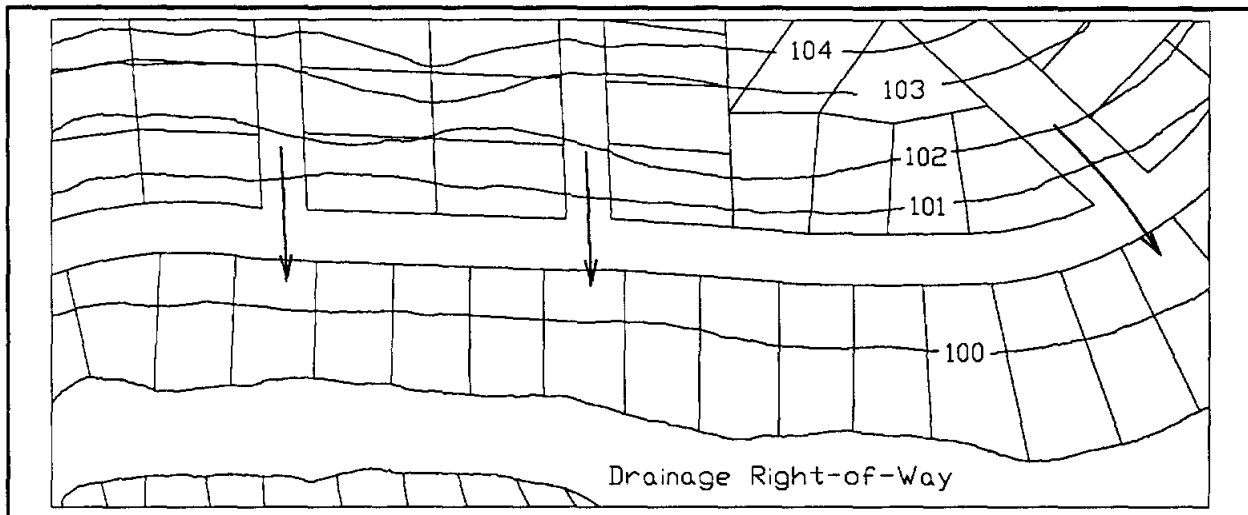

FIGURE 5.11 Undesirable Overland Flow at Street Intersections

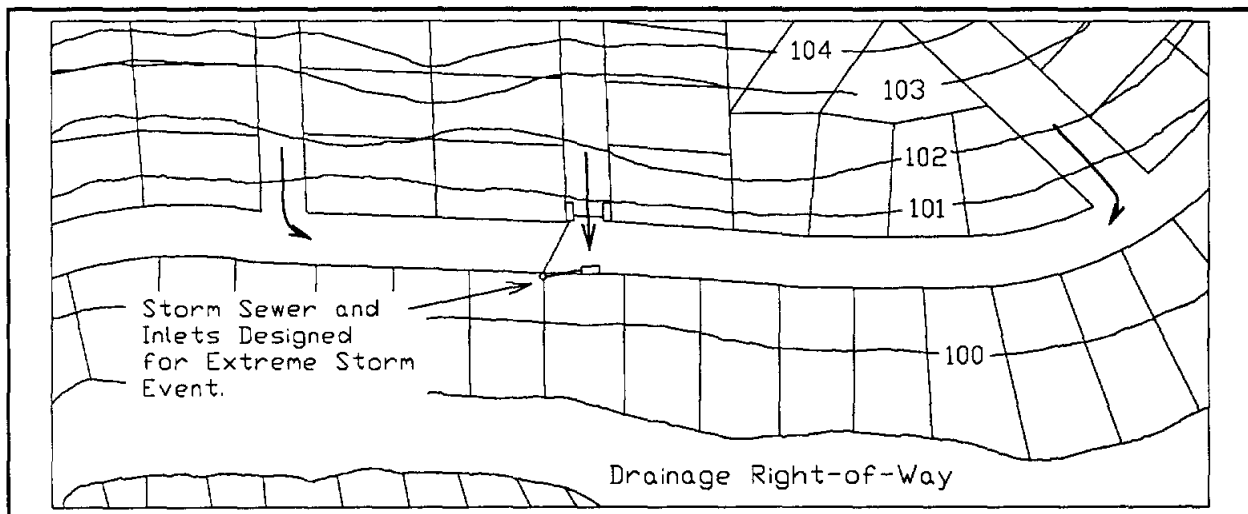

FIGURE 5.12 Acceptable Overland Flow at Street Intersections

5.3.2 Conveyance of Surface Flow to Primary Channels

Once it has been determined that ponding levels are excessive and where the collective sheet flow is going to go, provisions must be made to get the overflows into the appropriate drainage channel. This may be done through the use of additional pipe capacity and inlets or by using a surface swale. An underground conveyance system can be included in the storm sewer construction and maintenance program with minimal cost increase. Also, landowners are less likely to disturb an underground pipe than a surface swale. However, the surface swale will function for a wider range of flow conditions than the pipe system.

If surface swales are used, they should be concrete-lined to reduce the possibility of adjacent landowners disturbing them. The surface flow conveyance system shall be contained within an easement dedicated to the County. The easement shall be of sufficient width to operate and maintain the system.

Since a surface swale system would act only under emergency conditions and would not function under normal circumstances, all precautions must be taken to insure that the relief system will function when needed. The recommended design procedure for sizing pipe outfall structures for sheet flow conveyance is presented in SECTION 5.3.3 Roadside Ditch Drainage. The design procedure recommended for sizing of the surface swale is similar to the procedure for the pipe outfall as described in SECTION 5.3.3 Roadside Ditch Drainage. First, the appropriate values from steps one and two are computed, then the required swale cross-section is determined by normal depth calculations, sizing the swale such that an acceptable water surface is achieved.

5.3.3 Roadside Ditch Drainage

Under certain conditions, roadside ditch drainage is acceptable as an alternative to curb-and-gutter systems. However, a similar potential for flooding exists when flow in roadside ditches exceeds capacity. Provisions must be made to assure that the amount of water ponded behind an elevated roadway does not reach damaging levels. (See Figure 6.3 for typical roadside ditch interceptor drain detail).

Preliminary approval for the use of roadside ditch systems must be obtained from the Montgomery County Drainage Administrator prior to the submittal of contour and drainage area maps, and hydrologic and hydraulic calculations.

The following requirements taken from the *General Design Requirements for Sanitary Sewers, Storm Sewers, Water Lines and Paving* [City of Houston, 1983] must also be met in the design of roadside ditch systems in Montgomery County:

- 1) **Design Flow:** The design flow shall be determined based on the projected land use and the rainfall-runoff curves from Figure 5.4.
- 2) **Side Slope:** Minimum acceptable ditch section shall have a side slope no steeper than 3 horizontal to 1 vertical.
- 3) **Bottom Width:** The minimum bottom width for roadside ditches shall be two feet.
- 4) **Manning Coefficient:** The "n" coefficient for the ditch calculations shall be a minimum of 0.040. All values must be justified.
- 5) **Minimum Grade:** The minimum grade or slope of the ditches shall be 0.10%.
- 6) **Hydraulic Computations:** Hydraulic design computations must be submitted for each drainage ditch system.
- 7) **Freeboard:** The computed water surface of the ditches shall be a minimum of 0.5 foot below natural ground elevations along the street right-of-way lines.
- 8) **Erosion Control:** The entire ditch must be revegetated immediately after construction to minimize erosion. Erosion control methods shall be utilized where velocities of flow are calculated to be greater than five feet per second or where soil conditions dictate their need.
- 9) **Depth:** The minimum depth of the ditches shall be 18 inches and the maximum depth shall be 4 feet.

5.3.4 Extreme Event Storm Sewer Design

This section outlines the procedure recommended for designing an underground pipe system to convey overflows to a primary drainage channel. Because the majority of subdivisions in Montgomery County are designed with curb-and-gutter streets, modification of the last storm sewer reach is generally all that is necessary to handle the overflow.

The recommended procedure is given below along with an example based on the drainage system presented in Figure 5.3.

- 1) **Peak Flow Rate:** Determine the 100-year peak flow at the point of concentration from all existing and future contributing drainage areas for 100% development conditions. In the example, the contributing drainage area is 40 acres and the 100-year discharge is 147 cfs.
- 2) **Starting Elevation:** Determine the 25-year frequency water-surface elevation in the drainage channel at the pipe outfall point. Based on a 25-year backwater profile, the water surface elevation in the channel for the example is 97.0 feet.
- 3) **Compute Available Head:** Determine the maximum energy head, H , available between the outfall point and ponding area by subtracting the maximum allowable ponding elevation in the ponding area from the channel's 25-year water surface elevation. With a slab elevation of 101.5 feet and a top of curb and natural ground elevation of 100.0 feet in this example, the maximum allowable ponding elevation is the lowest of the following: 1) one foot over natural ground; 2) one foot over the top of curb; or 3) one foot below the lowest floor elevation. In this case, the maximum elevation is controlled by the lowest floor elevation and is 100.5 feet. There are 3.5 feet of head available (H).
- 4) **Compute Pipe Loss:** Establish a size of the storm sewer pipe and compute the head loss using the following equation:

$$H_p = 4.66 \frac{Q^2 n^2 L}{D^{163}} \quad \text{Equation 5.3}$$

in which:

H_p = head loss in feet

Q = 100-year discharge in cubic feet per second

n = Manning's "n" value

D = diameter of pipe in feet

L = length of pipe in feet

For this example, 65 linear feet of 60-inch corrugated metal pipe (CMP) with a Manning's n value of 0.024 and 120 linear feet of 60-inch reinforced concrete pipe (RCP) with a Manning's "n" value of 0.013 is selected. The head loss is as follows:

$$HL_p = 4.66 \frac{Q^2 (n_{CMP}^2 L_{CMP} + n_{RCP}^2 L_{RCP})}{D^{163}} = 4.66 \frac{(147)^2 [(0.024)^2 (65) + (0.013)^2 (120)]}{5^{163}} = 1.09 \text{ ft}$$

- 5) **Compute Lead Head Loss:** Compute the head loss through the leads, h_1 , using Equation 5.3. Experience has shown that 24-inch diameter leads generally cause excessive head loss. 30-inch diameter leads are satisfactory in most cases, while 36-inch leads are too large for the most common street inlets type "B-B" and "C-1." Therefore, the 30-inch diameter is selected. Estimate the percentage of 100-year runoff flowing through each lead. Assume the 147 cfs to be divided between three leads as follows:
 - Lead 1: 20-foot lead with a flow of 56 cfs.
 - Lead 2: 20-foot lead with a flow of 56 cfs.
 - Lead 3: 45-foot lead with a flow of 37 cfs.

$$HL_1 = 4.66 \frac{Q^2 n^2 L}{D^{163}} = 4.66 \frac{(56)^2 (0.013)^2 (20)}{2.5^{163}} = 0.37 \text{ ft}$$

$$HL_2 = HL_1$$

$$HL_3 = 4.66 \frac{(37)^2 (0.013)^2 (45)}{2.5^{1.63}} = 0.37 \text{ ft}$$

- 6) **Compute Inlet Head:** Determine the energy head available at each inlet using the equation:

$$H_i = H - H_p - HL \quad \text{Equation 5.4}$$

If H_i is negative, the hydraulic grade line is above the maximum ponding elevation. Increase the capacity of the system and repeat steps 4, 5, and 6. If H_i is positive, check the elevation of the hydraulic grade line relative to the maximum ponding elevation. For grade lines above the gutter line, use H_i as the energy head on the inlet; otherwise, make the value of H_i equal to the maximum ponding elevation minus the gutter elevation. For this example, assume the hydraulic grade line is above the gutter elevation. Since the head loss through the three leads in the example are similar, the available head at each inlet is:

$$H_i = 3.5 - 1.1 - 0.37 = 2.03$$

- 7) **Determine Inlet Type:** Determine the type of inlets required to handle the portion of the 100-year flow reaching the ponding area. The flow through the inlet(s) must be equal to or greater than the flows estimated in Step 5 for each lead. Use the following orifice equation to compute the flow into each inlet.

$$Q = CA\sqrt{2gH_i} \quad \text{Equation 5.5}$$

in which:

Q = discharge in cubic feet per second.

C = orifice coefficient (0.8 for inlets).

A = area of inlet opening. (Type "B-B" 2.14 square feet and Type "C-1" 6.50 square feet.)

g = acceleration of gravity (32.2 ft/sec²)

H_i = as defined in Step 6.

Type "C-1" inlets are selected for Inlet 1 and Inlet 2 and Type "B-B" inlets are selected for Inlet 3 across the street.

$$Q_{C-1} = 0.8(6.50)\sqrt{(64.4)(2.0)} = 59 \text{ cfs}$$

$$2Q_{B-B} = 2(0.8)(2.14)\sqrt{(64.4)(2.0)} = 38 \text{ cfs}$$

Thus, a Type "C-1" inlet at Inlet 1, a Type "C-1" inlet at Inlet 2, and two Type "B-B" inlets at Inlet 3 will convey the 100-year sheet flow to the channel with the energy head available. If this inlet choice is adequate, the design is complete.

- 8) **Repeat Analysis if Necessary:** Repeat Steps 4 through 7 until the combination of storm sewer pipe, leads, and inlets adequately conveys the 100-year sheet flow to the channel with the energy head available, and is the most economical.

5.3.5 Off-Site Overland Flow

Sheet flow from undeveloped areas into an existing or a proposed subdivision can create a localized flood hazard by overloading street inlets and/or flooding individual lots. Any drainage plan for a proposed subdivision submitted for review and approval by the Montgomery County Drainage Administrator must address the drainage of all adjacent lands, both under undeveloped and fully developed conditions. A plan which may be adequate under conditions of ultimate development

can be severely deficient during intermediate conditions of development due to sheet flow from adjacent undeveloped land. Provisions must be made to divert 100-year sheet flows to a channel system or to the secondary street and storm sewer system.

Redirection of the sheet flow can usually be achieved through the use of drainage swales located in temporary drainage easements along the periphery of the subdivision. As the adjacent area develops to the point at which the street system can effectively handle the sheet flow condition, the temporary drainage swales and easements may be abandoned. The drainage swales should be relatively shallow, with the excavation spoiled continuously along the subdivision side of the swale to prevent flow from overrunning the swale. The swale should have sufficient grade to avoid standing water, but not enough to create erosion problems. Generally, a minimum grade of 0.10% should be maintained with the maximum grade strongly dependent on local soil conditions.

Such temporary drainage swales may be directed to inlets in the storm sewer system or, preferably, to the appropriate primary outfall channel. If an undeveloped area is to be drained to a storm sewer, additional inlet and storm sewer capacity must be provided to prevent prolonged street ponding in the subdivision resulting from flow from the undeveloped area. Provisions for this flow must also be included in the design of the street drainage overflow system. The design of temporary drainage swales directed to Montgomery County drainage channels must include adequate provisions to drop the flow into the channel through an approved structure in order to avoid excessive erosion of the channel banks.

Outfalling the temporary swale into the backslope drainage system for the channel is unacceptable because the backslope drainage interceptor structures are not adequate to convey flow from an off-site swale. A typical approved structure is shown in Figure 6.3, with the exception of the pipe dimension. The pipe must be sized to handle the 100-year flow from the off-site area.

SECTION 6 EROSION AND SEDIMENT CONTROL

This section provides recommended criteria for control of channel erosion and siltation. The primary objective is to maintain the capacity and stability of open channels. The erosion potential must be addressed in all designs of open channels or hydraulic structures.

6.1 SOIL CONDITIONS

Two basic considerations which must be analyzed are the flow characteristics in terms of velocity and turbulence, and the properties of the affected soils. For all new channels and for major channel improvements, a soils report which addresses erosion and slope stability must be submitted. Erosion protection should be installed in areas where recommended by the geotechnical engineer. For minor channel alterations, check with the Montgomery County Drainage Administrator to determine whether erosion control measures are necessary.

Substantial amounts of sands and silts exist in Montgomery County. Naturally, more extensive erosion protection measures are needed for sands and silts than for clays. Particularly difficult stability problems exist where a sand or silt seam overlaid by clay is located near the toe of a channel slope.

6.2 CHANNEL EROSION

Channel erosion is generally caused by excessive velocities in the channel; by flow over the banks of the channel; or by secondary flows at junctions, bends, and transitions. Each of these sources of erosion can be minimized if erosion protection measures are included in the design and construction of the channel and its appurtenances. Adequate grass cover or a structural lining in the channel often can minimize problems due to excessive velocities and secondary flow. Backslope drainage systems can intercept flow within the right-of-way to prevent overbank flow and erosion.

6.2.1 Grass Establishment

A good grass cover must be established on all areas within the right-of-way (except the channel bottom) disturbed by channel improvements or by any type of construction. An adequate grass stand on the banks helps stabilize the channel and minimizes erosion caused by overbank flow and high velocities in the channel.

Establishing a good grass cover requires preparing the seedbed, seeding properly, keeping the seed in place, fertilizing, and watering regularly. As a minimum requirement, the Harris County Flood Control District specification entitled *Hydro Mulch Seeding* must be followed on all reseeding operations. Other methods of retaining the soil and seeds such as asphalt mulch, jute mesh, or paper mesh may be used with prior approval from the Montgomery County Drainage Administrator. Solid sodding or sprigging are two recommended methods in areas where hydro mulch may not be successful.

6.2.2 Minimum Erosion Protection for Confluences

Figure 6.1 presents the minimum requirements for determining when erosion protection or channel lining are necessary given the angle of the confluence of two channels. A healthy cover of grass must also be established from the top edge of the lining to the top of the channel bank. The top edge of the lining shall extend to the 25-year water surface elevation.

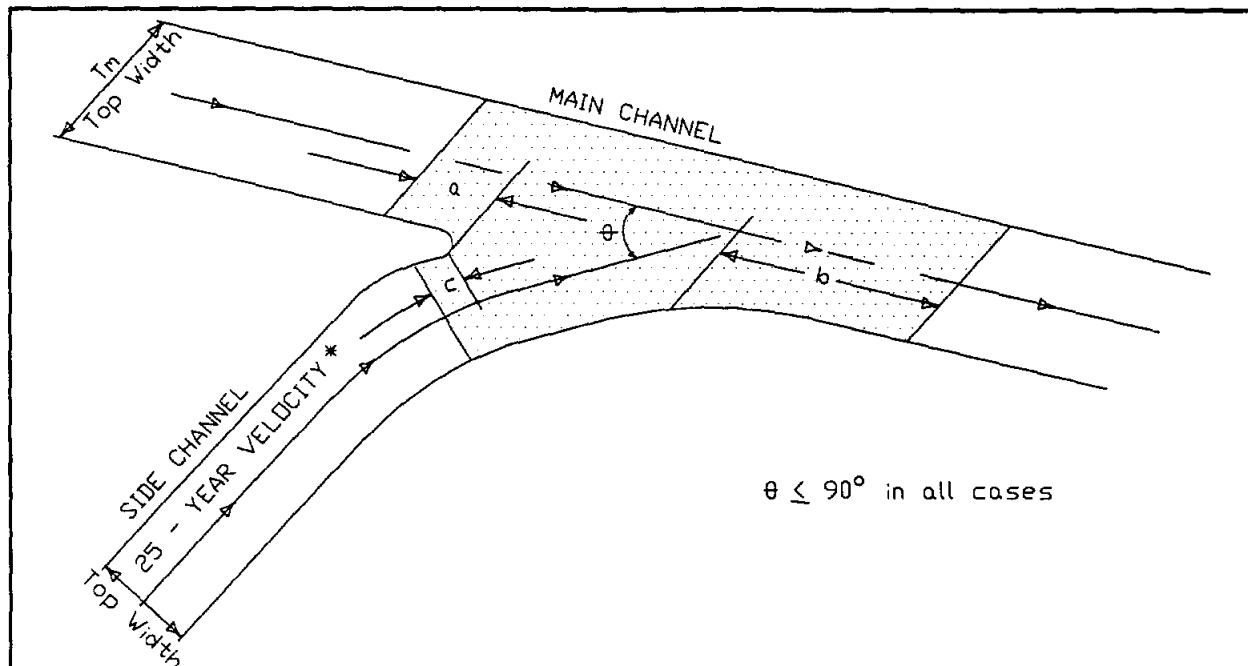

FIGURE 6.1 Typical Channel Confluence

TABLE 6.1 Minimum Erosion Protection for Channel Confluences

25-Year Velocity in Side Channel (fps)	Angle of Intersection θ	
	15 to 45 degrees	45 to 90 degrees
4 or more	Protection Required	Protection Required
2 to 4	No Protection Required	Protection Required
2 or less	No Protection Required	No Protection Required

Source: [HCFCF, 1984] Note: See Figure 6.1 for illustration of θ .

TABLE 6.2 Minimum Extent of Erosion Protection for Channel Confluences

Location	Minimum Distance
a	20 ft
b	larger of 50 ft or $0.75T_m / \tan \theta$
c	20 ft

Source: [HCFCF, 1984] Note: See Figure 6.2 for illustration of a , b , R , and T .

6.2.3 Minimum Erosion Protection Requirements for Bends

Slope protection is required for channel bends with a radius of curvature measured from the center-line of less than three times the top width of the ultimate channel. When required, erosion protection must extend along the outside bank of the bend and at least 20 feet downstream of it. Additional protection on the channel bottom and inside bank, or beyond 20 feet downstream, will be required if maximum allowable velocities are exceeded. See Table 6.4 for allowable 25-year flow velocities. Figure 6.2 illustrates the minimum erosion protection requirements for channel bends.

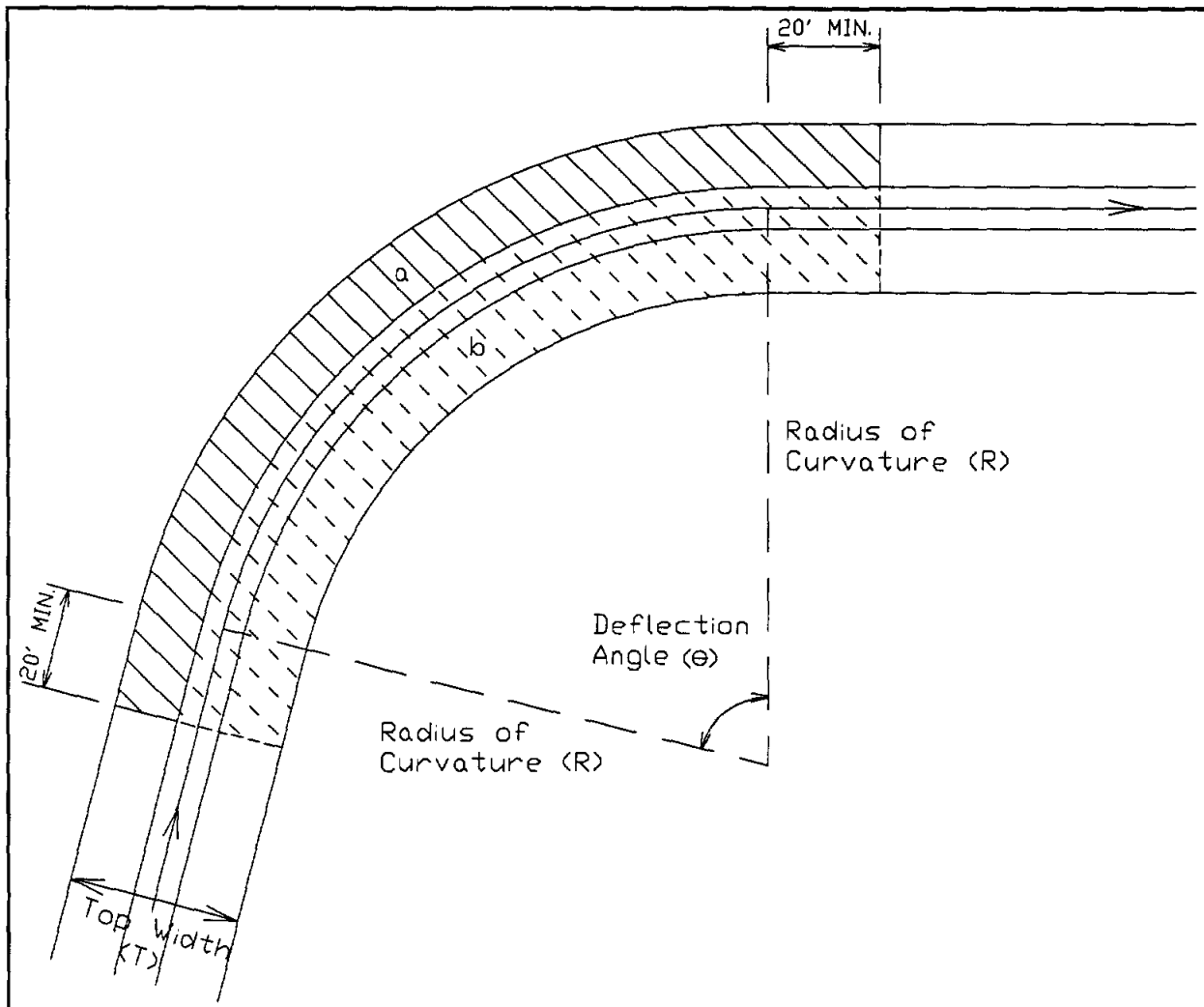

FIGURE 6.2 Typical Channel Bend

TABLE 6.3 Minimum Erosion Protection for Channel Bends

Location	Erosion Protection Requirements
a	Slope protection required if $R/T \leq 3.0$, or if 25-year flow velocities exceed allowable values given in Table 6.4
b	Slope protection required if 25-year flow velocities exceed allowable values given in Table 6.4

Source: [HCFC, 1984] Note: See Figure 6.2 for illustration of a , b , R , and T .

TABLE 6.4 Allowable 25-Year Flow Velocities for Channel Design

Channel Description	Average Velocity (Feet Per Second)	Maximum Velocity (Feet Per Second)
Grass Lined: Predominantly Clay Soil	3.0	5.0
Grass Lined: Predominantly Sand Soil	2.0	4.0
Rip-rap Lined	5.0	8.0
Concrete Lined	6.0	10.0

Source: [HCFC, 1984]

6.2.4 Minimum Erosion Protection for Culverts

In areas where outlet velocities exceed five feet per second into a grass-lined channel, channel lining or an energy dissipation structure will be required.

6.2.5 Structural Measures for Erosion and Sediment Control

In areas of the channel where the maximum velocities given in Table 6.4 are exceeded, or where determined by minimum erosion protection requirements, a structural erosion protection such as cellular concrete articulated mats, concrete slope paving, rip-rap, revetment mats, gabions, etc. must be installed. The slope protection must at least extend up the banks to the 25-year flood level.

6.2.5.1 Rip-Rap

Rip-rap is broken concrete rubble or well-rounded stone. The use of rip-rap is encouraged because of its proven past performance, its flexibility, and its high Manning's "n" value (approximately 0.04), which reduces channel velocities. A discussion of rip-rap design can be found in Corps EM 1110-2-1601 [USACE, 1970].

Minimum requirements and criteria for rip-rap installation in Montgomery County have been taken from the *Criteria Manual for Design of Flood Control and Drainage Facilities in Harris County, Texas*, [HCFCD, 1984] and are as follows:

- 1) **Mat Thickness:** Minimum mat thickness is 18 inches. Thickness of layer at toe of slope should be increased below the anticipated scour depth.
- 2) **Block Description:** Use evenly graded, 80-pound to 150-pound blocks. Minimum 6-inch thickness per block. No exposed steel in broken concrete rubble.
- 3) **Side Slope:** Maximum steepness of the side slope is 2 (horizontal) to 1 (vertical).
- 4) **Bedding:** Gravel bedding or filter fabric is required for extensive installations or where warranted by soil conditions.

6.2.5.2 Concrete Slope Paving

For concrete slope paving in the channel, minimum structural requirements are presented in SECTION 3. In most cases, a minimum 10-foot rip-rap protection blanket located on the downstream side of the paving will be necessary to protect concrete toe walls. Minimum requirements for partially or fully concrete-lined channels are presented in SECTION 3.2.14.

6.2.5.3 Straight Drop Spillway

The straight drop spillway is commonly installed in drainage channels to adjust channel gradients which are too steep for design conditions. This type of spillway design is based on the hydraulics of the aerated free-falling nappe. Figure 6.3 illustrates the configuration of a typical straight drop spillway constructed of steel sheet piling.

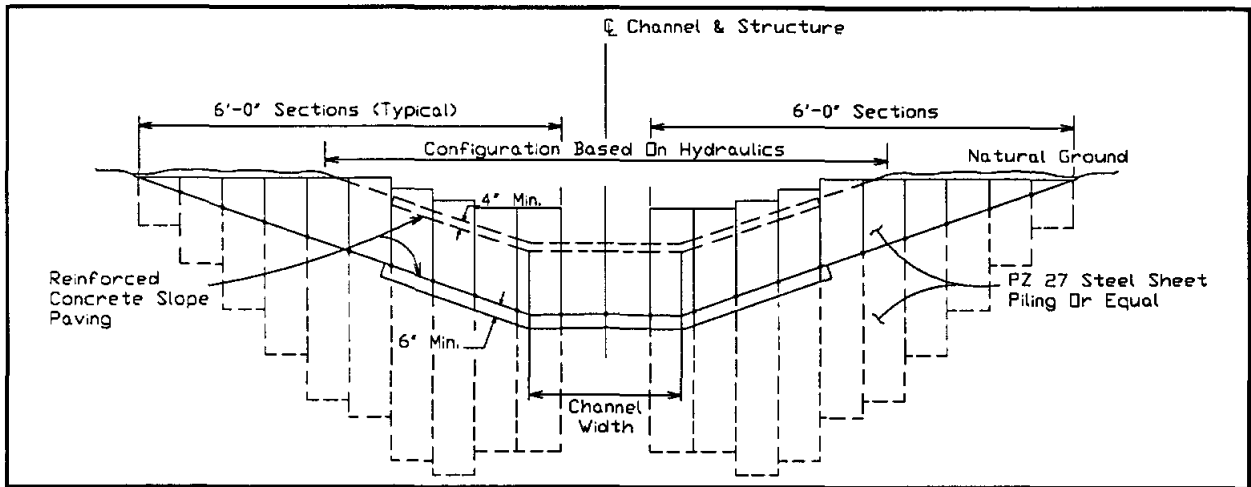

FIGURE 6.3 Cross-Section of Typical Straight Drop Spillway

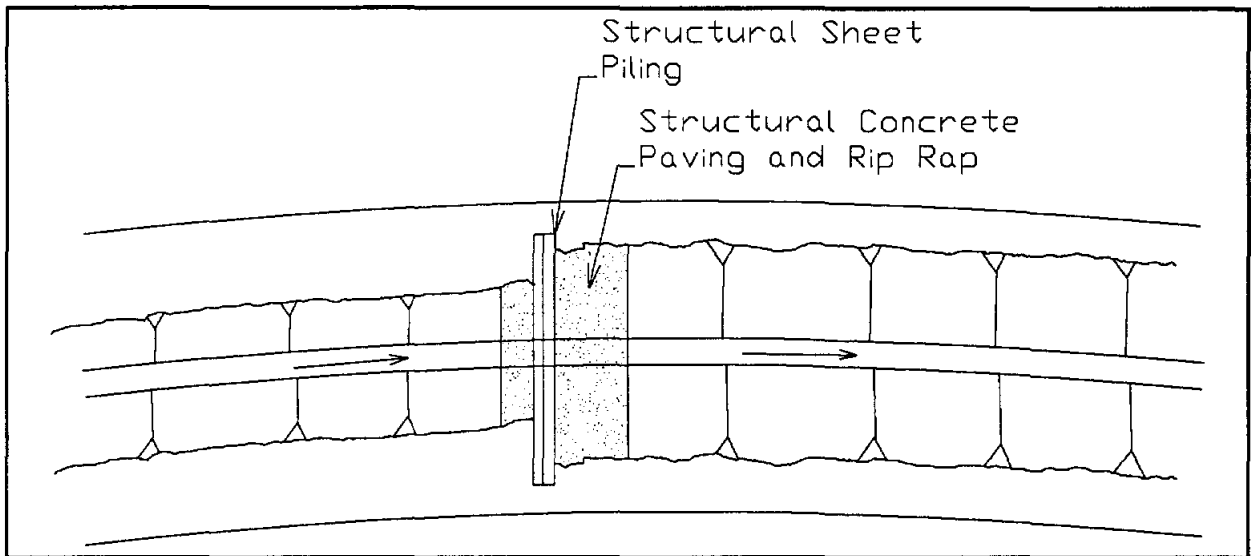

FIGURE 6.4 Plan View of Typical Straight Drop Spillway

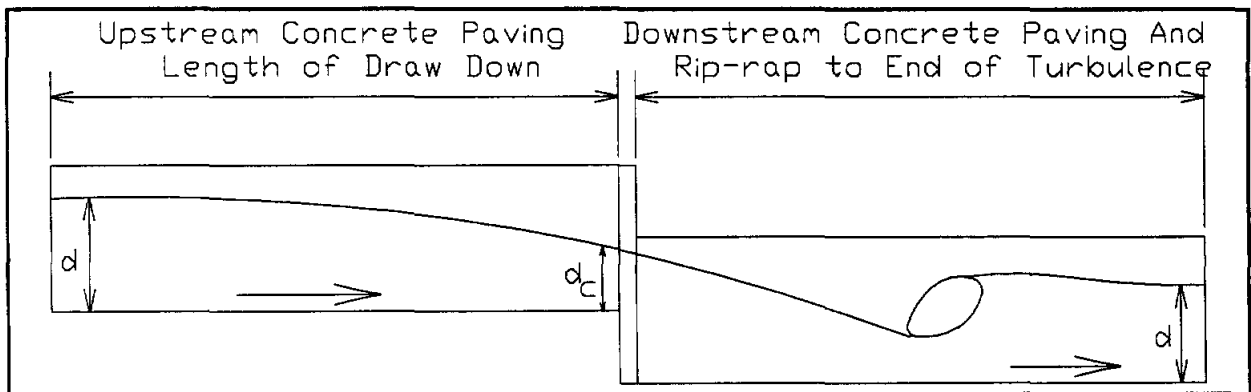

FIGURE 6.5 Profile View of Typical Straight Drop Spillway

6.2.5.3.1 Hydraulics of Straight-Drop Spillways

Figure 6.6 illustrates the flow geometry of a straight drop spillway. The aerated free falling nappe in a straight drop spillway will reverse its curvature and turn smoothly into super-critical flow on the apron. The flow geometry at straight drop spillways can be described by functions of the **drop number**, D , which is defined as:

$$D = \frac{q^2}{gh^3} \quad \text{Equation 6.1}$$

in which:

q is the discharge per unit width of the crest of overfall.

g is the acceleration of gravity (32.2 ft/sec²).

h is the height of the drop.

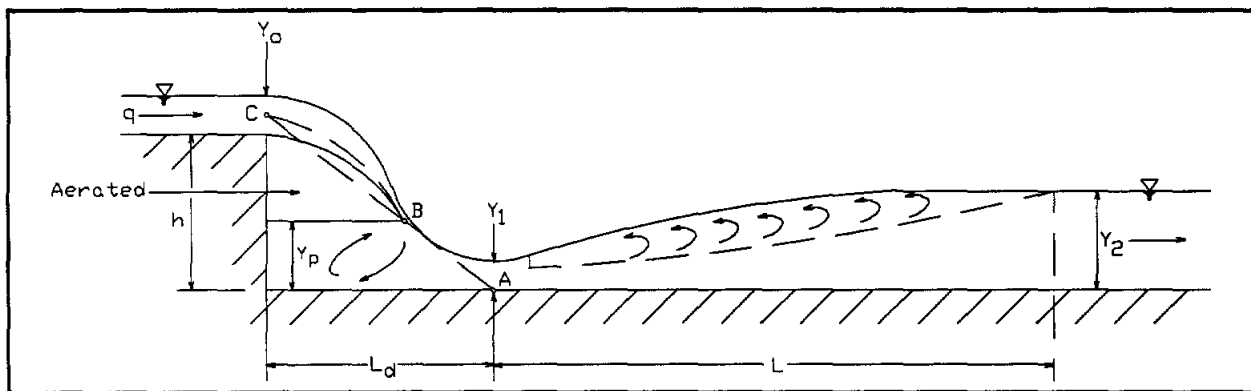

FIGURE 6.6 Flow Geometry of Straight Drop Spillway

The functions of the drop number used to describe the flow geometry are:

$$\frac{L_d}{h} = 4.30D^{0.27} \quad \text{Equation 6.2}$$

$$\frac{Y_p}{h} = 1.00D^{0.22} \quad \text{Equation 6.3}$$

$$\frac{Y_1}{h} = 0.54D^{0.425} \quad \text{Equation 6.4}$$

$$\frac{Y_2}{h} = 1.66D^{0.27} \quad \text{Equation 6.5}$$

in which:

L_d = drop length, or distance from the drop to the position of the depth Y_1

Y_p = pool depth under the nappe

Y_1 = depth at the toe of the nappe or the beginning of the hydraulic jump

Y_2 = the tailwater depth sequent to Y_1 .

If the tailwater depth is less than Y_2 , the hydraulic jump will recede downstream. If the tailwater depth is greater than Y_2 , the jump will be submerged. As the tailwater rises, the spillway crest may finally be submerged. The spillway will still be effective if the submergence does not reach the control depth on the spillway crest.

These relationships consider the flow at the straight drop spillway to be a two-dimensional flow that practically corresponds to the flow near the center of a wide channel. That is, the spillway crest is assumed to be the same width as the channel. The design of the approach channel should analyze carefully the effects of any end contractions which may cause the ends of the nappe to land beyond the basin apron and the side walls. The flow geometry at the drop depends on the discharge per unit width, q , the height of drop, h , and the depth of uniform flow in the channel upstream and downstream from the drop structure. Aeration of the nappe is important to the proper functioning of the drop and the structural stability of the drop structure.

Experimental studies have demonstrated that the depth, Y_0 , at the brink of the drop is approximately 70 percent of critical depth, and that critical depth actually occurs a distance of about four times the critical depth upstream from the brink. For example, a typical channel section carrying 3,000 cfs has a critical depth of 6 to 8 feet. If the drop structure opening was designed with the same dimensions as the channel, critical depth could occur 30 to 40 feet upstream of the brink. Due to this draw down, velocities at critical depth and upstream of critical depth would be in excess of acceptable velocities for grass-lined channels in Montgomery County.

In order to avoid excessive drawdown of the upstream water surface and resulting high velocity, the opening in the structure must have less cross-sectional area than the channel. Critical depth is a function of the discharge rate and geometry. By reducing the area of the opening, critical depth will be forced to occur at the structure rather than in the upstream channel, thereby creating a backwater condition. The structure opening can be designed from the bottom up using a range of flows in an iterative process. Special attention must be given to the energy grade line during design. An analysis of the water-surface drawdown should be performed to determine the limits of erosion protection required upstream of the structure.

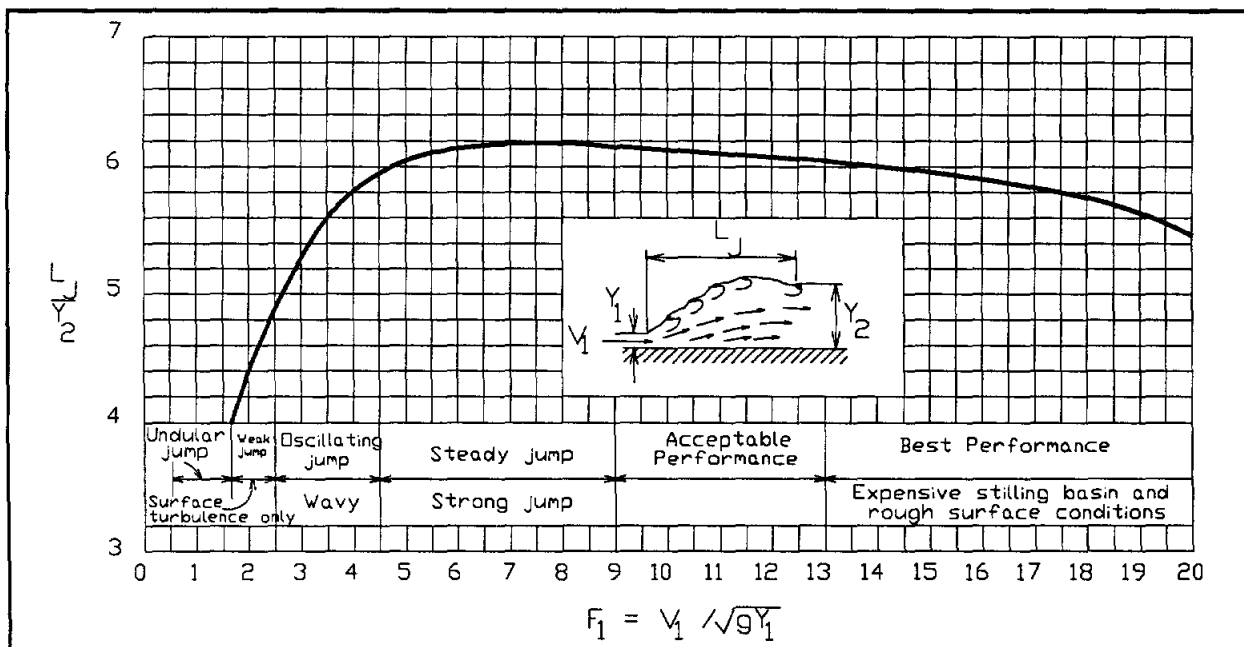

FIGURE 6.7 Length of Hydraulic Jumps

The length of the downstream hydraulic jump cannot be easily determined by theory, but it has been investigated experimentally. Various technical references give experimental results for jump lengths. Figure 6.7 illustrates a curve based on data and recommendations of the U.S. Bureau of Reclamation [USBUREC, 1984]. This curve allows the determination of jump lengths in rectangular channels. In the absence of more extensive data, this curve may be used to approximate jump lengths in trapezoidal channels.

6.2.5.3.2 Design Procedure for Straight Drop Spillways

The following procedure may be used to design straight drop spillways:

- 1) **Design Flow Rate:** Determine the peak 100-year flow rate at the drop structure. This may be accomplished through a HEC-1 analysis or by using drainage area versus peak flow rate curves for the particular watershed in which the stream under consideration is located.
- 2) **Channel Hydraulics:** Compute the normal depth (D_N), flow velocity (V_N), and energy head (H_N) in the channel upstream of the structure for 20% of the peak 100-year flow rate using Manning's Equation.
- 3) **Determine Lowest Opening Width:** Design the lowest opening of the drop for 20% of the peak 100-year flow using the following equations:

$$d_c = \frac{2}{3}H_N \quad \text{Equation 6.6}$$

$$V_c = \sqrt{d_c g} \quad \text{Equation 6.7}$$

$$A = \frac{Q}{V_c} \quad \text{Equation 6.8}$$

$$W_1 = \frac{A}{d_c} \quad \text{Equation 6.9}$$

in which:

d_c = approximate depth of critical flow

V_c = approximate velocity of critical flow

g = acceleration due to gravity (32.2 ft/sec/sec)

A = area of flow

W_1 = width of single opening to produce necessary area for critical flow.

- 4) **Determine Other Opening Widths:** Determine opening widths for several percentages of the 100-year flow by completing steps 2 and 3 for each flow rate. Use the following equation to determine the widths of multiple openings:

$$W_i = \frac{A_i - A_{i-1}}{d_{ci} - d_{ci-1}} \quad \text{Equation 6.10}$$

in which:

W_i = width of successive openings in drop structure, when more than one are used

d_{ci} = depth of critical flow for successive openings in drop structure

A_i = area of successive openings in drop structure

- 5) **Design Openings:** Use the results of steps 2 through 4 to determine the dimensions of a number of openings (usually from 2 to 5) in the sheet piling which will yield a configuration similar to that indicated by those results.
- 6) **Compute Profiles:** Use HEC-2 to compute water surface profiles in the channel for several different flows. Adjust the drop structure configuration as necessary to yield the desired water surface elevations and velocities upstream of the drop.
- 7) **Upstream Slope Protection:** Examine the HEC-2 results to determine the required length of upstream slope protection. The slope protection should extend far enough upstream to reach a point where the flow velocity is below the accepted maximum for all flows (see SECTION 3). The minimum length of upstream protection is 40 feet. At least 20 feet of the total length should be rip-rap, with the balance being concrete slope paving. The rip-rap should be placed upstream of the concrete paving.
- 8) **Downstream Slope Protection:** Compute the drop number and functions of the drop number using equations 6.1 through 6.5 (all parameters are defined on Figure 6.6). Using the depth at the toe of the nappe (Y_1), compute the area at the toe of nappe (A_1) and the corresponding velocity (V_1). Then, compute the Froude number (F_1) using the formula

$$F_1 = \frac{V_1}{\sqrt{gY_1}} \quad \text{Equation 6.11}$$

Using the Froude number F_1 to determine a value of L_j/Y_2 from the curve on Figure 6.7 illustrating the relationship between these parameters, compute the jump length L_j using the values of L_j/Y_2 and Y_2 which have already been determined. Compute the total length of slope protection required by combining the drop length L_D with the jump length L_j .

$$L_{sp} = L_D + L_j \quad \text{Equation 6.12}$$

Repeat this procedure for several percentages of the peak 100-year flow rate. Choose the maximum value of L_{sp} as the required length of slope protection.

- 9) **Downstream Rip-rap:** Break the total length of downstream slope protection into a length of concrete slope paving and a length of rip-rap. The minimum total length of slope protection downstream of a straight drop structure is 50 feet, with a minimum of 20 feet of rip-rap included in the total. The rip-rap should be placed downstream of the slope paving on the downstream side of the drop structure.

6.2.5.3.3 Example of Straight Drop Spillway Design

This section provides an example of the procedure recommended for designing a straight drop spillway. The procedure below is based on the channel and drop structure shown in Exhibits 6.3 and 6.4. For this example, a 5-foot vertical drop is to be accommodated in a channel with upstream bottom width = 15 feet, side slopes = 3:1 (H:V), channel invert slope $S = 0.08\%$, and Manning's n-Value = 0.04.

- 1) **Design Flow Rate:** Determine the 100-year frequency flow to the design point from all existing and future contributing drainage areas for 100% development. For this example the drainage area is 3,500 acres, and the 100-year flow is 2,000 cfs. (See SECTION 2 for determination of flow.)
- 2) **Channel Hydraulics:** Determine the normal depth, D_N , normal velocity, V_N , and energy head, H_N , in the channel upstream of the structure for various percentages of the 100-year flow using Manning's Equation:

$$Q = \frac{1.486}{n} AR^{2/3} \sqrt{S} \quad \text{Equation 6.13}$$

Rearranging and solving for $AR^{2/3}$ yields:

$$AR^{2/3} = \frac{nQ}{1.486\sqrt{S}}$$

For 20% of the 100-year flow rate,

$$AR^{2/3} = \frac{400 \times 0.04}{1.486 \times \sqrt{0.0008}} = 380.7$$

Determine the normal depth, D_N , using hydraulic tables, graphs, or by trial and error using equations for A and R. For this example, $D_N = 5.38$ ft, and the corresponding area, $A = 168$ sq ft. After determining normal depth, the normal velocity, V_N is determined using the following equation:

$$V_N = \frac{Q}{A} = \frac{400}{168} = 2.38$$

The energy head at normal depth, H_N , is computed as follows:

$$H_N = D_N + \alpha \frac{V_N^2}{2g} = 5.38 + 1.1 \times \frac{(2.38)^2}{2 \times 32.2} = 5.47$$

In this equation, α = the energy coefficient. For trapezoidal channels, $\alpha = 1.1$.

Table 6.5 lists the computed values for Normal Depth, Normal Velocity, and Velocity Head for various flow rates up through the 100-year flow rate.

TABLE 6.5 Example of Computed Hydraulic Values

Q (%)	Q (cfs)	$AR^{2/3}$	D_N (ft)	V_N (fps)	H_N (ft)
20%	400	380.7	5.38	2.38	5.48
40%	800	761.4	7.46	2.86	7.60
60%	1,200	1,142.0	8.99	3.18	9.16
80%	1,600	1,522.7	10.23	3.42	10.43
100%	2,000	1,903.4	11.29	3.62	11.51

- 3) **Determine Lowest Opening Width:** Design an opening of the straight drop spillway for 20% of the 100-year flow, using Equations 6.6 through 6.9. Note: The equations for critical depth and critical velocity are approximations which simplify initial calculations. These results will be checked later.

For $Q_{20\%} = 400$ cfs, $H_n = 5.48$ ft. Using Equation 6.6, $d_c = 5.48 \times 2/3 = 3.65$ ft. Equation 6.7 is used to determine $V_c = \sqrt{3.65 \times 32.2} = 10.84$ fps. Equation 6.8 is applied to compute the Area, $A = 400/10.84 = 36.9$ sq ft. Therefore, the width of the lowest opening, $W_1 = 36.9/3.65 = 10.1$ ft.

- 4) **Determine Other Opening Widths:** Similar computations are performed for 40%, 60%, 80%, and 100% of the 100-year peak flow rate. Equation 6.10 is used to compute successive widths of multiple openings. Table 6.6 lists the computed widths for each flow rate.

TABLE 6.6 Example of Computed Opening Widths

Q (cfs)	H_N (ft)	d_c (ft)	V_c (fps)	A (ft ²)	W_1 (ft)	W_i (ft)
400	5.5	3.7	10.8	36.9	10.1	10.1
800	7.6	5.1	12.8	62.5	12.3	17.9
1,200	9.2	6.1	14.0	85.4	13.9	22.9
1,600	10.4	7.0	15.0	106.7	15.3	23.6
2,000	11.5	7.7	15.8	126.9	16.5	28.8

- 5) **Design Openings:** For more practical construction, the five opening widths listed in Table 6.6 are simplified to the three widths listed in Table 6.7.

TABLE 6.7 Example of Simplified Opening Widths

Depth (ft)	Width (ft)
4	10
7	22
9	28

- 6) **Compute Profiles:** As noted, the critical depth computed in Steps 3) and 4) above are based on an approximation. The critical depth for use in backwater calculations may be calculated by solving equation 6.14.

$$\alpha \frac{Q^2}{g} = \frac{A^3}{B} \quad \text{Equation 6.14}$$

in which:

Q = the flow in cfs

A = the actual area of drop structure opening at the trial depth

B = the top width of the opening at the trial depth

g = the acceleration due to gravity

α = energy coefficient

For a flow rate of 2,000 cfs, $\alpha Q^2/g = 1.1 \times (2000)^2 + 32.2 = 136,645 \text{ ft}^5$. By solving for A , the critical depth of 8.80 produces $(10 \times 4 + 22 \times 3 + 28 \times 1.80)^3 + 28 = 136,632 \text{ ft}^5$. Therefore, 8.80 ft is the beginning 100-year water surface elevation at the drop structure.

- 7) **Upstream Slope Protection:** Analyze the upstream water surface profiles and determine the point upstream of the drop structure where velocities fall below the maximum allowed as given in Table 6.4. A range of flow conditions should be checked. However, the 100-year flow generally results in the highest upstream velocities. Assume that Table 6.8 lists the results of a HEC-2 analysis of the channel upstream of the drop structure. These results are computed assuming a contraction loss coefficient of 0.6.

TABLE 6.8 Example HEC-2 Results for Upstream Channel

Upstream Channel Station (ft)	Water Surface Elevation (ft)	Energy Grade Elevation (ft)	Depth (ft)	Flow Velocity (fps)
0+00	108.8	111.59	8.8	12.78
0+20	112.9	113.14	12.88	3.8
0+40	113.38	113.51	13.36	2.71
10+00	113.75	113.74	12.78	2.93

It is apparent that the velocities are low enough such that there should be no erosion problem beyond 40 feet upstream. Therefore, the concrete slope protection should extend 20 feet upstream with 20 feet of rip-rap beyond that.

- 8) **Downstream Slope Protection:** The final consideration in the hydraulic design of the straight drop structure is the design of downstream slope protection. The length of slope protection is the sum of the drop length, L_D , and the length of the hydraulic jump, L_J . The greatest drop length, L_D , is determined using Equations 6.1 through 6.5. Table 6.9 lists the results.

TABLE 6.9 Example of Computed Drop Lengths

Q (cfs)	W (ft)	q (cfs/ft)	h (ft)	D	L_D (ft)
400	10	40.0	5.0	0.3972	16.75
800	22	36.4	9.0	0.0564	17.80
1,200	22	54.5	9.0	0.1265	22.14
1,600	22	72.7	9.0	0.2252	25.87
2,000	28	71.4	12.0	0.0916	27.06

The length of the hydraulic jump is determined using Figure 6.7. The jump is dependent on the Froude number, which is computed using Equation 6.11. The Froude number will be greatest for the 100-year flow:

$$Y_1 = 0.54D^{0.425}h = 0.54 \times (0.0916)^{0.425} \times 12.0 = 2.35 \text{ ft}$$

$$Y_2 = 1.66D^{0.27}h = 1.66 \times (0.0916)^{0.27} \times 12.0 = 10.44 \text{ ft}$$

The cross-sectional area at the jump may be computed using the following equation:

$$A = Y_1 \times \frac{W_T + W_B}{2} = 2.35 \times \frac{(15 + 6 \times 2.35) + 15}{2} = 51.8$$

in which:

W_T = top width of flow (feet)

W_B = bottom width of channel (feet)

The velocity at the jump, $V_1 = Q/A = 2000/51.8 = 38.6$ fps

Therefore, the Froude number may be computed using Equation 6.11:

$$F_1 = \frac{V_1}{\sqrt{gY_1}} = \frac{38.6}{\sqrt{32.2 \times 2.35}} = 4.44$$

According to Figure 6.7, $L_J/Y_2 = 5.9$. Therefore, the length of the hydraulic jump $L_J = L_J/Y_2 \times Y_2 = 5.9 \times 10.44 = 61.6$ ft. Total length of slope protection should then be $61.6 \text{ ft} + 27.1 \text{ ft} = 88.7$ ft, or about 90 feet downstream of the drop structure.

- 9) **Downstream Rip-Rap:** The slope protection should consist of 70 feet of 6-inch concrete slope paving and 20 feet of rip-rap.

6.2.5.4 Sloped Drop Structures

Sloped drop structures are recommended when the required drop elevation is small, generally from 1 to 4 feet. They tend to be the most economical and topographically versatile means to accomplish a drop. Sloped drops should be no steeper than 2:1 and no flatter than 4:1 (measured along the channel invert).

Sloped drops shall be constructed of concrete slope paving or of cellular concrete articulated mats. Rip-rap or appropriate alternate erosion protection shall be provided upstream and downstream of the drop.

When sub-critical flow approaches a drop, depth decreases and velocity increases as the flow nears critical depth. Accordingly, appropriate erosion protection must be provided sufficiently upstream such that flow velocities are not excessive in any unprotected reach of channel. The minimum recommended distance is 20 feet.

Downstream of the drop, the required length for protection is dependent on the length of the hydraulic jump. As a rough estimate the jump length may be assumed equal to $q/2$, one-half of the design flow per unit width of channel. The use of rip-rap or a combination of rip-rap and concrete slope paving is recommended downstream of the drop to force the jump closer to the drop. A minimum of 20 feet of rip-rap is required downstream of any slope paving used at a drop structure to help reduce velocities and protect the concrete toe. The minimum recommended length of slope paving downstream of a sloped drop is 40 feet.

6.2.5.5 Baffled Chutes

Baffled chutes are used in drainage ways when a relatively large change in elevation is necessary. The baffle blocks prevent undue acceleration of the flow as it passes down the chute. Baffled chutes are generally laid out on a 2:1 slope (no steeper) and can be designed to discharge up to 60 cfs per foot of channel width. The lower end of the chute is constructed to below stream bed level and backfilled as necessary, thereby minimizing degradation or scour of the stream bed. No tailwater or stilling basin is required, as velocities will remain moderate. Figure 6.8 illustrates a baffled chute.

The following simplified step-by-step procedure developed by the Bureau of Reclamation [US-BUREC, 1961] is recommended for the design of baffled chutes. Bureau of Reclamation Engineering Monograph No. 25 [USBUREC, 1984] contains an even more detailed discussion. A step-by-step design procedure is presented below:

- 1) **Design Discharge:** The baffled apron should be designed for the 100-year discharge, Q . The unit discharge $q = Q/W$ may be as high as 60 cubic feet per second per foot of chute width, W . Less severe flow conditions at the base of the chute exist for 35 cubic feet per second and a relatively mild condition occurs for unit discharges of 20 cubic feet per second and less.
- 2) **Entrance Velocity:** Entrance velocity, V_1 should be as low as practical. Ideal conditions exist when $V_1 = (gq)^{1/3} - 5$ (See Curve D, Figure 6.9). Flow Conditions are not acceptable when $V_1 = (gq)^{1/3}$ (See Curve C, Figure 6.9).
- 3) **Chute Design:** The vertical offset between the approach channel floor and the chute is used to create a stilling pool or desirable V_1 and will vary in individual installations; Figure 6.8 shows a typical approach pool. Use a short radius curve to provide a crest on the 2:1 sloping chute. Place the first row of baffle piers close to the top of the chute no more than 12 inches in elevation below the crest.

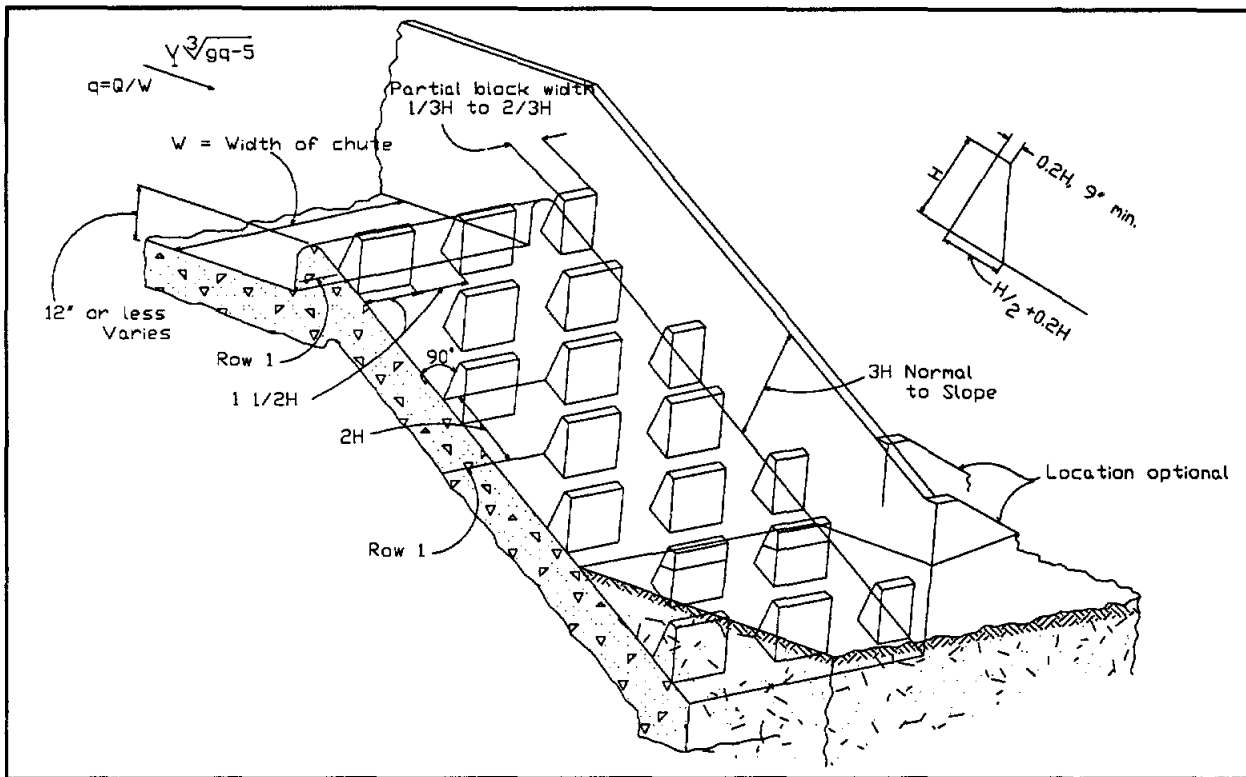

FIGURE 6.8 Typical Baffled Chute

- 4) **Baffle Height:** The baffle pier height, H , should be about $0.8D_c$ (see Curve B, Figure 6.9). The critical depth on the rectangular chute is $D_c = (q^2/g)^{1/3}$ (see Curve A, Figure 6.9). Baffle pier height is not a critical dimension but should not be less than recommended. The height maybe increased to $0.9D_c$ critical.
- 5) **Baffle Width:** Baffle pier widths and spaces should be equal, preferably about $1.5H$, but not less than H . Other baffle pier dimensions are not critical; suggested cross section is shown in Figure 6.8. Partial blocks, width $0.33H$ to $0.67H$, should be placed against the training walls in Rows 1, 3, 5, 7, etc., alternating with spaces of the same width in Rows 2, 4, 6, etc.
- 6) **Baffle Row Spacing:** The slope distance between rows of baffle piers should be $2H$, twice the baffle height H . When the baffle height is less than 3 feet, the row spacing may be greater than $2H$ but should not exceed 6 feet.
- 7) **Baffle Alignment:** The baffle piers are usually constructed with their upstream faces normal to the chute surface; however, piers with vertical faces may be used. Vertical face piers tend to produce more splash and less bed scour, but differences are not significant.
- 8) **Chute Length:** Four rows of baffle piers are generally required to establish full control of the flow, although fewer rows have operated successfully. Additional rows beyond the fourth maintain the control established above, and as many rows may be constructed as is necessary. The chute should be extended to below the normal downstream channel elevation. At least one row of baffles should be buried in the backfill.
- 9) **Wall Height:** The chute training walls should be three times as high as the baffle piers (measured normal to the chute floor) to contain the main flow of water and splash. It is impractical to increase the wall heights to contain all the splash.

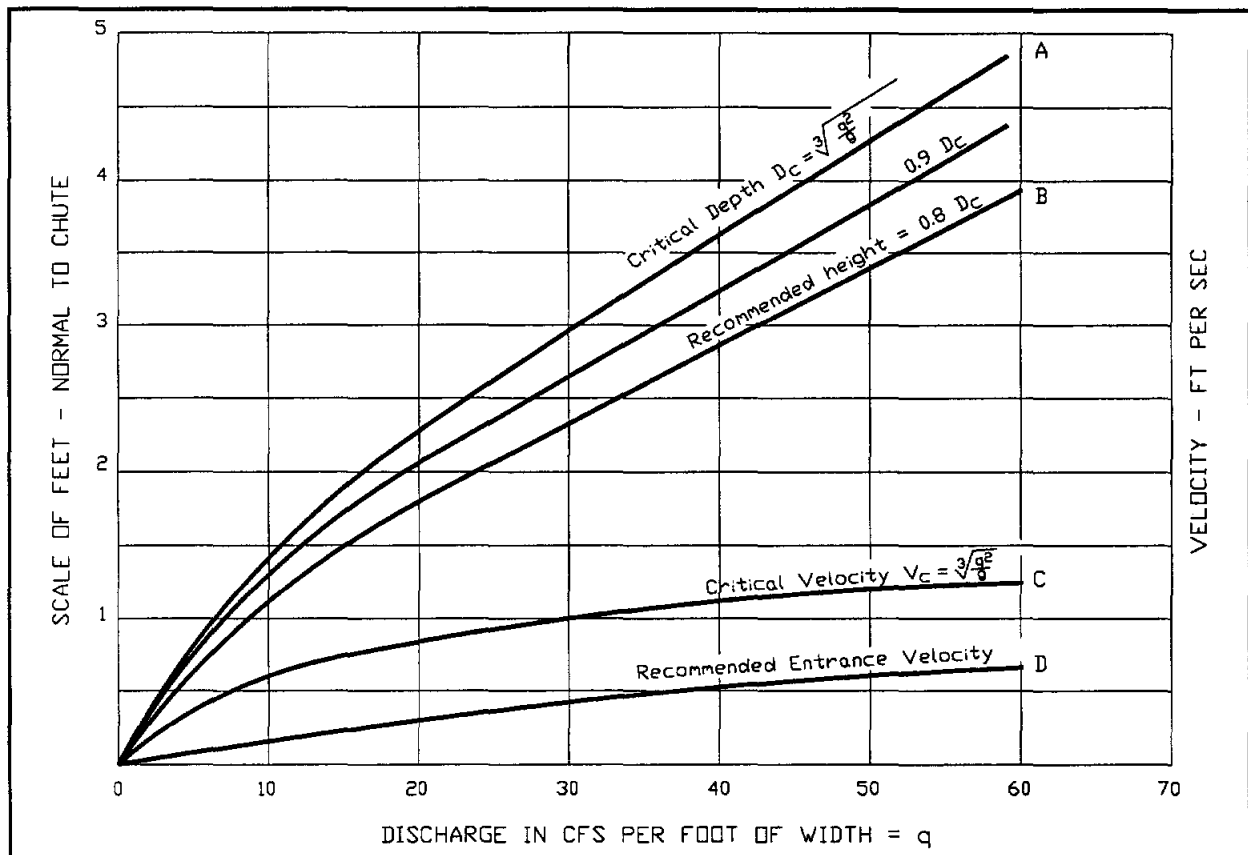

FIGURE 6.9 Recommended Baffle Pier Heights and Allowable Velocities (Source: (USBUREC, 1961))

- 10) **Downstream Rip-rap:** Rip-rap consisting of 6-inch to 12-inch stones should be placed at the downstream ends of the training walls to prevent eddies from undermining the walls.

6.2.5.6 SAF-Type Stilling Basins

The SAF stilling basin was developed by the Saint Anthony Falls Hydraulic Laboratory at the University of Minnesota. SAF-type basins are intended for use on small drainage structures such as those built by the U.S. Soil Conservation Service. Typical SAF stilling basin configurations, dimensions, and design terms are illustrated on Figures 6.10 through 6.15. The following design procedure is taken from *Open Channel Hydraulics* [Chow, 1959]:

- 1) **Basin Length:** The length L_B of the stilling basin for Froude numbers between $F_1 = 1.7$ and $F_1 = 17$ is determined by $L_B = 4.5y^2/F_1^{0.76}$.
- 2) **Block Height:** The height of the chute blocks and floor blocks is y_1 , and the width and spacing are approximately $0.75y_1$.
- 3) **Block Location:** The distance from the upstream end of the stilling basin to the floor blocks is $L_B/3$. No floor block should be placed closer to the side wall than $3y_1/8$. The floor blocks should be placed downstream from the openings between the chute blocks.
- 4) **Block Width:** The floor blocks should occupy between 40 and 55% of the stilling basin width. The widths and spacings of the floor blocks for trapezoidal stilling basins should be increased in proportion to the increase in stilling basin width at the floor block location.

- 5) **End Sill:** The height of end sill is given by $c = 0.07y_2$, where y_2 is the theoretical sequent depth corresponding to y_1 .
- 6) **Tailwater Depth:** The depth of tailwater above the stilling basin floor is given by:
- $$y_2' = (1.10 - F_1^2/120)y_2 \quad \text{for } F_1 = 1.7 \text{ to } 5.5$$
- $$y_2' = 0.85y_2 \quad \text{for } F_1 = 5.5 \text{ to } 11$$
- $$y_2' = (1.00 - F_1^2/800)y_2 \quad \text{for } F_1 = 11 \text{ to } 17.$$
- 7) **Side Wall Height:** The height of the side wall above the maximum tailwater depth to be expected during the life of the structure is given by $z = y_2'/3$.
- 8) **Wing Wall Height:** Wing walls should be equal in height to the stilling basin side walls. The top of the wing wall should have a slope of 1 on 1.
- 9) **Wing Wall Alignment:** The wing wall should be placed at an angle of 45 degrees to the outlet center line.
- 10) **Side Wall Alignment:** The stilling basin side walls may be parallel (as in a rectangular stilling basin) or they may diverge as an extension of the transition side walls (as in a trapezoidal stilling basin).
- 11) **Cutoff Wall:** A cutoff wall of nominal depth should be used at the end of the stilling basin.
- 12) **Entrained Air:** The effect of entrained air should be neglected in the design of the stilling basin.

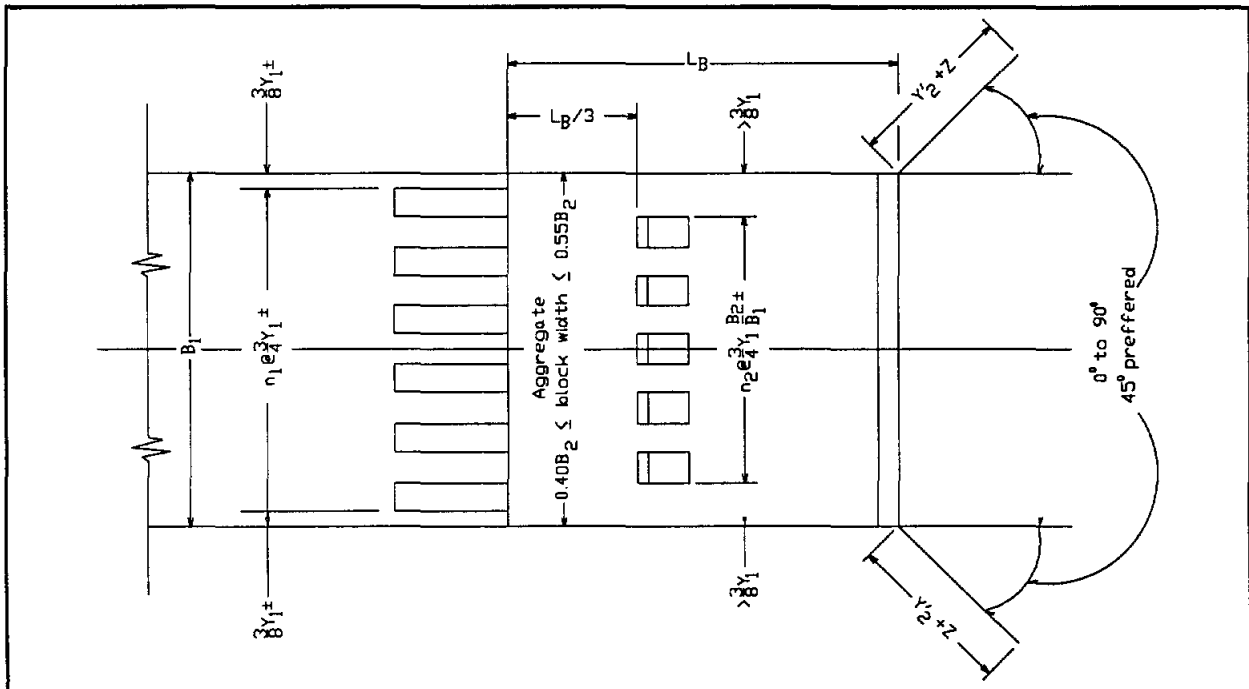

FIGURE 6.10 Plan View of Rectangular SAF-Type Stilling Basin

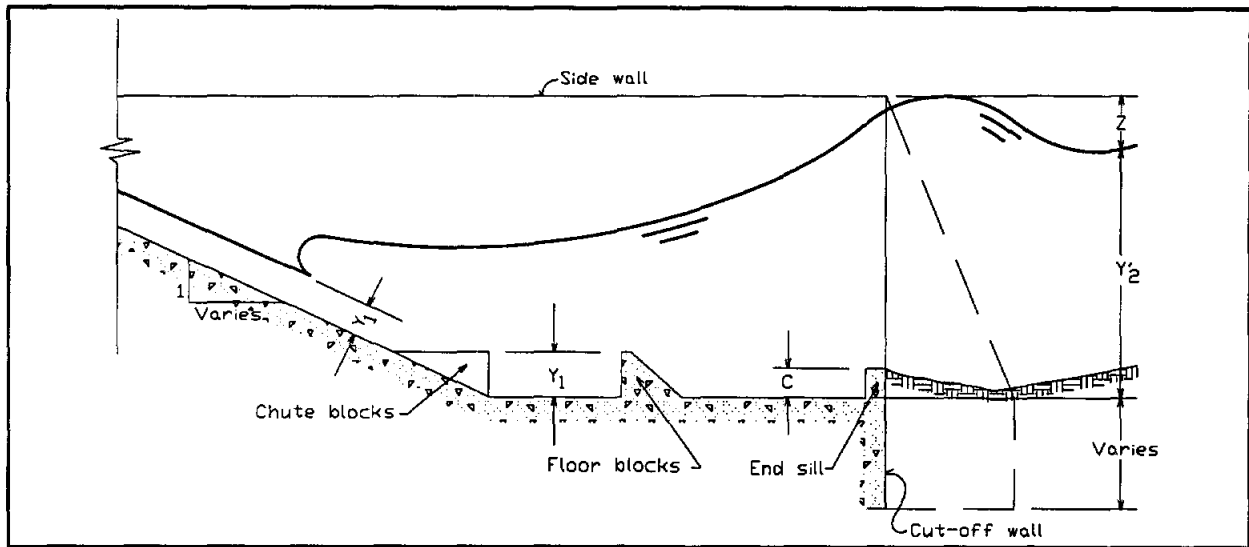

FIGURE 6.11 Center-Line Section of Rectangular SAF-Type Stilling Basin

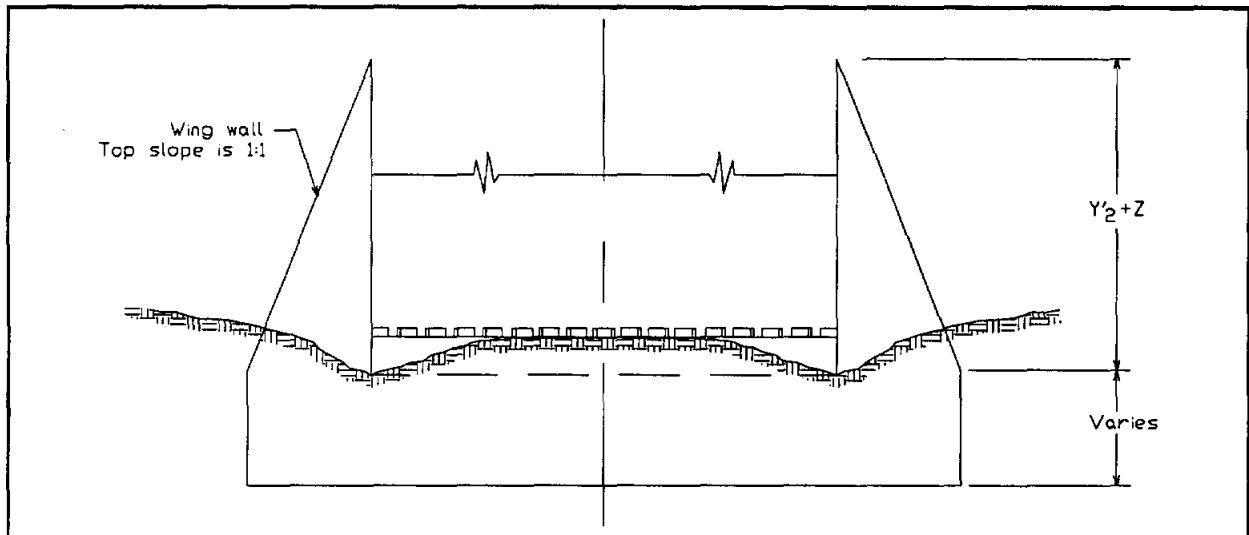

FIGURE 6.12 Downstream Elevation of Rectangular SAF-Type Stilling Basin

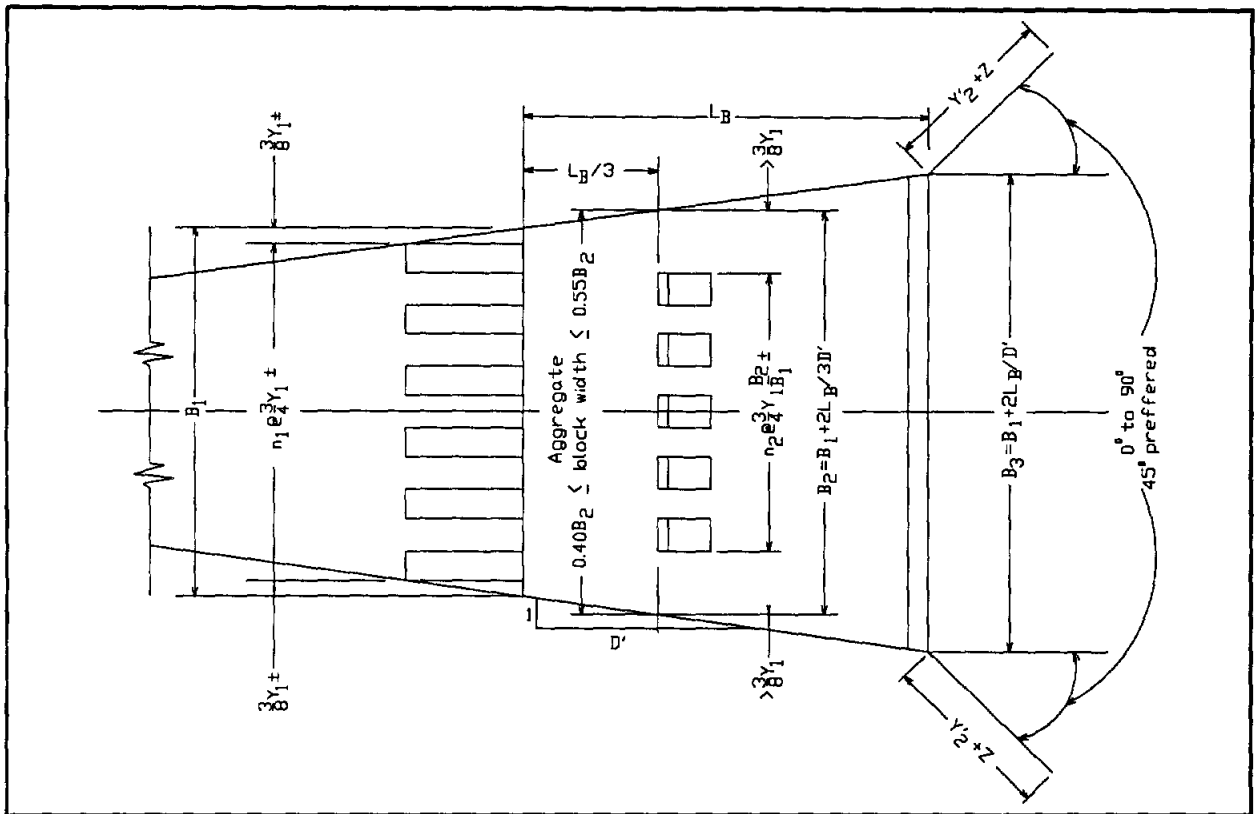

FIGURE 6.13 Plan View of Trapezoidal SAF-Type Stilling Basin

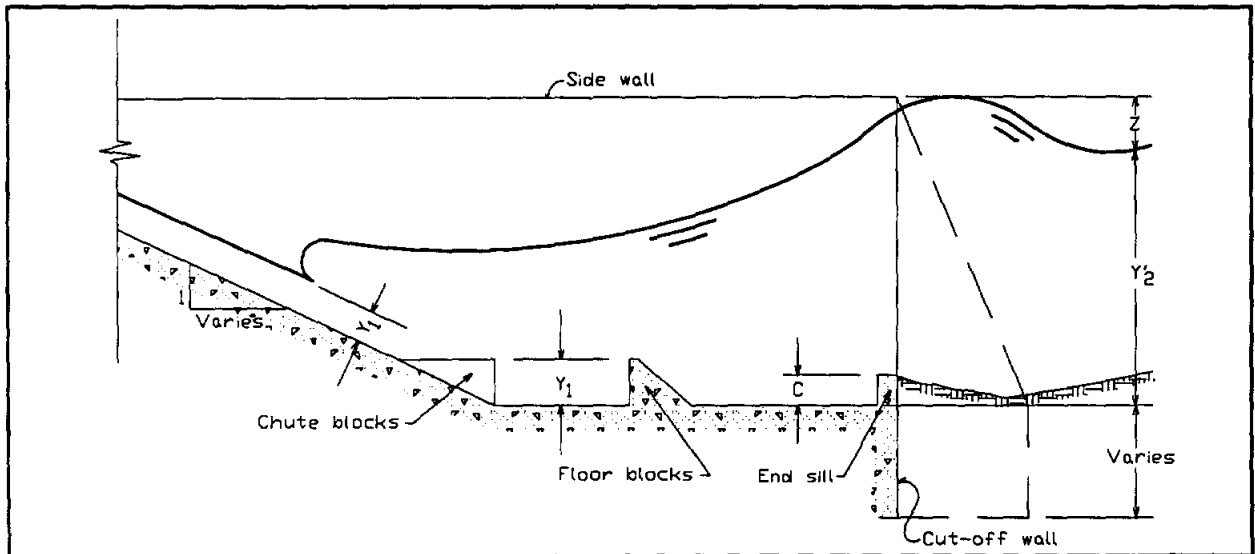

FIGURE 6.14 Center-Line Section of Trapezoidal SAF-Type Stilling Basin

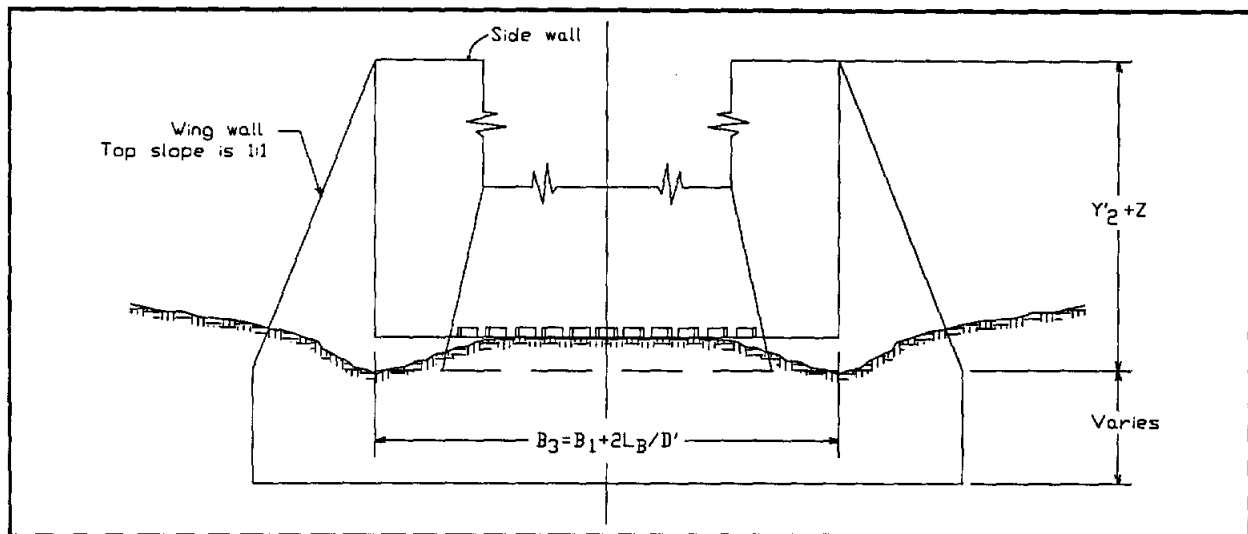

FIGURE 6.15 Downstream Elevation of Trapezoidal SAF-Type Stilling Basin

6.3 SECONDARY DRAINAGE SYSTEMS

6.3.1 Backslope Drainage Systems

The use of backslope drains and swales is required in Montgomery County. These systems collect overland flow from channel overbanks and other areas not draining to the storm sewer collection system. Their purpose is to prevent excessive overland flow from passing over the banks of grass-lined channels and eroding the side slopes. Subject to County approval, backslope drains may not be required in undeveloped or sparsely developed areas.

The design engineer should carefully consider the drainage area to be intercepted by such systems, particularly when the channel passes through large areas of undeveloped acreage where large quantities of naturally occurring sheet flow could overload the backslope swale and drainage system. In these areas, the minimum requirements for drain spacing and backslope drainage pipe discussed below may not be adequate. Refer to Figure 6.16 for backslope drain design.

Documentation of drainage area for each backslope drain system as well as hydraulic pipe and swale sizing calculations must be provided by the engineer.

General requirements for backslope drains and swales have been taken from the *Criteria Manual for Design of Flood Control and Drainage Facilities in Harris County, Texas* [HCFCD, 1984], and are as follows:

- 1) **Minimum Pipe Size:** Minimum backslope drain pipe shall be 24" in diameter.
- 2) **Maximum Spacing:** Maximum spacing is 800 feet (or 400 feet to the swale high point).
- 3) **Location:** The drain structure and swale center-line should be five feet inside the channel right-of-way line.
- 4) **Design Depth:** Minimum design depth in swale is 0.5 feet. Maximum design depth in swale is 2.0 feet.
- 5) **Grade:** Minimum gradient for swale invert is 0.2%.
- 6) **Side Slope:** Swale should have a maximum (steepest) side slope of 1.5:1.

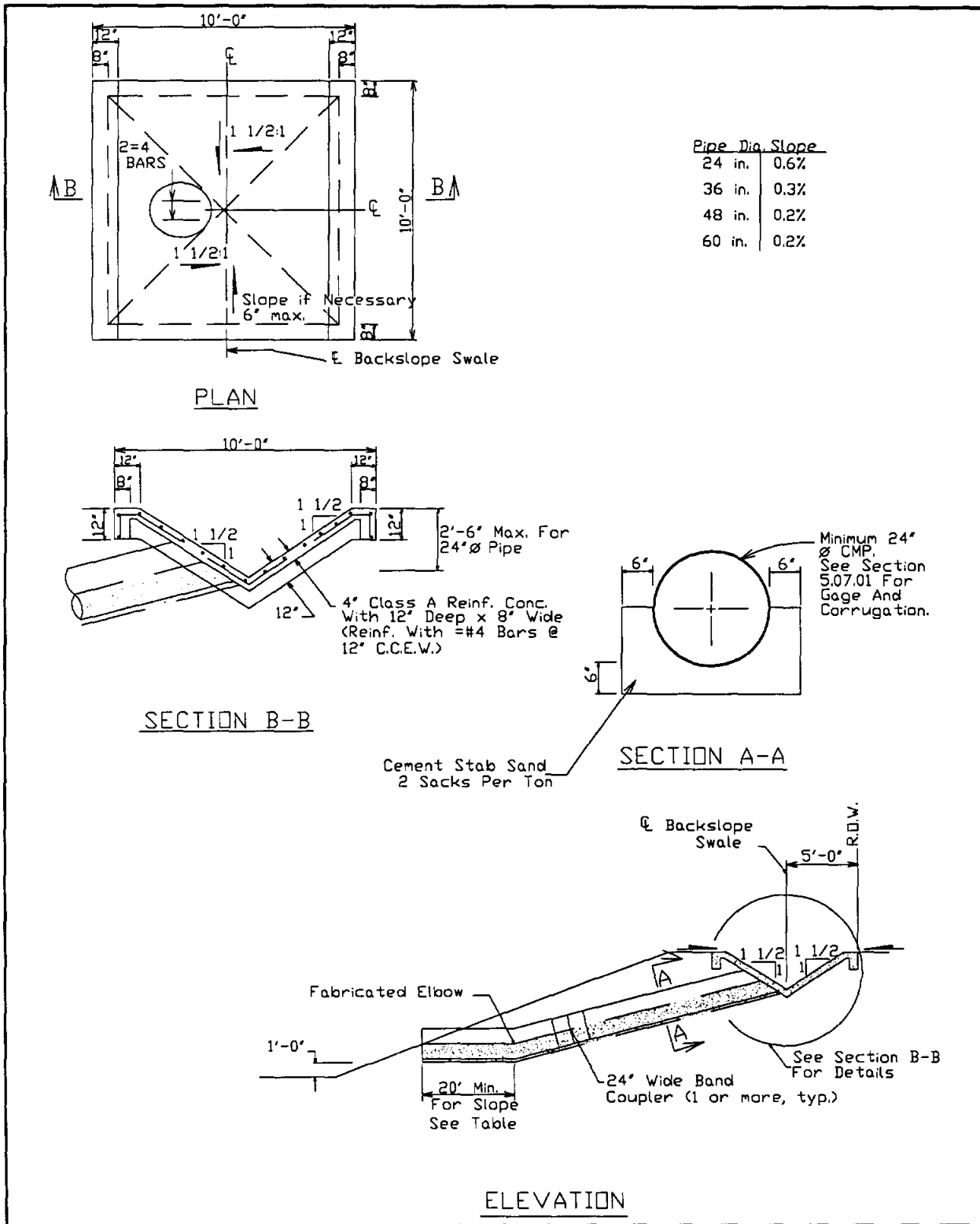

FIGURE 6.16 Typical Backslope Interceptor Structure

6.3.2 Pipe Outfalls

A major source of erosion in channels is around pipe outfalls, either from storm sewers or from backslope interceptor structures. Erosion can occur in the channel bottom and on the opposite bank due to high flows from such pipes. In addition, improperly installed pipes result in seepage, piping, and erosion around the outside wall of the pipe. The best way to prevent seepage is to construct tight pipe joints, to backfill with cement stabilized sand, and to compact the backfill properly. Figures 5.5 and 5.6 contain minimum requirements for pipe outfall construction.

Erosion downstream of the pipe can be prevented by installing rip-rap or concrete slope paving. The use of rip-rap is recommended because it is flexible and it reduces the water velocity coming out of the pipe. Problems have occurred in the past with concrete slope paving breaking off the outfall pipe due to undermining of the slope paving.

Erosion protection is required for all pipes 48 inches in diameter and larger. For pipes less than 48 inches, erosion protection is optional, except in channels where severe erosion problems exist or are anticipated.

Figure 5.6 illustrates the requirements for erosion protection placement at the end of the pipe. The distance the rip-rap or slope paving needs to extend across the ditch is given as six times the diameter of the pipe or up to the elevation of the top of pipe on the opposite bank, whichever results in a shorter distance. The purpose of this dual guideline is to attempt to cover most combinations of pipe and channel sizes. For example, a 6-foot diameter pipe outfalling into a 6-foot wide bottom channel definitely needs opposite bank protection, but the same pipe in a 40-foot wide bottom channel would not need opposite bank protection.

The purpose of installing outfall pipes one foot above the channel flow-line or normal water level is to insure continued operation of the pipe if the channel silts up. A distance larger than one foot would create erosion problems in the channel under the end of the pipe.

6.3.3 Roadside Ditch Interceptor Structures

A roadside ditch interceptor structure and adequately sized pipe should be used to convey flow from relatively small ditches into major drainage channels (Figure 6.17). Flow over the banks of grass-lined channels is not acceptable due to potential erosion problems. The interceptor pipe should be sized based on the drainage area served by the small ditch and design frequency for the ditch.

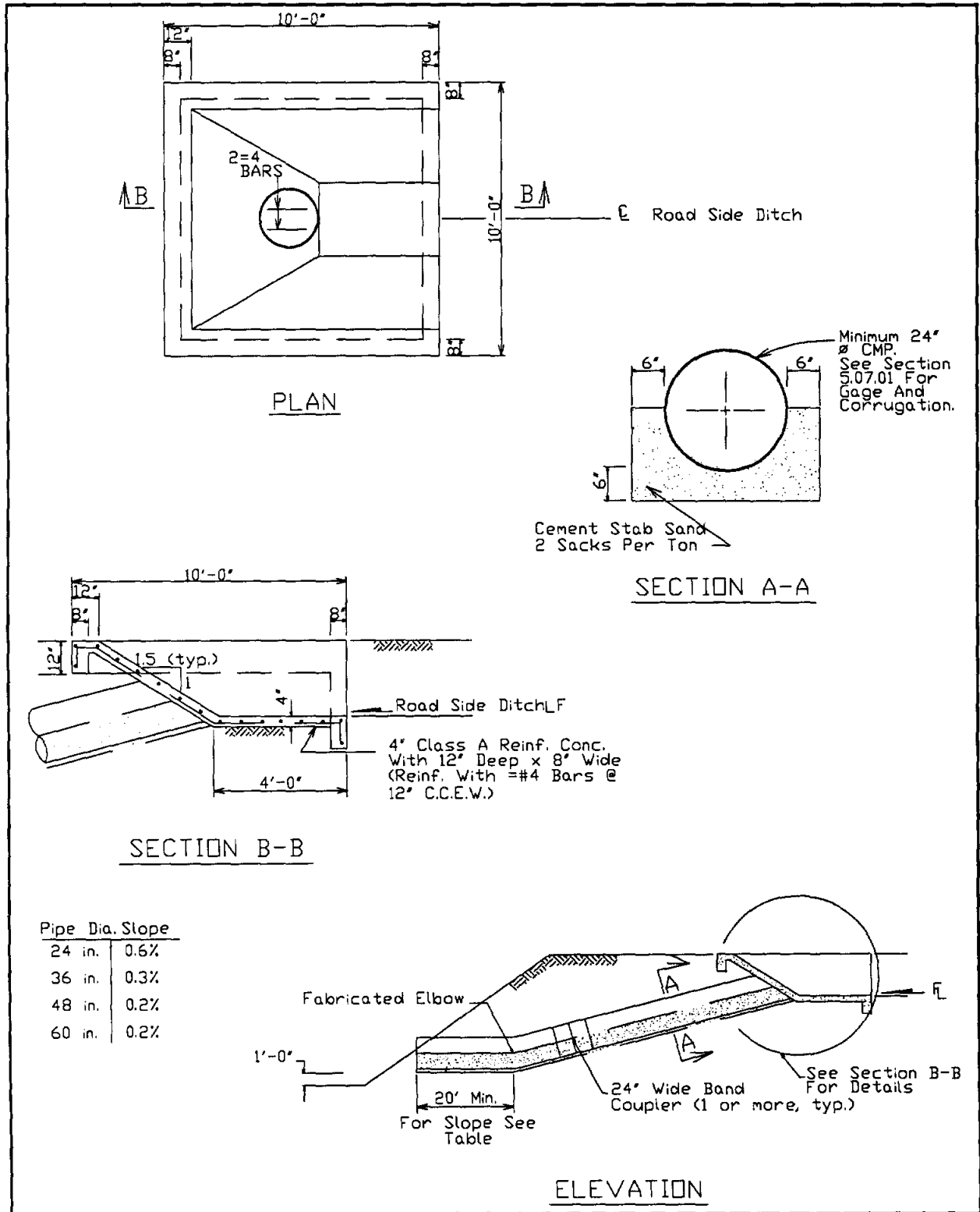

FIGURE 6.17 Typical Roadside Ditch Interceptor Structure

6.4 SEDIMENT CONTROL DURING CONSTRUCTION

Erosion control measures should be applied during construction of any development to prevent siltation of any affected channels and/or storm sewer systems. Channel siltation caused by construction activities is a major problem in Montgomery County, resulting in reduced channel capacity and an additional financial burden on Montgomery County maintenance funds.

Upon completion of a new channel or channel improvements in a subdivision, the County Drainage Administrator will inspect and accept only the channel portion of the project. Inspectors will not accept the storm sewer outfalls until a request is made for acceptance of the subdivision streets and storm sewers. At that time, the storm sewer outfall must be free of silt and backwater. Any sedimentation which occurs during construction of a subdivision or development must be removed and the channel restored to its design condition.

SECTION 7 DETENTION DESIGN

The introduction of impervious cover and improved runoff conveyance serves in many cases to increase flood peaks quite dramatically over those for existing conditions. When physical, topographic, and economic conditions allow it, channel improvements downstream of the development are often used to prevent increased flooding. When this is not feasible, a widely used practice is runoff detention or retention storage, wherein the storm volume is held back in the watershed and released at an acceptable rate. This section of the manual presents information on storage techniques, including guidance for the design of appropriate storm runoff storage facilities.

Development in a watershed can have complex and far-reaching consequences on the overall hydrologic regime. For this reason, careful plans for anticipating and meeting the long term flood control and drainage needs of Montgomery County have been drawn up on a watershed-by-watershed basis. Each watershed "master plan" has been formulated to provide the most practical and efficient basin-wide approach to the hydrologic consequences of ongoing or future development, including proper coordination of storm detention facilities and channel improvements. Accordingly, the Montgomery County Drainage Administrator must be consulted concerning preferred watershed flood control strategies and alternatives.

7.1 TYPES OF STORAGE FACILITIES

Storage systems may be classified as either on-line or off-line facilities. They may be designed for either detention or retention of stormwater. Figures 7.1 and 7.2 illustrate a typical detention facility.

7.1.1 Off-Line Facilities

An *off-line detention facility* is one in which storm runoff does not begin to flow into the storage facility until the discharge in the channel reaches some critical value above which unacceptable downstream flooding will occur. An off-line facility serves to store only the runoff volume associated with the high flow rate portions of the flood event.

7.1.2 On-Line Facilities

An *on-line detention facility* is one in which the total storm runoff volume passes through the retention or detention facility's outflow structure.

An *in-stream detention facility* is a special type of on-line facility created by restricting the discharge of a segment of a drainage channel. In-stream detention facilities are acceptable if the drainage channel receives runoff only from the property for which the detention capacity is being provided. However, in-stream detention facilities which receive runoff from other upstream properties will not be approved.

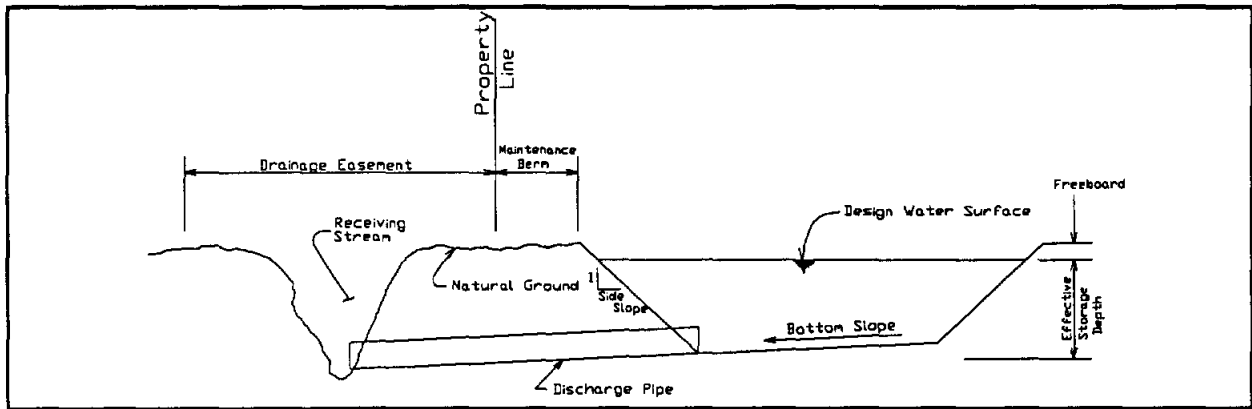

FIGURE 7.1 Cross-Section of Typical Detention Basin

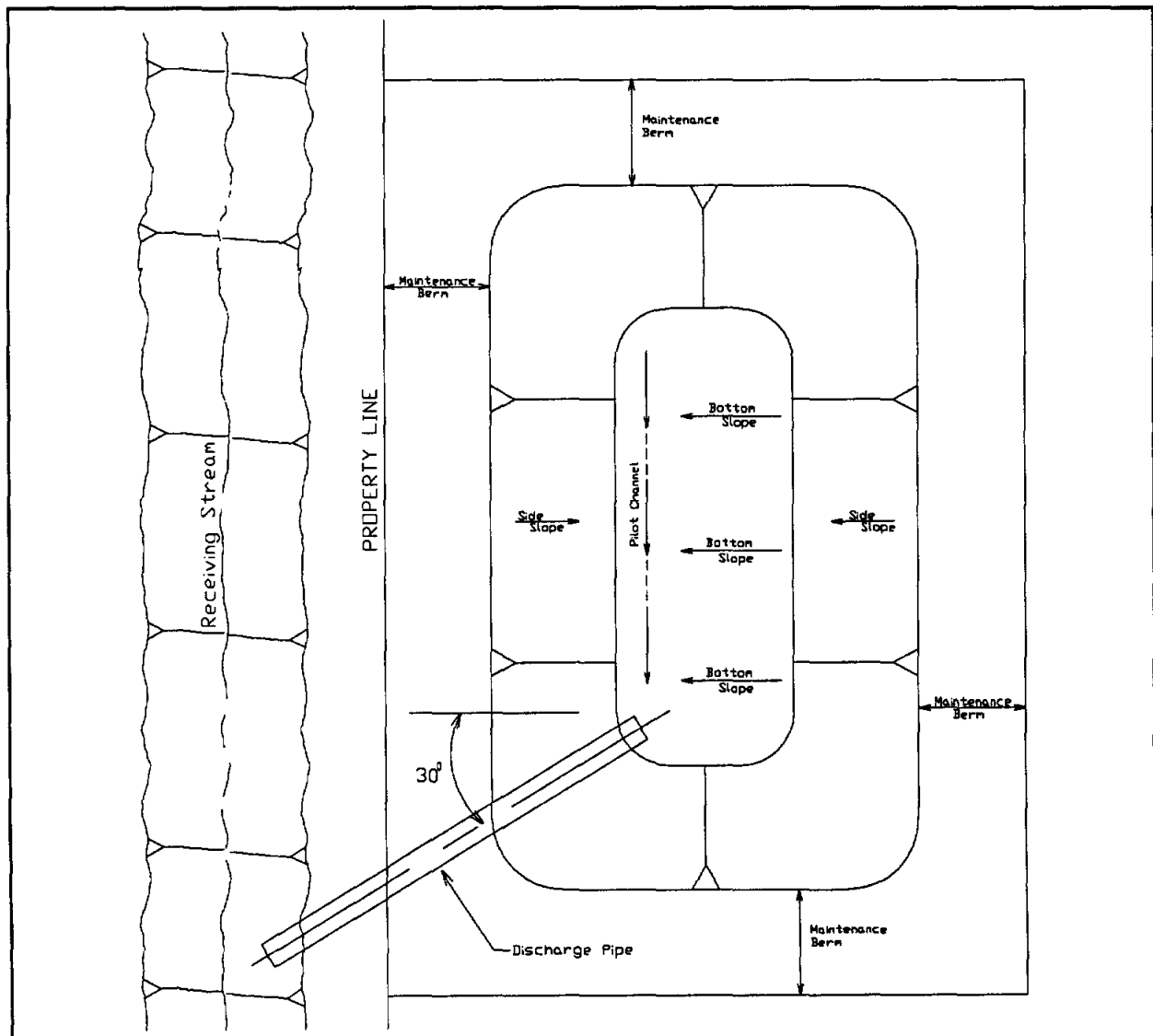

FIGURE 7.2 Typical Detention Basin Configuration

7.1.3 Retention Storage

In a **retention** storage facility, runoff is captured and released only after the storm event is over and the downstream water surface has subsided. A retention storage system is seldom used. Special outlet devices or pumps are usually required for such systems. Figure 7.3 illustrates the effect of retention storage on developed conditions runoff hydrographs.

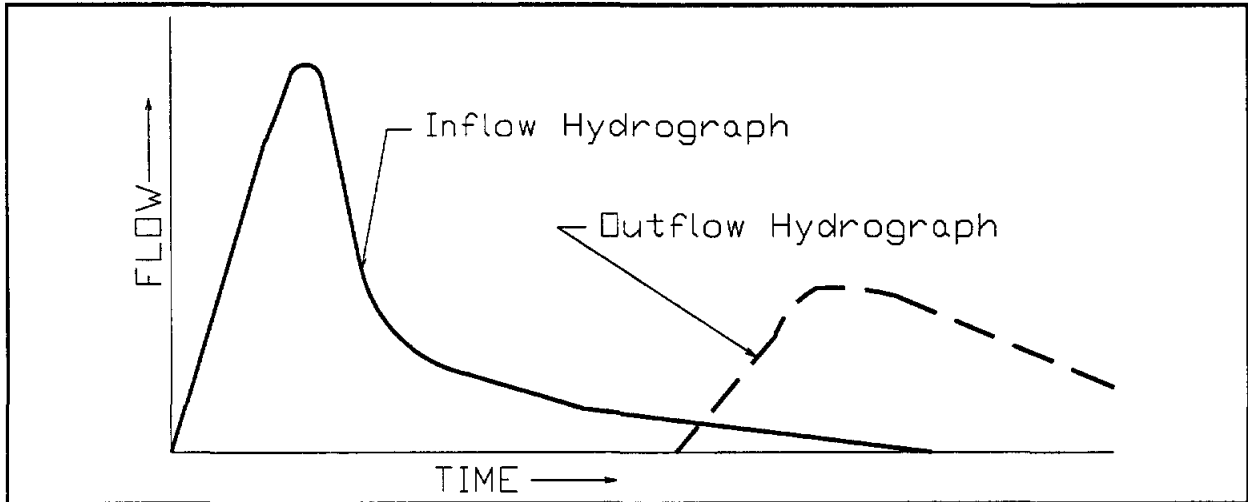

FIGURE 7.3 Effect of Retention Storage on Hydrographs

7.1.4 Detention Storage

The vast majority of flood control storage is handled by **detention** facilities. The purpose of detention storage is to hold storm runoff back but release it continuously at an acceptable rate through a flow-limiting outlet structure, thus controlling downstream peak flows. Figure 7.4 illustrates the typical effect of detention storage facilities on developed conditions runoff hydrographs.

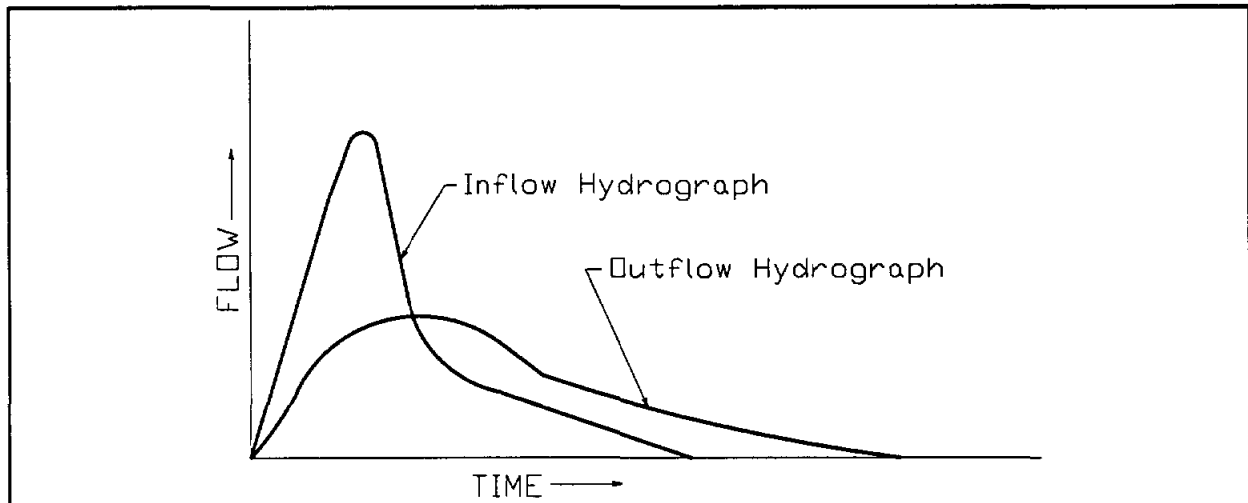

FIGURE 7.4 Effect of Detention Storage on Hydrographs

7.2 DESIGN CONSIDERATIONS

7.2.1 Location of Facility

Detention basins should be located on or near primary drainage channels. This allows for a direct connection between the basin and the stream which receives discharges from it. In addition, detention basin locations should be chosen to facilitate the drainage of storm runoff into the basin. Care should be exercised to insure that detention facilities are constructed in locations which allow easy access for maintenance purposes.

7.2.2 Storm Sewer Hydraulic Gradients

The hydraulic gradients in storm sewers shall be determined using procedures outlined in SECTION 5. The starting water surface elevation for these calculations shall be the 25-year maximum pond elevation.

7.2.3 Allowances for Extreme Storm Events

Design consideration must be given to storm events in excess of the 100-year flood. An emergency spillway, overflow structure, or swale must be provided as necessary to effectively handle the extreme storm event. In places where a dam has been utilized to provide detention directly in the channel, due consideration must be given the consequences of a failure, and if a significant hazard exists, the dam must be adequately designed to prevent such hazards.

In addition, detention facilities which measure greater than six feet in height are subject to regulation by the Texas Water Commission [TWC, 1986]. The height of a detention facility or dam is the distance from the lowest point on the crest of the dam (or embankment), excluding spillways, to the lowest elevation on the center-line or downstream toe of the dam (or embankment), including the natural stream channel. Water Commission regulations classify dam sizes and hazard potential and specify required failure analyses and spillway design flood criteria [TWC, 1986].

7.2.4 Multi-Purpose Use of Detention Facilities

The amount of land required for a stormwater detention facility is generally quite substantial. For this reason, storage facilities may serve a secondary role as parks or recreational areas whenever possible. Conversely, parking areas may serve a secondary role as storage facilities as long as the 100-year ponding depth within the parking area is six inches or less where cars are parked. Such dual use areas will be allowed only after proper review of the design scenario and approval of the specific project by the Montgomery County Drainage Administrator.

When a dual use facility is proposed, a joint use agreement is required between Montgomery County and the entity sponsoring the secondary use. This agreement must specify the maintenance responsibilities of each party.

For privately maintained or dual use systems, each stormwater detention facility will be reviewed and approved only if: 1) The facility has been designed to meet or exceed the requirements contained within this manual; and 2) Provisions are made for the facility to be adequately maintained.

7.2.5 Aesthetic Aspects of Detention Facility Design

Due consideration should be given to aesthetic aspects of detention facility design. The use of reduced (flatter) side slopes, landscaping, and other measures to improve the appearance of detention basins should be considered.

7.2.6 Safety Considerations in Detention Facility Design

Safety should also be given careful consideration in detention basin designs. Embankment slopes, railings, fences, grates, and other features should be incorporated into the design of the facility wherever appropriate. Appropriate warning signs should be placed around the perimeter of the facility.

Designs of detention outlet structures should, wherever possible, incorporate grates and other appropriate safety features. Flow velocities should be limited to avoid the formation of dangerous undertows.

Wherever possible, the depth of water near the edge of the basin should be limited to reduce hazards to persons venturing near the water's edge. Limiting the embankment slope to a value which would allow a person to easily escape from the basin should also be considered.

7.2.7 Erosion Control Measures for Detention Facilities

The erosion potential for a detention basin is similar to that of an open channel. For this reason the same types of erosion protection are necessary, including the use of backslope swales and drainage systems (as outlined in SECTION 6), proper revegetation, and pond surface lining where necessary. Proper protection must especially be provided at pipe outfalls into the facility, pond outlet structures and overflow spillways where excessive turbulence and velocities will cause erosion.

7.2.8 Maintenance of Detention Facilities

In general, Montgomery County will only be responsible for maintenance of stormwater detention basins which serve public facilities such as dedicated public streets or parks and recreational areas. Responsibility for the maintenance of any portion of a facility not designed for flood control will not rest with Montgomery County, nor will the County be responsible for any damage which may occur resulting from flooding of the facility.

A 30-foot wide access and maintenance easement shall be provided around the entire detention pond. This is in addition to the dedication required for the pond itself.

7.3 DETENTION DESIGN PROCEDURES

7.3.1 Detention Design Frequencies

All detention facilities in South Montgomery County shall be designed to attenuate developed conditions peak flow rates from the 25-year and 100-year frequency, 24-hour duration storm to existing conditions levels. No increase in downstream flow rates or flood levels will be allowed.

The maximum 100-year water surface elevation in all detention facilities shall be a minimum of 1 foot below the minimum top of bank elevation of the basin. In addition, all detention facilities must be designed to have sufficient freeboard to provide for adequate drainage of lateral storm sewers during the 25-year storm.

7.3.2 Required Documentation for Detention Facility Designs

The following information must be submitted to the Montgomery County Drainage Administrator for the design of detention facilities:

- 1) **Vicinity Map:** A vicinity map which illustrates the location of the proposed development and detention site.
- 2) **Site Map:** A detailed map of the proposed development and detention site with all pertinent physiographic information.

- 3) **Watershed Map:** A watershed map showing existing and proposed drainage area boundaries along with all sub-area delineations and all areas of existing or proposed development.
- 4) **Discharge Calculations:** Discharge calculations specifying the methodology and key assumptions used, along with computed peak flow rates or hydrographs.
- 5) **Hydraulic Calculations:** Hydraulic calculations for outlet structure design, specifying the methodology used. All assumptions and values of design parameters must be clearly stated.
- 6) **Right-of-Way Map:** A map illustrating all existing and proposed rights-of-way.
- 7) **Benchmark Information:** A description of the benchmark used in obtaining field survey data, including the location, elevation, datum, and year of adjustment.
- 8) **Facility Layouts:** Plan view and typical cross-section(s) of proposed detention facility.
- 9) **Soils Report:** A soils report which addresses erosion and slope stability.

7.3.3 Detention Design For Drainage Areas of Less Than 50 Acres

The maximum allowable release rate from the detention facility during the 100-year storm event is the 100-year peak flow rate from the watershed of the detention facility under pre-development conditions. This flow rate should be determined using the Rational Method.

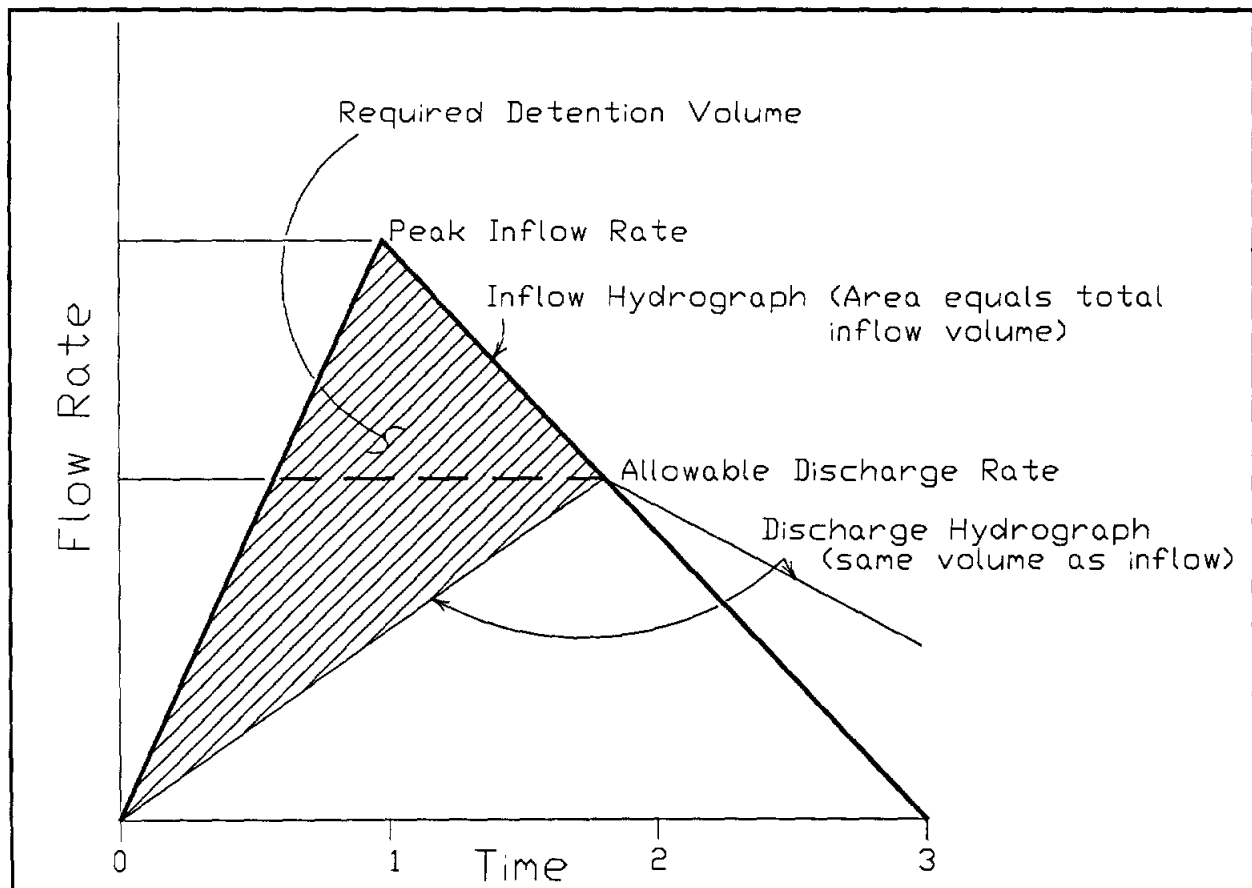

FIGURE 7.5 Required Detention Volume for Less Than 50 Acres

The volume of flood control storage to be provided by the facility for the 100-year storm event is to be determined using the triangular hydrograph method illustrated in Figure 7.5. The required volume may be computed using the following formulas:

$$B = \frac{43560V_R}{0.5I} \quad \text{Equation 7.1}$$

$$S = \frac{0.5B(I - O)}{43560} \quad \text{Equation 7.2}$$

in which:

B = duration of inflow to the basin (seconds)

V_R = total basin inflow volume (acre-feet)

S = required flood storage volume (acre-feet)

I = peak inflow rate (cubic feet per second)

O = peak discharge rate (cubic feet per second).

This storage volume must be provided below the proposed maximum 100-year water surface elevation in the basin. The required storage volume for the 25-year storm event should be computed in the same way. The 25-year ponding elevation should be determined as the elevation below which the computed storage volume may be provided within the detention basin.

The size of the outlet pipe that is require to pass the maximum allowable release rate during the 100-year storm is to be computed assuming outlet control (See SECTION 4), by establishing a maximum ponding level in the detention facility during the 100-year storm and determining the appropriate a tailwater elevation in the outfall channel.

7.3.4 Detention Design For Drainage Areas of 50 Acres to 640 Acres

For drainage areas greater than or equal to 50 acres but less than 640 acres (one square mile), an inflow hydrograph must be developed and routed through the detention facility. The inflow hydrograph may be assembled using the drainage area versus peak discharge curves for Montgomery County and the Small Watershed Method of hydrograph development, both of which are described in SECTION 2. Alternatively, the inflow hydrograph may be developed using the HEC-1 computer program and the guidelines for HEC-1 applications presented in SECTION 2.

Routing of flows through the detention facility may be accomplished using the **Modified Puls** method. This method is described by the equation:

$$\frac{I_1 + I_2}{2} \Delta t + S_1 - \frac{O_1}{2} \Delta t = S_2 + \frac{O_2}{2} \Delta t \quad \text{Equation 7.3}$$

in which:

I = instantaneous inflow rate at the beginning of a routing period (cfs)

O = instantaneous outflow rate at the beginning of a routing period (cfs)

S = instantaneous storage volume at the beginning of a routing period (cfs)

Δt = duration of routing period (seconds).

The HEC-1 computer program may be used to perform detention routing computations using the Modified Puls method. Other programs which utilize the Modified Puls method are available. The routing equation given above may also be solved graphically and used in manual routing computations.

The existence of flooding problems in downstream areas may make the use of the HEC-1 program essential for the design and analysis of some detention basins which fall within this category. The Montgomery County Drainage Administrator should be consulted to determine whether a detailed analysis of downstream impacts using the HEC-1 program is required for a particular watershed or detention basin location.

7.3.5 Detention Design For Drainage Areas of 640 Acres or More

For drainage areas greater than or equal to 640 acres (one square mile), the HEC-1 computer program will be used to analyze the operation of the proposed detention facility and to insure that downstream flooding conditions will not be increased. An existing conditions HEC-1 model of the entire watershed should first be established in conjunction with the Montgomery County Drainage Administrator. Once existing conditions are established, the proposed development and detention facility will be analyzed for the 10-, 25- and 100-year storm events (and smaller events if the downstream channel has less than 10 year capacity). The detention facility will be sized to allow an appropriate release rate that will not cause any increase in flood levels in downstream areas.

7.3.6 Design Tailwater Depth for Detention Facilities

There are two tailwater conditions which may be applied to detention basin design; a constant tailwater elevation or tailwater elevations which vary with time. In reality, the water level in the outfall channel will always vary with time during a runoff event due to flow from the watershed upstream of the detention pond outfall as well as the outflow from the pond. Routing a hydrograph through a detention pond should incorporate the effect of the variable tailwater on the outflow. However, in most cases the development of a storm hydrograph in the outfall channel requires extensive watershed modeling.

For detention facilities which outfall at a location on a channel where the upstream drainage area is greater than 2,000 acres, the use of variable tailwater elevations is recommended. Check with the Montgomery County Drainage Administrator to find out what hydrologic information is available for the subject watershed and, if necessary, to discuss procedures for developing hydrographs.

For detention facilities which outfall at a location on a channel where the upstream drainage area is less than 2,000 acres, the use of a constant tailwater elevation is allowed. For the 100-year storm, the tailwater elevation used should be two feet below the maximum 100-year water surface elevation in the detention pond or the maximum 100-year water surface elevation in the outfall channel, whichever is lower. For the 25-year storm, the tailwater elevation should be equal to the maximum 25-year water surface elevation in the outfall channel. In no instance, however, should the design tailwater elevation should be less than that of the top (crown) of the outlet pipe.

7.3.7 Detention Outlet Structure Design

The primary detention outlet structure shall be designed to convey the maximum 100-year detention discharge. The following types of detention outlet structures may be utilized:

- 1) Outflow Pipes or Culverts
- 2) Horizontal Weirs
- 3) V-Notch Weirs
- 4) Orifices
- 5) Outlet Pipes with Risers

The use of other types of outlet structures should be approved by the Montgomery County Drainage Administrator prior to the completion of any detailed design computations.

7.3.8 Outflow Pipes or Culvert

Figure 7.6 illustrates a typical detention outlet pipe. The minimum cross-sectional dimension is 24 inches. The minimum culvert slope is that required for a flow velocity of 3 fps at full gravity flow conditions. Detention outflow pipes are generally examples of culverts operating under outlet control conditions, and may thus be analyzed using the methods described in SECTION 4.1.9.2.

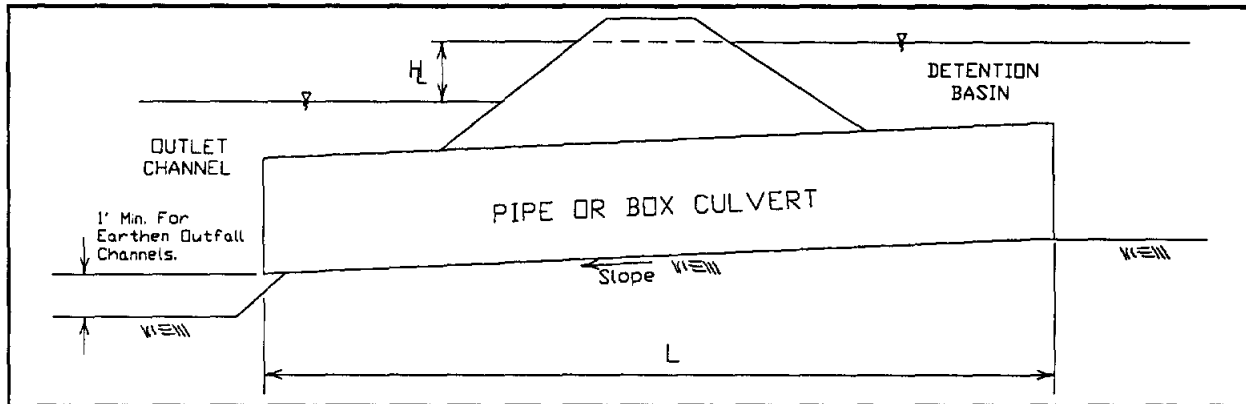

FIGURE 7.6 Typical Pipe or Box Culvert Outlet Structure

7.3.9 Horizontal Weir

Figure 7.7 shows a typical sharp-crested horizontal weir. Horizontal weirs are useful when a large rate of discharge must be developed with a relatively small head loss.

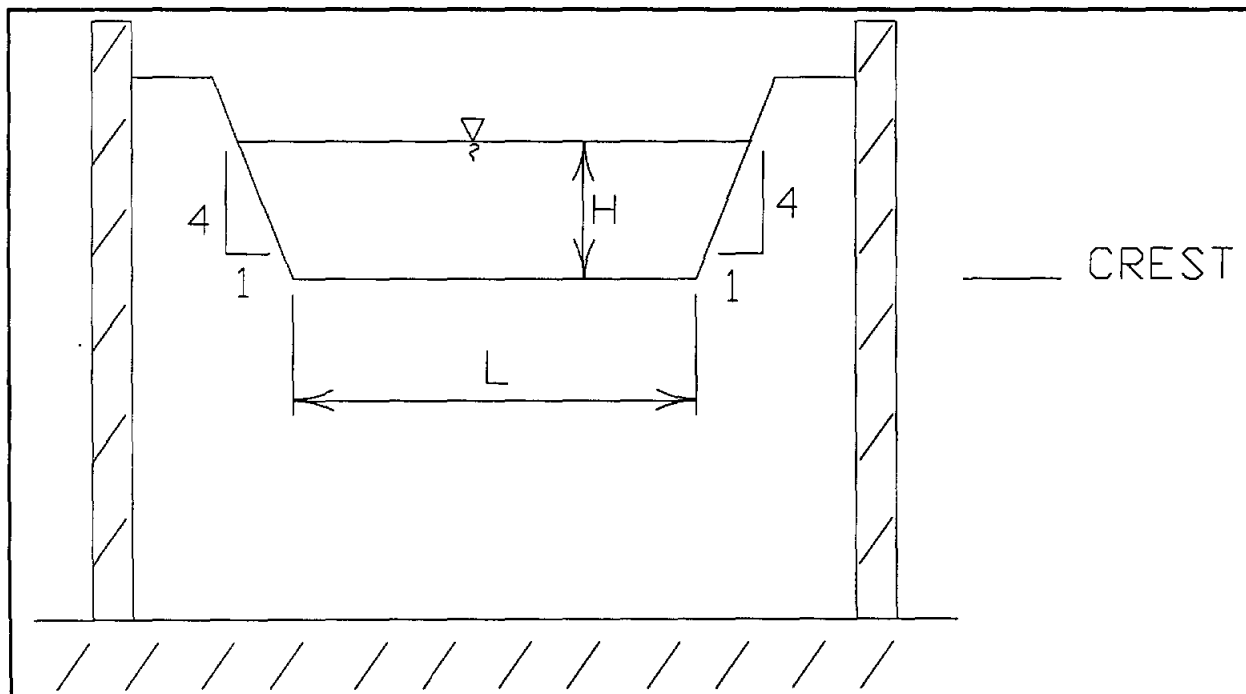

FIGURE 7.7 Sharp-Crested Rectangular Weir

The 4:1 side slope on the sides of the weir offset the effects of end contractions and allow the full width of the weir (L) to be used in the weir flow equation:

$$Q = CLH^{1.5}$$

Equation 7.4

in which:

Q = the flow capacity of the weir (cfs).

C = the weir flow coefficient. Values are available in most hydraulics textbooks.

H = the head on the weir (ft), measured above the crest of the weir.

Figure 7.8 shows a sharp-crested weir in cross-section view.

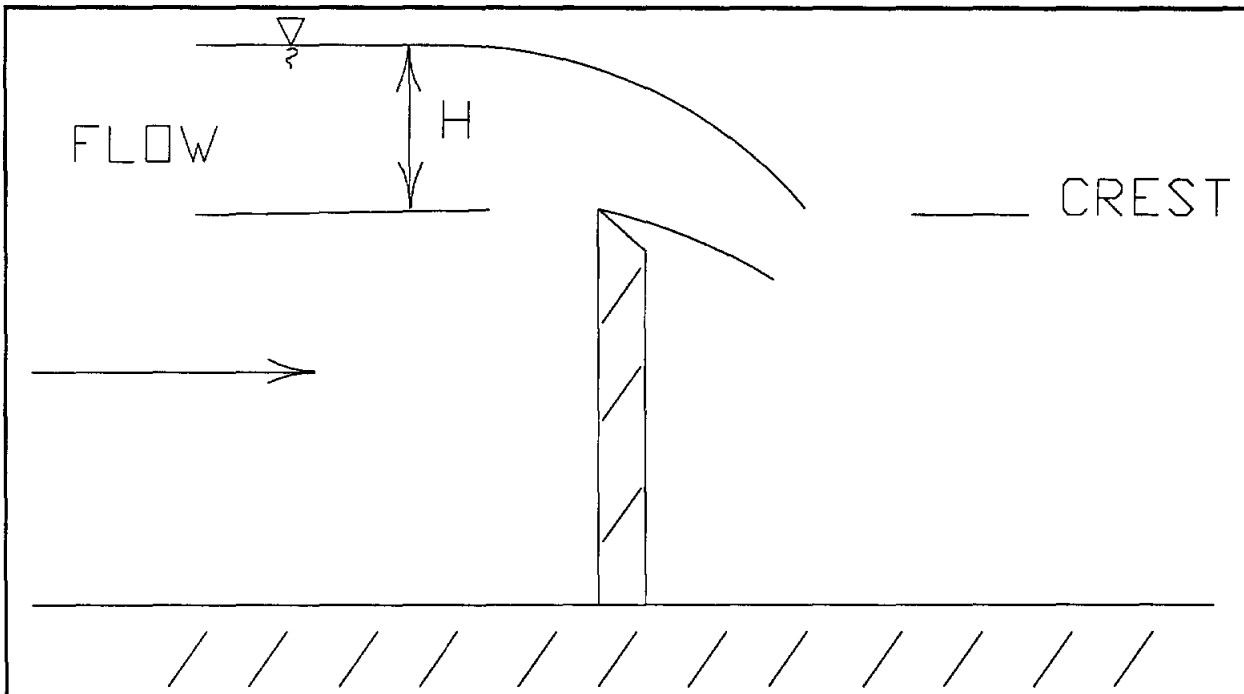

FIGURE 7.8 Section Through Sharp-Crested Weir

The flow capacity of a weir decreases under tailwater conditions high enough to result in **submergence**. Figure 7.9 illustrates the adjustments necessary to account for submergence for various types of weirs.

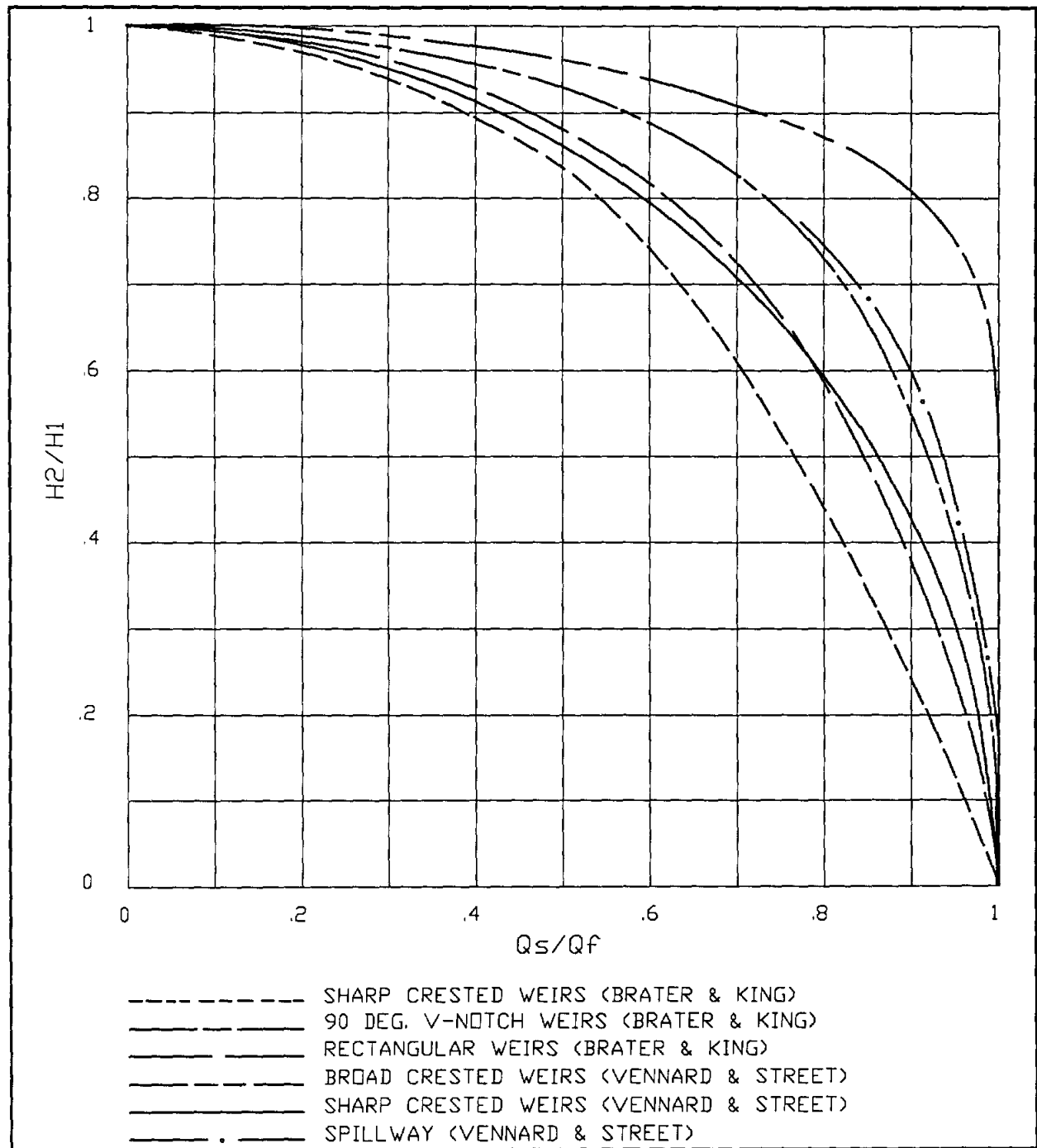

FIGURE 7.9 Capacity Adjustments for Submerged Weirs

7.3.10 V-notch Weir

Figure 7.10 illustrates a V-notch weir. These types of weirs are useful when the flow rate must increase more slowly with each increment of head.

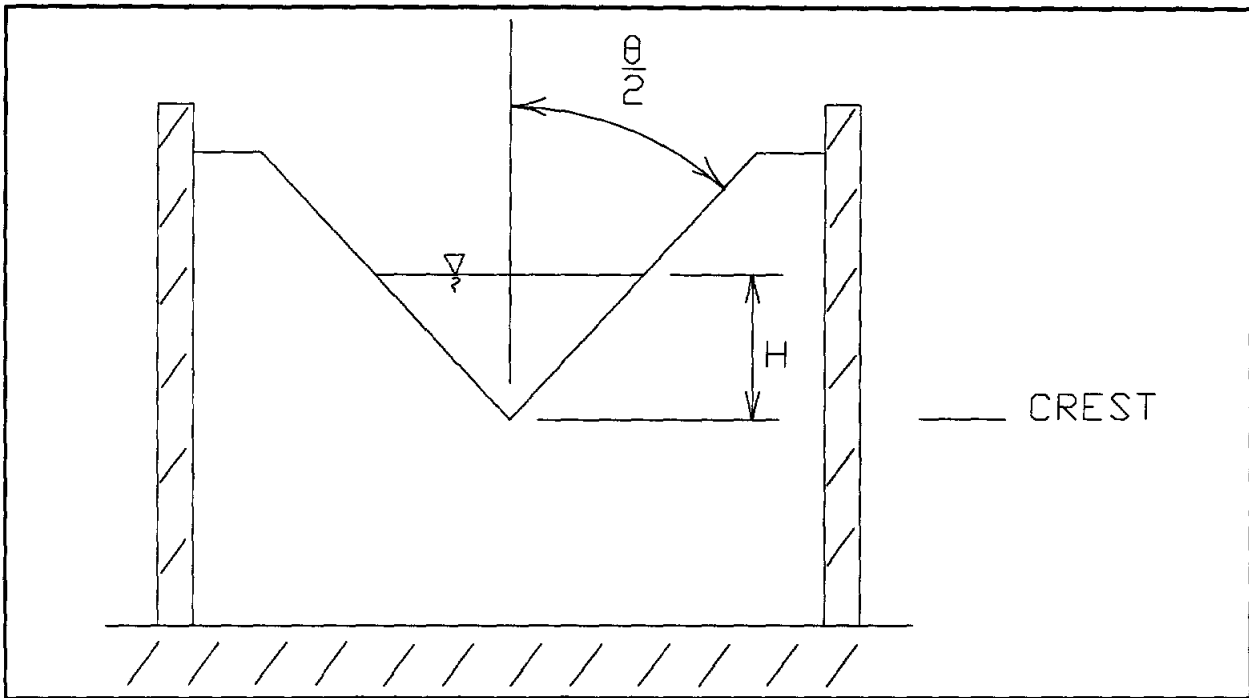

FIGURE 7.10 Sharp-Crested V-Notch Weir

The following equation is used to compute the flow capacity of a V-notch weir:

$$Q = 2.5 \tan \frac{\theta}{2} H^{2.5} \quad \text{Equation 7.5}$$

in which:

Q = the flow capacity of the weir (cfs).

θ = the angle illustrated in Figure 7.10 (radians).

H = the head on the weir (ft), measured from the lowest point in the notch.

7.3.11 Orifices

Orifices may be of any shape and may be used in lieu of pipes under certain conditions. Circular and rectangular orifices are illustrated in Figures 7.11 and 7.12, respectively. Orifices may be submerged or unsubmerged, as illustrated in Figures 7.13 and 7.14.

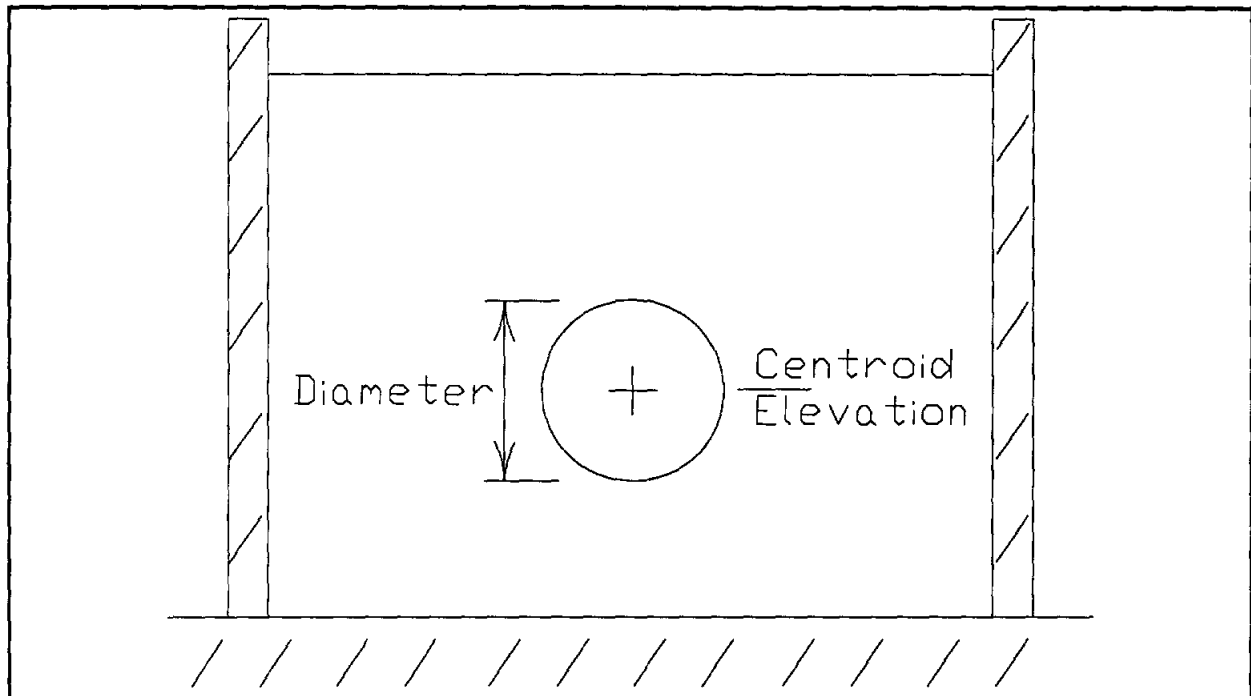

FIGURE 7.11 Circular Orifice

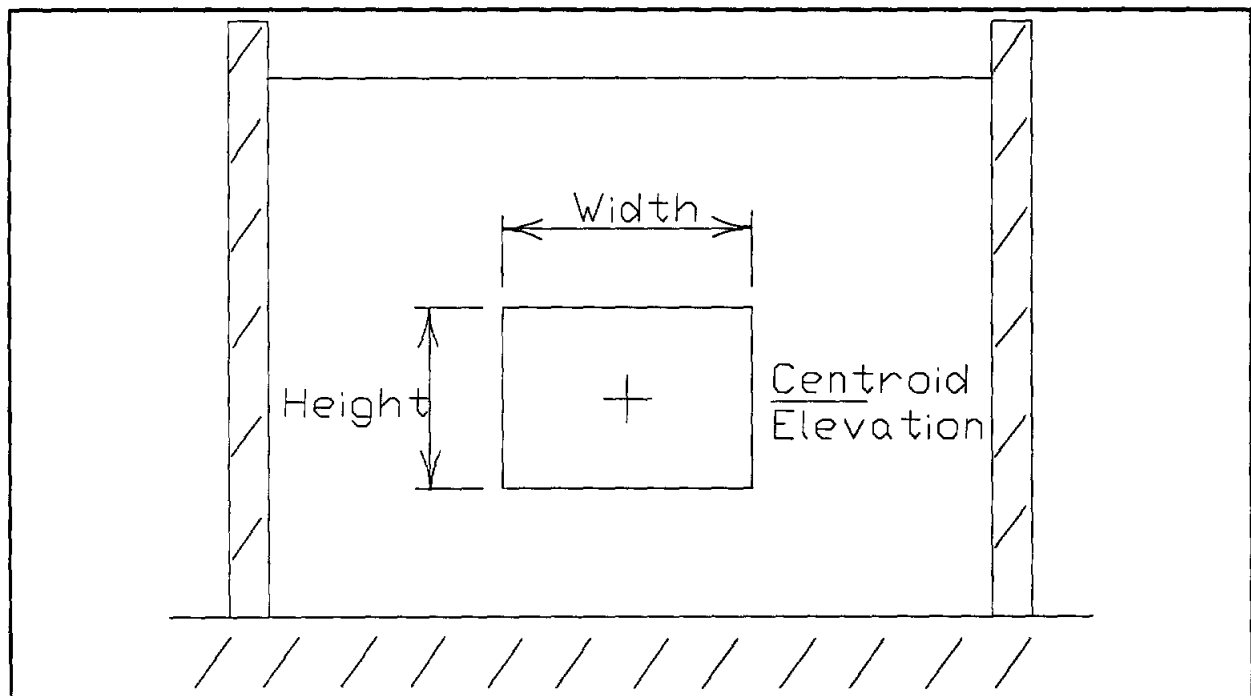

FIGURE 7.12 Rectangular Orifice

The capacity of an unsubmerged orifice may be computed using the following equation:

$$Q = CA\sqrt{2gh_1}$$

Equation 7.6

in which:

Q = the flow capacity of the orifice (cfs).

C = the orifice flow coefficient, which may be determined from most hydraulics textbooks.

A = the cross-sectional area of the orifice (sq ft).

g = acceleration of gravity = 32.2 ft/sec².

h_1 = head on the orifice (ft), measured from the centroid of the cross-sectional area (see Figure 7.13).

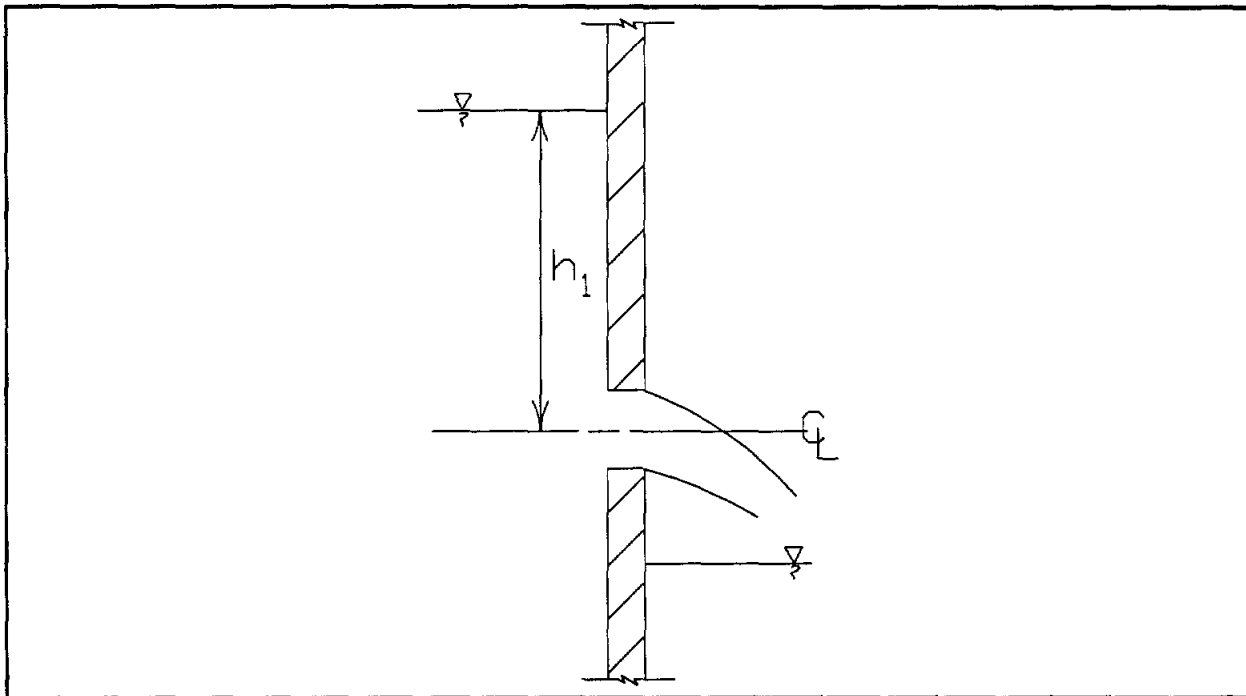

FIGURE 7.13 Unsubmerged Orifice

If the orifice is submerged, the following equation may be used to compute the capacity:

$$Q = CA\sqrt{2g(h_1 - h_2)} = CA\sqrt{2g\Delta h} \quad \text{Equation 7.7}$$

in which:

Q = the flow capacity of the orifice (cfs).

C = the orifice flow coefficient, which may be determined from most hydraulics textbooks.

A = the cross-sectional area of the orifice (sq ft).

g = acceleration of gravity = 32.2 ft/sec².

h_1 = the upstream head on the orifice (ft), measured from the centroid of the cross-sectional area.

h_2 = the downstream head on the orifice (ft), measured from the centroid of the cross-sectional area.

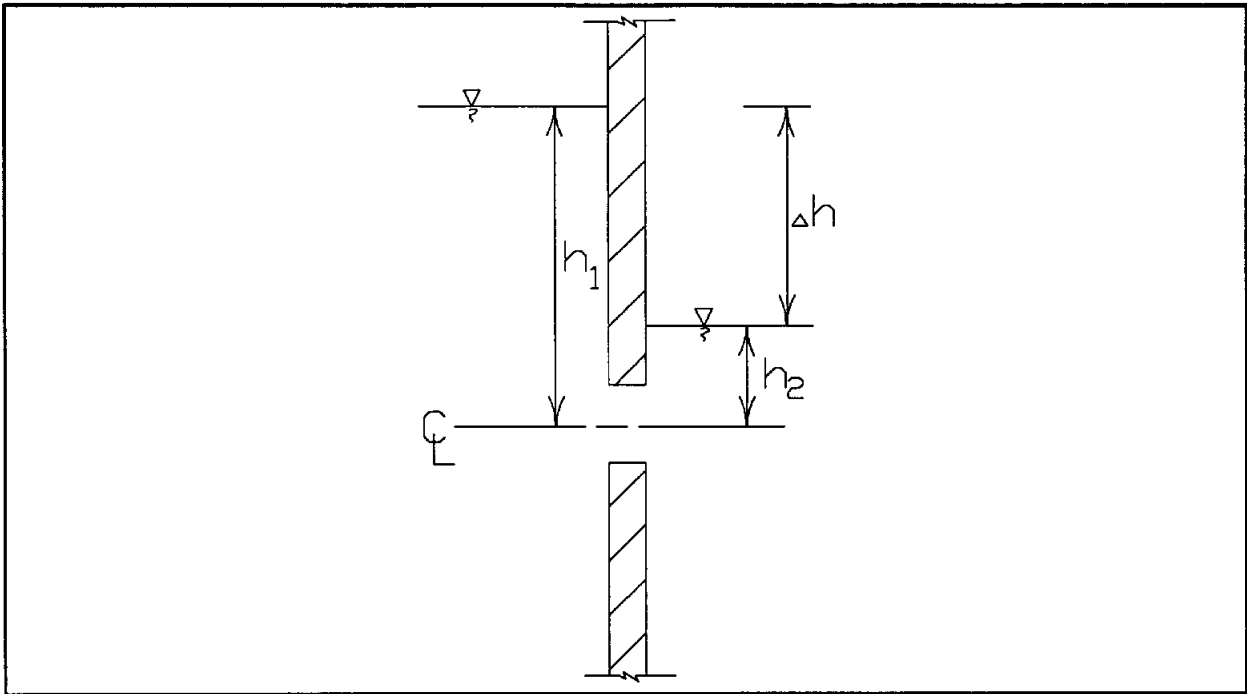

FIGURE 7.14 Submerged Orifice

7.3.12 Pipe spillway with riser

Pipe spillways with risers are useful in certain situations. Figure 7.15 illustrates a typical riser pipe configuration. Hydraulically, the riser pipe acts as a weir as long as the outlet pipe has sufficient capacity to prevent submergence. The riser crest may be analyzed using Equation 7.4 (the weir flow equation). When the riser pipe itself begins to fill, however, the entire structure begins to act as a pressure conduit and should be analyzed using the methods described in SECTION 4.1.9.2.

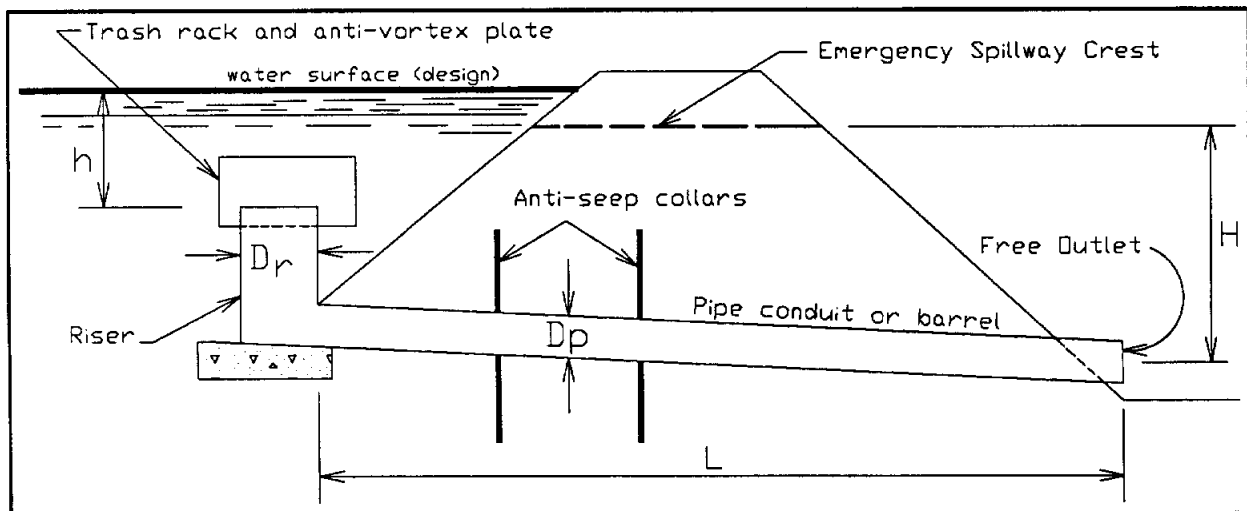

FIGURE 7.15 Pipe Outlet Structure with Drop Structure Inlet

7.3.13 Extreme Event Design

In order to accommodate extreme storm events which are less frequent than the 100-year design storm, an emergency overflow system shall be provided for all detention basins in Montgomery County. This system, which may consist of an overflow swale, a weir, or other structure approved by the Montgomery County Drainage Administrator, shall be designed to carry the 100-year allowable detention basin discharge at full-bank conditions (water surface elevation equal to minimum basin top of bank elevation). The emergency overflow system shall direct flows into an outfall channel and prevent flow in the direction of developed areas.

7.4 PUMP DETENTION FACILITIES

Pumped detention systems will not be maintained by Montgomery County under any circumstances and will be approved for use only under the following conditions (taken from the *Criteria Manual for Design of Flood Control and Drainage Facilities in Harris County, Texas* [HCFCD, 1984] and also applicable to Montgomery County):

- 1) A gravity system is not feasible from an engineering and economic standpoint;
- 2) At least two pumps are provided, each of which is sized to pump the design flow rate; if a triplex system is used, any two of the three pumps must be capable of pumping the design flow rate;
- 3) The selected design outflow rate must not aggravate downstream flooding. (Example: A pump system designed to discharge at the existing 100-year flow rate each time the system comes on-line could aggravate flooding for more frequent storm events).
- 4) Fencing of the control panel is provided to prevent unauthorized operation and vandalism;
- 5) Adequate assurance is provided that the system will be operated and maintained on a continuous basis;
- 6) Emergency source of power is provided.

If a pump system is desired, review of the preliminary conceptual design by the Montgomery County Drainage Administrator is recommended before any detailed engineering is performed.

7.5 GEOTECHNICAL INVESTIGATION

Before initiating final design of a detention pond, a detailed soils investigation by a geotechnical engineer should be undertaken. The following minimum requirements, taken from the *Criteria Manual for Design of Flood Control and Drainage Facilities in Harris County, Texas* [HCFCD, 1984], shall be addressed:

- 1) The ground water conditions at the proposed site;
- 2) The type of material to be excavated from the pond site and its suitability for additional use;
- 3) If a dam is to be constructed, adequate investigation of potential seepage problems though the dam and attendant control requirements, the availability of suitable embankment material and the stability requirements for the dam itself;
- 4) Potential for structural movement or areas adjacent to the pond due to the induced loads from existing or proposed structures and methods of control that may be required;
- 5) Stability of the pond side slopes.

7.6 GENERAL REQUIREMENTS FOR DETENTION POND CONSTRUCTION

The structural design of detention facilities is very similar to the design of open channels. For this reason, all requirements from SECTION 3 pertaining to the design of concrete-lined or grass-lined channels shall also apply to concrete-lined or grass-lined detention facilities.

In addition, the following guidelines taken from the *Criteria Manual for Design of Flood Control and Drainage Facilities in Harris County, Texas* [HCFCD, 1984] are applicable:

- 1) **Pond Bottom:** A pilot channel shall be provided in detention facilities to insure that proper and complete drainage of the storage facility will occur. Concrete pilot channels shall have a minimum depth of two inches and a minimum flow-line slope of 0.0005 ft/ft. Grass-lined pilot channels shall have a minimum depth of two feet, a minimum flow-line slope of 0.001 ft/ft, and maximum side slopes of 3:1.

The bottom slopes of the detention basin should be graded toward the pilot channel at a minimum slope of 0.005 ft/ft, and a recommended slope of 0.0075 ft/ft.

Detention basins which make use of a channel section for detention storage may not be required to have a pilot channel, but should be built in accordance with the requirements for open channels as outlined in SECTION 3.

- 2) **Outlet Structure:** The outlet structure for a detention pond is subject to higher than normal head water conditions and erosive velocities for prolonged periods of time. For this reason the erosion protective measures are very important.

Reinforced concrete pipe used in the outlet structure should conform to ASTM C-76 Class III with compression type rubber gasket joints conforming to ASTM C-443. Pipes, culverts and conduits used in the outlet structures should be carefully constructed with sufficient compaction of the backfill material around the pipe structure as recommended in the geotechnical analysis. Generally, compaction density should be the same as the rest of the structure. The use of pressure grouting around the outlet conduit should be considered where soil types or conditions may prevent satisfactory backfill compaction. Pressure grouting should also be used where headwater depths could cause backfill to wash out around the pipe.

SECTION 8 LEVEED AREAS

Flood plain areas may be developed to the limits of the floodway if a levee system is constructed to protect the area from high water levels on the adjacent watercourse. The components of the levee system shall include an internal drainage system, a levee, a pump station or adequate storage capacity, and a gravity outlet with an outfall channel to the adjacent watercourse. The Montgomery County design criteria for each component are defined in the following sections. The County's minimum design standards shall be governed by the rules and regulations as established by the Federal Emergency Management Agency (FEMA) including any updates as they occur. The engineer is advised to check the current FEMA rules and regulations. Maintenance of these facilities generally will not be the responsibility of Montgomery County.

Figures 8.1 and 8.2 illustrate typical levee arrangements. Figure 8.3 illustrates a typical levee cross-section.

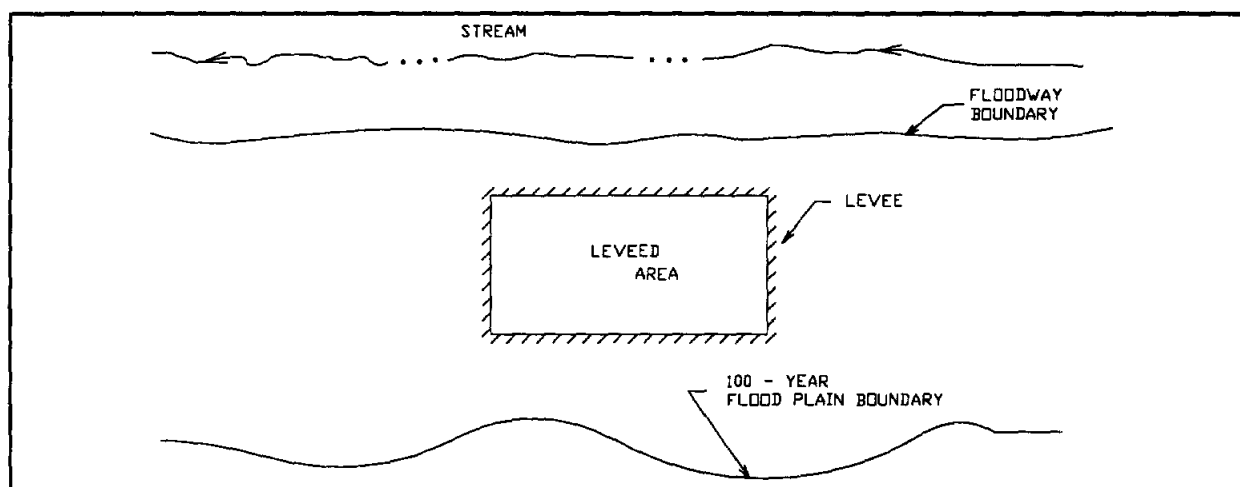

FIGURE 8.1 Typical Layout of Levee Entirely Within Flood Plain

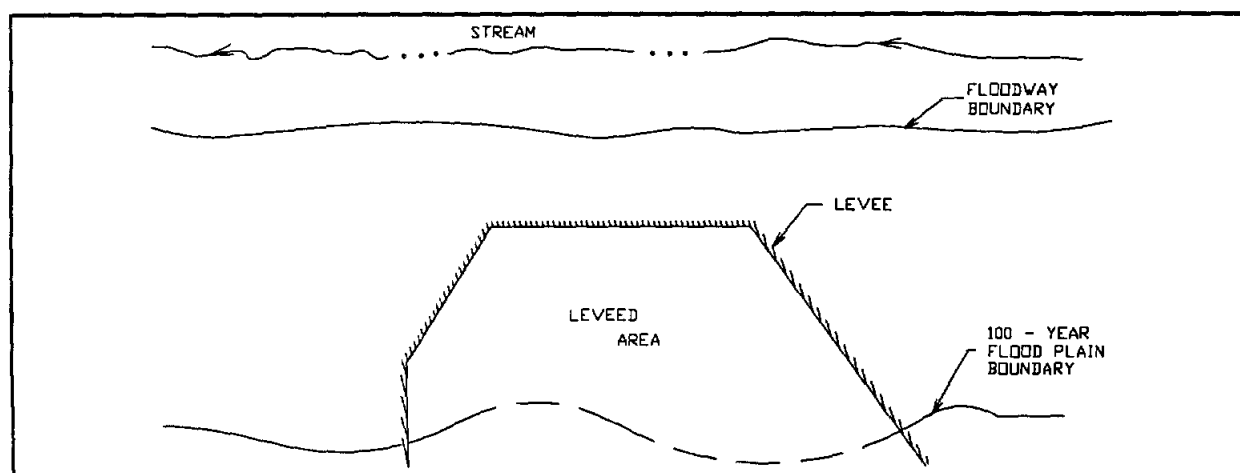

FIGURE 8.2 Typical Layout of Levee Tied into High Ground

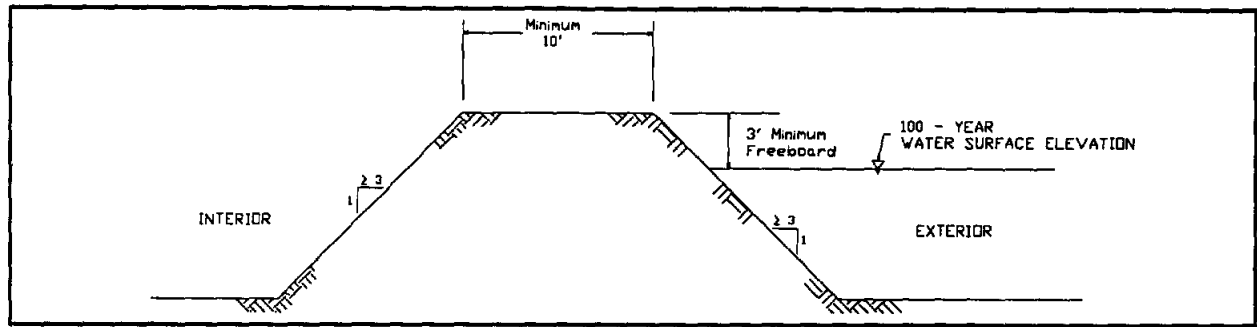

FIGURE 8.3 Typical Levee Cross-Section

8.1 INTERNAL DRAINAGE SYSTEM

The internal drainage system for the levee area shall include the network of channels, lakes, and storm sewers which drain the leveed area to the outfall structure. Refer to SECTION 3 OPEN CHANNELS, SECTION 5 SECONDARY DRAINAGE AND OVERLAND FLOW DESIGN, and SECTION 7 DETENTION DESIGN, for Montgomery County construction requirements and design criteria.

8.2 LEVEE SYSTEM

8.2.1 Frequency Criteria for Levee Systems

The levee system shall include a levee embankment that will protect the development from the 100-year frequency flood event on the adjacent watercourse. Protection from the 100-year frequency event shall include protection from the 100-year water surface elevation on the watercourse, as well as protection from any associated wind and wave action.

8.2.2 Design Criteria for Levee Systems

The following specific criteria and requirements shall apply to the design and construction of a levee in Montgomery County, Texas:

- 1) **Geotechnical Report:** A geotechnical investigation shall be required on the levee foundation (the existing natural ground). Soil borings shall be required with a maximum spacing of 1,000 feet and a minimum depth equal to twice the height of the levee embankment.
- 2) **Foundation:** The foundation area shall be stripped for the full width of the levee. Stripping shall include removal of all grass, trees, and surface root systems.
- 3) **Embankment Material:** Embankment material shall be CH or CL as classified under the Unified Soil Classification System and shall have the following properties:
 - a) Liquid Limit greater than or equal to 30.
 - b) Plasticity Index greater than or equal to 15.
 - c) Percent Passing No. 200 Sieve greater than or equal to 50.

A geotechnical investigation shall be required on the embankment material to determine the levee side slopes and methods employed to control subsurface seepage.

- 4) **Compaction:** The embankment material shall be compacted to a minimum density of 95 percent using the standard proctor compaction test at approximately plus or minus three percent optimum moisture content. The embankment material shall be placed in lifts of not more than 12 inches thick.

- 5) **Erosion Control:** The levee top and side slopes shall be adequately protected by grass cover or other suitable material.
- 6) **Levee Top Width:** The minimum levee top width shall be ten feet.
- 7) **Levee Side Slopes:** The levee side slope shall be one vertical to a minimum of three horizontal.
- 8) **Levee Freeboard:** The minimum top of levee elevation shall be the 100-year water surface elevation on the adjacent watercourse plus three feet of freeboard.
- 9) **Levee Alignment:** The levee shall be continuous and shall either completely encompass the development or tie into natural ground located outside of the limits of the adjacent watercourse's 100-year flood plain.
- 10) **Levee Structures:** All pipes and conduits passing through the levee shall have anti-seep collars, flap gates, and slope protection.
- 11) **Levee Right-of-Way:** The minimum right-of-way for the levee shall be from toe to toe. In addition, the establishment of an easement for maintenance and access, which may be located within the right-of-way, shall be required. Access shall be provided with either a minimum 10-foot easement adjacent to the levee, a minimum 10-foot levee top width or a minimum 10-foot horizontal berm on either side of the levee. A minimum 20-foot wide easement should be established in at least two locations to provide access to the levee right-of-way from a nearby public road.

8.3 PUMP STATION DESIGN

To prevent flooding within leveed areas, pumps are recommended (instead of only storage) to remove interior drainage when the exterior river stage reaches a level that prevents gravity outflow.

8.3.1 Frequency Criteria for Pump Stations

In order to determine the required pump capacity so that the maximum ponding level within the leveed area will not be exceeded on the average more than about once in 100 years, the following design criteria have been developed.

The two sets of criteria provided below differ depending on whether the storm that occurs over the leveed area during high exterior river stages is an independent or dependent event as compared to the storm that produced the high river stages.

If the two events are independent of each other, then a coincident probability relationship exists and the first set of criteria (SECTION 8.3.1.1 Frequency Criteria for Coincident Events) should be utilized. Since high exterior flood stages requiring the pumping of interior drainage can exist independent of rainfall occurring over the leveed area, the probability of these two independent severe storm events occurring at the same time is much smaller than their individual probabilities. As a result, the design rainfall used in determining the required pumping capacity can be reduced below the design 100-year frequency rainfall by an amount related to the frequency that flood stages in the receiving watercourse impede gravity outflow.

If the two events are dependent (i.e. they result from the same storm event), the second set of criteria (SECTION 8.3.1.2 Frequency Criteria for a Single Event) based on the design 100-year frequency rainfall should be utilized.

8.3.1.1 Frequency Criteria for Coincident Events

These criteria presume that the storm event causing a high flood stage outside of the leveed area is independent of the storm event occurring over the leveed area. The following steps should be taken for determining the required pumping capacity:

- 1) **100-Year Interior Ponding Level:** Select the maximum ponding level within the leveed area that should not be exceeded more than once in 100 years on the average. Normally, this level will be equal to the maximum water surface elevations associated with the 100-year flood event computed in designing the internal drainage system (channels) of the leveed area, including the required minimum freeboard of one foot. This will be the level which, when equalled or exceeded by exterior flood stages, will prevent gravity outflow and require total pumping to remove any runoff that might occur within the leveed area.
- 2) **Corresponding Exterior Discharge:** From a rating or backwater curve applicable to the location on the watercourse where the gravity outflow point of the leveed area exists, determine the discharge corresponding to the maximum ponding level.
- 3) **Coincident Frequency:** Determine the percentage of time that the discharge (obtained from Step 2 above) is equalled or exceeded. Given this percentage of time, determine the frequency of the rainfall event corresponding to the coincident probability of these two events.
- 4) **Corresponding Rainfall:** Use TP-40 [Hershfield, 1961] or other appropriate rainfall frequency curve to obtain the rainfall amounts associated with the return period (obtained from Step 3 above) to be used for determining the required pumping capacity.

8.3.1.2 Frequency Criteria for a Single Event

This criteria presumes the storm event causing high flood stages outside of the leveed area is the same (dependent) storm event occurring over the leveed area. The design rainfall amounts to be used for sizing the required pump capacity will be associated with the 100-year rainfall event. (See Table 2.3 for rainfall amounts derived from TP-40 [Hershfield, 1961] and Hydro-35 [Frederick, 1977].)

8.3.2 Design Criteria for Pump Stations

All leveed areas within Montgomery County that are equipped with a pump station shall be capable of maintaining the design pumping capacity with its largest single pump inoperative. The capacity of a pump station designed under SECTION 8.3.1.1 Frequency Criteria for Coincident Events shall be adequate to remove a minimum volume of water from the leveed area within 24 hours without exceeding the maximum ponding elevation within the leveed area. If a pump station is not provided, adequate storage volume below the maximum ponding level must be provided to contain the entire design storm. The volume of runoff to be pumped shall be the greater of either:

- 1) The runoff resulting from the appropriate rainfall amount as determined in Step 4 of SECTION 8.3.1.1 Frequency Criteria for Coincident Events.
- 2) A minimum of 1.5 inches of runoff from fully developed areas and 1 inch of runoff from undeveloped areas over the contributing watershed.

A pump station designed under SECTION 8.3.1.2 Frequency Criteria for a Single Event shall have a combination of storage volume and pumping capacity adequate to maintain the runoff resulting from the 100-year frequency event below the maximum ponding level. The minimum pumping capacity shall be the same as number two above. All pump stations in Montgomery County shall be equipped with auxiliary power for emergency usage.

8.4 GRAVITY OUTLET AND OUTFALL CHANNEL

An outlet shall be required to release the gravity flow from the leveed area through the outfall channel to the adjacent watercourse during low flow conditions on the receiving channel. The outlet shall be equipped with an automatically functioning gate to prevent any external flow from entering the leveed area. This gate should also be accessible for manual operation during periods of high water.

The outlet and outfall channel shall be designed in accordance with the criteria stated in SECTION 3 OPEN CHANNELS. The velocities within the outfall all channel at the adjacent river shall not exceed 5.0 feet per second.

SECTION 9 FLOOD PLAIN DEVELOPMENT AND WATERSHED ANALYSIS

This section presents information concerning requirements for development in the 100-year flood plain and methods for evaluating the potential impact of development on flood plain levels.

9.1 DEVELOPMENT IN THE 100-YEAR FLOOD PLAIN

The following paragraphs present information concerning the regulations for development in the 100-year flood plain, and the procedures and methods of evaluating the feasibility of flood plain development and obtaining approval for such a development.

9.1.1 Flood Plain Regulations

Development within the 100-year flood plain in the unincorporated areas of Montgomery County is regulated by the Montgomery County Drainage Administrator. All areas within an incorporated municipality are subject to the regulation of that municipality.

The Montgomery County regulations place controls on the type and location of new construction within a designated 100-year flood plain and floodway. The **100-year flood plain** is the area adjacent to a stream or watercourse which, on the average, has at least a one percent chance of being inundated from flood waters in any given year. The **100-year floodway** is the channel and adjacent area which is required to carry and discharge the 100-year peak flow rate. Based on the current Federal Emergency Management Agency criteria, the 100-year floodway is determined based on the assumption of an equal loss of conveyance (flow-carrying capacity) along both sides of the stream resulting in a one-foot increase in the 100-year flood plain elevation along the entire length of the watercourse. A schematic cross section defining the flood plain and floodway is presented on Figure 9.1.

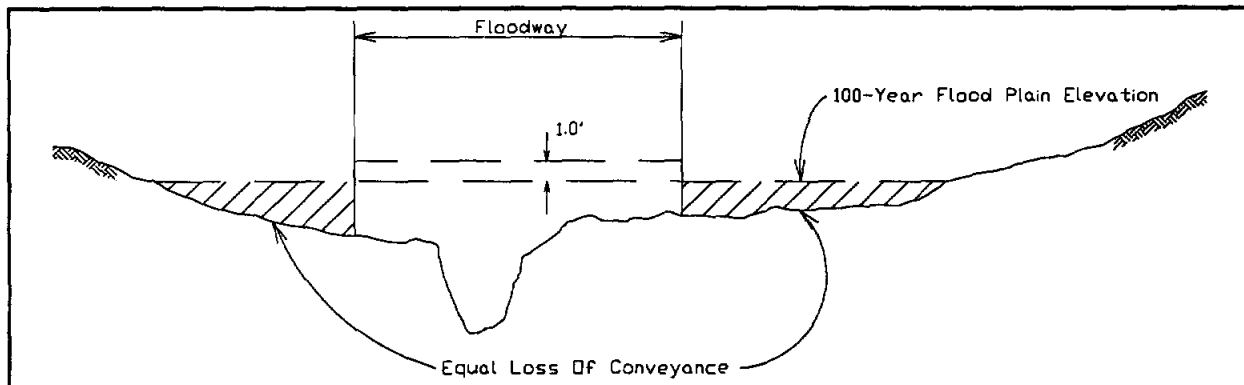

FIGURE 9.1 100-Year Flood Plain and Floodway

A detailed discussion of the Montgomery County regulations is beyond the scope of this manual. However, the following items describe in general the more important engineering aspects of the regulations concerning development within the 100-year flood plain:

- 1) The lowest floor of any new construction in flood plain areas must be above the 100-year flood elevation.
- 2) No fill or encroachment is permitted within the 100-year floodway which will impair its ability to discharge the 100-year peak flow rate except where the effect on flood heights has been fully offset by stream improvements.

- 3) Placement of fill material within the flood plain requires a permit from the County Drainage Administrator. Appropriate fill compaction data and hydrologic and hydraulic data are required before a permit will be issued.

9.1.2 Flood Plain Development Guidelines and Procedures

The following guidelines should be followed when planning a development within the 100-year flood plain.

- 1) The development plan should provide for adequate passage through the development of flood waters associated with the adjacent waterway. Wherever possible, streets and other open areas such as parking lots and recreational areas should be oriented to allow these areas to act as conveyance routes for the flood flows associated with the adjacent waterway.
- 2) Land fill within the flood plain should be minimized and the importation of fill material from outside of the flood plain is discouraged. When fill is used, conveyance improvements must be provided to offset any increase in flood levels.
- 3) Construction within the floodway is limited to structures which will not obstruct the 100-year flood flow unless fully offsetting conveyance capacity is provided.
- 4) Although current regulations allow encroachment within the flood plain to the floodway limit, consideration must be given to the resulting effect of the encroachment on flood levels in the stream and to the potential for increased flood damage. Where such a potential exists, offsetting conveyance capacity must be provided to eliminate the increased potential for flood damage.

Specific procedures to be followed for analysis of development proposed within the flood plain are outlined below:

- 1) The existing designated 100-year flood plain and floodway should be plotted on a map of the proposed development. The designated flood levels and floodway may be obtained from the Montgomery County Drainage Administrator.
- 2) A hydraulic profile should be developed utilizing the HEC-2 computer program or other acceptable hydraulic modeling technique which provides a reasonable comparison with the designated flood levels and floodway.
- 3) The effect of the proposed development and the encroachment into the flood plain area, should be incorporated into the hydraulic model and the resulting flood plain determined. Careful consideration should be given to providing an accurate modeling of effective flow areas taking into account the expansion and contraction of the flow.
- 4) The required channel improvements or other means of offsetting increases in flood plain elevations should then be incorporated into the hydraulic model. The resulting flood levels should be determined to verify that the improvements sufficiently offset the encroachment.
- 5) Once it has been determined that the proposed improvements adequately offset the encroachment, a revised floodway for the stream must be computed and delineated.
- 6) All hydraulic model data should be submitted with appropriate supporting information and computations to the Montgomery County Drainage Administrator for review.

9.2 DOWNSTREAM IMPACT ANALYSIS

Pursuant to the official policy for Montgomery County, development will not be allowed in a manner which will increase the frequency or severity of flooding in areas that are currently subject to flooding or which will cause areas to flood which were not previously subject to flooding. The task of determining what downstream areas may be impacted by a proposed development is not an easy one. Varying rainfall patterns over a watershed and changing land-use conditions in other areas of the watershed may affect the extent and area of impact due to a proposed development. Also, developments of a similar nature located in different parts of a watershed may have different

downstream impacts. Because of these various factors and uncertainties, the criteria outlined below are general in nature. Specific projects should be closely coordinated with the Montgomery County Drainage Administrator from their outset in order to avoid costly revisions and delays in project completion.

The following are generally recommended criteria and procedures to be followed:

- 1) The location of the proposed project should be submitted by the project engineer to the Montgomery County Drainage Administrator for comment.
- 2) The Montgomery County Drainage Administrator will indicate the downstream areas which it considers to be of concern with respect to the potential, impact of the proposed project.
- 3) The project engineer will then determine the impact on the areas of concern and present data to satisfy the Montgomery County Drainage Administrator that no adverse impact will result.

9.2.1 Acceptable Alternative Courses of Action

To satisfy the Montgomery County Drainage Administrator that no adverse impact will result, three potential courses of action may be followed:

- 1) Provide channel improvements through the area of concern which fully offset the increased flow rates caused by the proposed development, or;
- 2) A detention basin or other acceptable detention system may be designed to eliminate any increase in peak flow rates to the receiving stream, or;
- 3) A flood routing study may be performed which shows that the proposed project will not increase peak flow rates through the critical area under reasonable assumptions regarding rainfall distribution and land use within the watershed.

These three alternative courses of action are not intended to be mutually exclusive. A combination of solutions involving these approaches may be obtained. For example, a combination of some downstream channel improvements and detention storage may be used. A detailed routing study may show that the proposed development may increase downstream flow rates to a minor extent which may be compensated for by minor channel improvements or a small detention system. However, in lieu of a detailed routing study; the design of offsetting channel improvements or detention will be based on the assumption that the peak runoff rate from the proposed development occurs at the same time as the peak runoff rate for the receiving stream through the critical reach. The design of improvements under items (1) and (2) above shall follow the procedures described in the applicable sections of this manual.

9.2.2 Flood Routing Studies

Regarding routing studies to evaluate the impact on downstream critical reaches, the following general guidelines shall be followed:

- 1) Rainfall distribution over the watershed shall be in accordance with this manual. However, the Montgomery County Drainage Administrator may require additional analyses under different rainfall assumptions if the County Drainage Administrator feels such analyses are warranted.
- 2) Channel improvements planned to be completed within a two-year period may be considered in the routing procedures.
- 3) Future land-use conditions within the watershed to be used in the routing study shall be defined by the Montgomery County Drainage Administrator.

- 4) Unless an alternative method is specifically approved by the Montgomery County Drainage Administrator, the Corps of Engineers' HEC-1 program shall be utilized for performing the routing analysis. The hydrologic methodology for Montgomery County presented in this manual is recommended. Optional routing methodologies should be reviewed with the Montgomery County Drainage Administrator. Sub-area runoff computations and associated routing shall be performed on sub-areas which are of a size that allow reasonable determination of the timing of flows from the development in comparison with the overall timing of flood flows from the watershed. The sub-area breakdown, hydrograph coefficients, routing methodology, etc. should be submitted to the Montgomery County Drainage Administrator for approval prior to performing detailed calculations.

**SECTION 10
BIBLIOGRAPHY**

- American Public Works Association (APWA), *Urban Stormwater Management*, Special Report No. 49, 1981.
- ????, *Urban Storm Drainage Criteria Manual*, 1969. This is the source of the rational method frequency factor adjustment used in this manual.
- Bradley, J. N., *Hydraulics of Bridge Waterways*, Federal Highway Administration, Hydraulic Design Series Document No. 1, 1970.
- Chow, Ven Te, (Ed.), *Handbook of Applied Hydrology*, McGraw-Hill Book Company, New York, 1964. This book provides information on many aspects of hydrology and hydraulics, especially unit hydrograph theory.
- Chow, Ven Te, David R. Maidment, and Larry W. Mays, *Applied Hydrology*, McGraw-Hill Book Company, New York, 1988. This is an excellent reference on many of the computational methods used in current hydrology.
- Chow, Ven Te, *Open-Channel Hydraulics*, McGraw-Hill Book Company, New York, 1959. This book is a standard reference on stream channel hydraulics.
- City of Austin, *Drainage Criteria Manual*, Austin, Texas, undated.
- City of Houston, *General Design Requirements for Sanitary Sewers, Storm Sewers, Water Lines and Paving*, Houston, Texas, 1983.
- City of Houston, *Specifications for Sewer Construction*, Form E-14-62, Department of Public Works, Houston, Texas, 1980.
- City of Waco, Texas, *Storm Drainage Design Manual*, Waco, Texas, 19??.
- Dodson & Associates, Inc., *The Dodson Hydraulics Library*, Project No. 9110, Document No. 86/031, Houston, TX, 1986. This software package can perform culvert and channel hydraulic analyses.
- Espey, Huston & Associates, Inc. (EHA), *Drainage Criteria Manual for Fort Bend County, Texas*, Houston, Texas, November, 1987.
- Federal Highway Administration (FHWA), *Hydraulic Design of Highway Culverts*, U.S. Department of Transportation, Federal Highway Administration, Hydraulic Design Series No. 5, September 1985. This publication combines information and methodology contained Hydraulic Engineering Circular (HEC) No. 5, *Hydraulic Charts for the Selection of Highway Culverts*, HEC Number 10, *Capacity Charts for the Hydraulic Design of Highway Culverts*, and HEC Number 13, *Hydraulic Design of Improved Inlets for Culverts* with other more recent culvert information developed by governmental agencies, universities, and culvert manufacturers. The culvert analysis nomographs in Appendix A of this manual are taken from this publication.
- Frederick, Ralph H., et al, *Five- to 60-Minute Precipitation Frequency for the Eastern and Central United States*, Hydro-Meteorological Report No. 35, NOAA, National Weather Service, Silver Spring, Maryland, 1977. This document provides much of the precipitation information required for performing a hypothetical storm computation using the HEC-1 computer program.
- Harris County Flood Control District (HCFCD), *Criteria Manual for the Design of Flood Control and Drainage Facilities in Harris County, Texas*, Houston, Texas, February, 1984.
- Harris County Flood Control District (HCFCD), *Hydrology for Harris County*, Seminar Notebook, March 1988.

- Hershfield, David M., *Rainfall Frequency Atlas of the United States for Durations from 30 Minutes to 24 Hours and Return Periods from 1 to 100 Years*, Technical Paper No. 40, Weather Bureau, U. S. Department of Commerce, Washington, D.C., 1961. This document provides much of the precipitation information required for performing a hypothetical storm computation using the HEC-1 computer program.
- Hydrologic Engineering Center (HEC), *HEC-1 Flood Hydrograph Package Users Manual*, U.S. Army Corps of Engineers, Hydrologic Engineering Center, Davis, CA, March 1987 (with addendum dated June 1988).
- Hydrologic Engineering Center (HEC), *HEC-2 Water Surface Profiles Users Manual*, U.S. Army Corps of Engineers, Davis, CA, September 1982.
- Hydrologic Engineering Center (HEC), *Hydrologic Analysis of Ungaged Watersheds Using HEC-1*, Training Document No. 15, U.S. Army Corps of Engineers, Hydrologic Engineering Center, Davis, CA, April 1982. This is an excellent guide to the hydrologic methods used by the HEC-1 program in performing runoff computations.
- Linsley, Ray K. And Joseph B. Franzini, *Water Resources Engineering*, McGraw-Hill, Inc., New York, 1979.
- Malcom, H.R., *A Study of Detention in Urban Stormwater Management*, Report No. 156, Water Resource Research Institute of the University of North Carolina.
- McCuen, Richard H., *A Guide to Hydrologic Analysis Using SCS Methods*, Prentice-Hall, Inc., Englewood Cliffs, N.J., 1982. This document provides background information on the Soil Conservation Service dimensionless unitgraph and the SCS Curve Number approach for computing infiltration losses.
- Miller, John F., *Two- to Ten-Day Precipitation for Return Periods of 2 to 100 Years in the Contiguous United States*, Technical Paper No. 49, Weather Bureau, U. S. Department of Commerce, Washington, D.C., 1964. This document provides much of the precipitation information required for performing a hypothetical storm computation using the HEC-1 computer program.
- Pate Engineers, Inc. (Pate), *San Jacinto River Authority Water Resources Development Plan, Volume II - Flood Control*, Houston, Texas, June 1988 (Draft).
- Schaeffer, John R., et al, *Urban Storm Drainage Management*, Marcel Dekker, Inc., New York, 1982.
- Soil Conservation Service, *SCS National Engineering Handbook, Section 4: Hydrology*, Superintendent of Documents, U.S. Government Printing Office, Washington, D.C. 20402, August 1972. This document provides background information on the SCS Curve Number approach for computing infiltration losses.
- Soil Conservation Service, *TR-20, Project Formulation - Hydrology (1982 Version) Technical Release No. 20*, Soil Conservation Service, Lanham, MD, 1982. This document provides background information on the SCS Curve Number approach for computing infiltration losses.
- Soil Conservation Service (SCS), *Soil Survey of Montgomery County, Texas*, United States Department of Agriculture, October 1972.
- Soil Conservation Service (SCS), *Urban Hydrology for Small Watersheds*, Technical Release 55, U.S. Department of Agriculture, 1986
- Texas Department of Highways and Public Transportation (TDHPT), *Hydraulic Manual*, 3rd Edition, Bridge Division, Austin, TX, December 1985.
- Texas Water Commission (TWC), *Title 31 Texas Administrative Code*, Chapter 299, Austin, Texas, May 1986. Sub-chapters A through E classify dam sizes and hazard potential and specify required failure analyses and spillway design flood criteria.

- Transportation Research Board (TRB), *Design of Sedimentation Basins*, National Cooperative Highway Research Program Report No. 70, National Research Council, Washington, D.C., June 1980.
- Turner, Collie & Braden, Inc. (TCB), *Harris County Flood Hazard Study Final Report*, Houston, Texas, September 1984.
- U.S. Army Corps of Engineers (USACE), *Hydraulic Design of Flood Control Channels*, EM 1110-2-1601, July 1970.
- U.S. Army Corps of Engineers Galveston District, *Harris County Flood Insurance Study, Hydrologic Data for Spring Creek and Surrounding Watersheds*, Galveston, Texas, June 1977.
- U.S. Army Corps of Engineers Galveston District, *Harris County Flood Insurance Study, Revised Hydrologic Data for Rural Watersheds*, Galveston, Texas, June 1977.
- U.S. Army Corps of Engineers Galveston District, *Lake Creek Study Report: Hydrology and Hydraulics*, Galveston, Texas, July 1986.
- U.S. Bureau of Reclamation (USBUREC), *Design of Small Dams*, 2nd Ed., U.S. Government Printing Office, 1972.
- U.S. Bureau of Reclamation (USBUREC), *Hydraulic Design of Stilling Basins and Energy Dissipators*, Engineering Monograph No. 25, U.S. Department of the Interior, May 1984.
- U.S. Bureau of Reclamation (USBUREC), Progress Report V - *Research Study on Stilling Basins, Energy Dissipators, and Associated Appurtenances*, Section 9, Hydraulic Laboratory Report No. Hyd-445, U.S. Department of the Interior, April 28, 1961.
- Wayne Smith & Associates, Inc. (Smith), *San Jacinto Upper Watershed Drainage Improvement and Flood Control Study*, Houston, Texas, July 1985.

INDEX

- 100-Year Design Storm
 - Culverts, 53
- 100-Year Flood Plain
 - Definition, 133
- 100-Year Floodway
 - Definition, 133
- 100-Year Storm
 - Channel Design, 42
 - Storm Sewers and Overland Flow, 82
- 24-Hour Storm
 - Channel Design, 42
- 24-Hour Storm Event
 - HEC-1 Computer Program, 25
- Abstractions
 - HEC-1 Computer Program, 27
- Adjustment for Ponding, 30
- Aesthetic Considerations
 - Detention Basins, 112
- Alignment
 - Bridges, 64
 - Culverts, 53
 - Levee Systems, 129
 - Storm Sewers, 74
- Antecedent Precipitation
 - Rational Method, 5
- Approval
 - Montgomery County Engineer, 1, 37
- Approval of Variances
 - Montgomery County Drainage Administrator, 1
- Appurtenant Storm Sewer Structures, 76
- ASSHTO HS20-44, 54
- ASTM 850-79, 54
- ASTM A-760, 54
- ASTM C-76, 54
- ASTM C789-79, 54
- Attenuation, 31
- Average Channel Slope, 30
- Average Watershed Slope, 30
- Backfill
 - Culverts, 56
- Backslope Drainage Systems
 - Design Depth, 103
 - Erosion Control, 103
 - General Requirements, 103
 - Grade, 103
 - Location, 103
 - Maximum Drain Spacing, 103
 - Minimum Pipe Size, 103
 - Side Slope, 103
- Backslope Drains
 - Concrete-Lined Channels, 46
- Baffled Chutes
 - Design Procedure, 97
 - Erosion Control, 97
- Bedding
 - Culverts, 56
- Benchmark Information
 - Required for Open-Channel Design, 42
- Bends
 - Water Surface Profile Computations, 50
- Bottom
 - Detention Basins, 125
- Bottom Slope
 - Rectangular Concrete Pilot Channels, 46
- Bottom Width
 - Concrete-Lined Channels, 46
 - Grass-Lined Channels, 45
 - Open-Channel Design, 43
 - Rectangular Concrete Pilot Channels, 46
 - Roadside Ditches, 81
- Box Culverts
 - Structural Requirements, 54
- Bridges
 - Alignment, 64
 - Channel Erosion Control, 44
 - Design Storm Frequency, 64
 - Erosion Control, 65
 - Hydraulic Design, 65
 - Length, 64
 - Minimum Low Chord Elevation, 65
 - Piers and Abutments, 65
- Bridges and Culverts
 - Water Surface Profile Computations, 51
- Bureau of Reclamation Unitgraph, 20
- Celerity of Gravity Waves, 37
- Chance, Ed, 2
- Channel Bends
 - Channel Erosion Control, 44
 - Erosion Control, 86
 - Open-Channel Design, 44
 - Radius of Curvature, 44
 - Water Surface Profile Computations, 50
- Channel Bottom Slope
 - Rectangular Concrete Pilot Channels, 46
- Channel Bottom Width
 - Concrete-Lined Channels, 46
 - Grass-Lined Channels, 45
 - Open-Channel Design, 43
 - Rectangular Concrete Pilot Channels, 46
- Channel Confluences
 - Angles of Intersection, 44
 - Channel Erosion Control, 44
 - Erosion Control, 85
 - Open-Channel Design, 44
- Channel Cross-Section Data Points
 - Water Surface Profile Computations, 49
- Channel Cross-Section Orientation
 - Water Surface Profile Computations, 48
- Channel Cross-Section Spacing
 - Water Surface Profile Computations, 49
- Channel Cross-Sections
 - Required for Open-Channel Design, 42
- Channel Design

- Consideration of Storm Sewers, 42
- Downstream Effects of Improvements, 42
- Required Documentation, 42
- Storm Frequencies, 42
- Channel Drop Structures
 - Open-Channel Design, 43
- Channel Erosion Control
 - Bridges, 44
 - Channel Bends, 44
 - Channel Confluences, 44
 - Grass-Lined Channels, 45
 - Sheet Flow, 44
 - Soils Conditions, 44
 - Steep Channel Sections, 44
- Channel Erosion Protection
 - Open-Channel Design, 44
- Channel Friction Losses
 - Water Surface Profile Computations, 49
- Channel Improvements
 - Downstream Effects, 42
 - Flood Plain Areas, 134
- Channel Maintenance
 - Open-Channel Design, 44
- Channel Mowing Equipment
 - Open-Channel Design, 43
- Channel Profile
 - Required for Open-Channel Design, 42
- Channel Right-of-Way
 - Channel Maintenance, 44
 - Concrete-Lined Channels, 46
 - Grass-Lined Channels, 45
- Channel Right-of-Way Requirements, 48
- Channel Routing
 - HEC-1 Computer Program, 31
- Channel Side Slope
 - Grass-Lined Channels, 44
- Channel Side Slopes
 - Open-Channel Design, 43
- Channel Slope, 30
 - Open-Channel Design, 43
- Channel Stationing
 - Water Surface Profile Computations, 49
- City of Austin, 53
- City of Houston Curves
 - Storm Sewer or Overland Flow, 68
- Clark Unit Hydrograph
 - HEC-1 Computer Program, 28
- Clark Unit Hydrograph Method, 3
- Class A Concrete
 - Concrete-Lined Channels, 45
 - Rectangular Concrete Pilot Channels, 46
- Class A Low Flow
 - Bridges, 65
- Class B Low Flow
 - Bridges, 65
- Class C Low Flow
 - Bridges, 65
- Clay Soils
 - Flow Velocities, 43
- Coincident Frequency Analysis
 - Levee Systems, 129
- Compaction
 - Levee Systems, 128
- Composite Manning Roughness Coefficient, 30
 - Example Computation, 32
- Composite Roughness Coefficient
 - Computation, 41
- Composite Runoff Coefficients
 - Rational Method, 5
- Concrete-Lined Channels
 - Manning Roughness Coefficient, 43
- Concrete-Lined Trapezoidal Channels
 - Minimum Requirements, 45
- Concrete Box Culverts
 - Structural Requirements, 54
- Concrete Lined Channels
 - Flow Velocities, 43
- Concrete Pipe
 - Storm Sewers, 73
- Concrete Pipe Culverts
 - Structural Requirements, 54
- Concrete Slope Paving
 - Erosion Control, 88
- Confluences of Channels
 - Erosion Control, 85
- Construction
 - Erosion or Sediment Control, 107
- Contractions and Expansions
 - Open-Channel Design, 44
- Control Joints
 - Concrete-Lined Channels, 46
 - Rectangular Concrete Pilot Channels, 47
- Corrugated Metal
 - Culverts, 54
- Critical Depth, 37
 - Culverts, 59
 - Equation for Trapezoidal Channels, 38
- Critical Flow, 37
- Critical Storm Duration
 - Rational Method, 4
- Critical Time of Concentration
 - Rational Method, 6
- Cross-Section Plots
 - Required for Open-Channel Design, 42
- Cul-de-sac Streets
 - Overland Flow, 78
- Culverts, 53
 - Alignment, 53
 - Backfill, 56
 - Bedding, 56
 - Corrugated Metal Pipe Culverts, 54
 - Design Procedure, 59
 - Design Storm Frequency, 53
 - Detention Basins, 117
 - Entrance Loss Coefficients, 57
 - Erosion Control, 88
 - Erosion Protection, 54
 - Example of Design Procedure, 62
 - Exit Loss, 57
 - Guardrails, 54
 - Headwalls and Endwalls, 53
 - Headwater, 56
 - Inlet Control Hydraulics, 56

- Joint Sealant, 56
- Loading, 54
- Manning Roughness Coefficient, 54
- Minimum Sizes, 54
- Outlet Control Hydraulics, 56
- Required Length, 53
- Structural Requirements, 54
- Tailwater Depth, 56
- Typical Cross-Section, 55
- Typical Outlet, 55
- Typical Profile, 55
- Curves in Roadways
 - Overland Flow, 79
- Depth Requirements
 - Roadside Ditches, 81
- Design Documentation
 - Detention Basins, 113
- Design Flow
 - Roadside Ditches, 81
- Design Rainfall Duration
 - Rational Method, 6
- Design Storm Frequency
 - Bridges, 64
 - Culverts, 53
 - Detention Basins, 113
 - Levee Systems, 128
 - Levee Systems Pump Stations, 129
 - Storm Sewer or Overland Flow, 67
 - Storm Sewers, 74
- Detention Basins
 - Aesthetic Considerations, 112
 - Design of Large Facilities, 116
 - Design of Outlet Structure, 125
 - Design of Pond Bottom, 125
 - Design of Small Basins, 114
 - Design Storm Frequency, 113
 - Discharge Calculations, 114
 - Erosion Control, 113
 - Extreme Event Design, 124
 - Extreme Storm Events, 112
 - General Requirements for Construction, 124
 - Geotechnical Investigation, 124
 - Horizontal Weirs, 117
 - In-Stream Facilities, 109
 - Location, 112
 - Maintenance, 113
 - Modified Puls Routing, 115
 - Multi-Purpose Uses, 112
 - Off-Line Facilities, 109
 - On-Line Facilities, 109
 - Orifices, 120
 - Outflow Pipes or Culverts, 117
 - Outlet Structure Design, 116
 - Pipe Spillways with Risers, 123
 - Pump Discharge, 124
 - Required Documentation of Design, 113
 - Safety Considerations, 113
 - Soils Report, 114
 - Storm Sewer Hydraulic Gradients, 112
 - Tailwater Depth, 116
- V-Notch Weirs, 119
- Detention Design, 109
- Detention Storage, 111
- Development Regulations
 - Flood Plain Areas, 133
- Discharge Calculations
 - Required for Open-Channel Design, 42
- Districts
 - Special Purpose, 1
- Disturbances in Channels
 - Direction of Propagation, 38
- Ditch Interceptor Structures
 - Grass-Lined Channels, 45
- DLTKR
 - Recommended Value, 28
- Documentation
 - Open-Channel Design, 42
- Dodson & Associates, Inc., 2
- Downstream Effects
 - Of Channel Improvements, 42
- Downstream Impact Analysis
 - Flood Plain Areas, 134
- Drainage Area
 - Rational Method, 10
- Drainage Area Curves
 - Storm Sewers, 75
- Drainage Area Map
 - Storm Sewers, 73
- Drainage Area vs. Discharge Curves
 - Interpolation, 16
- Drop Structure
 - See Straight Drop Spillway*
- Drop Structures
 - Open-Channel Design, 43
- Earthen Channels
 - Flow Velocities, 43
- Effective Impervious Ratio
 - Equation, 30
- Effects of Bridges, 65
- Elevation
 - Bridges, 65
- Embankment Material
 - Levee Systems, 128
- Encroachments
 - Flood Plain Areas, 133
- Endwalls and Headwalls
 - Culverts, 53
- Entrance Loss Coefficients
 - Storm Sewers, 76
- Entrance Losses
 - Culverts, 56
 - Storm Sewers, 75
- Entrance Losses Coefficients
 - Concrete Box Culverts, 57
 - Concrete Pipe Culverts, 57
 - Corrugated Metal Pipe Culverts, 57
- ERAIN
 - Recommended Value, 28
- Erosion Control
 - Backslope Drainage Systems, 103
 - Baffled Chutes, 97

- Bridges, 65
- Channel Bends, 86
- Channel Confluences, 85
- Concrete Slope Paving, 88
- Culverts, 54, 88
- Detention Basins, 113
- Grass-Lined Channels, 45
- Grass Establishment, 85
- Levee Systems, 129
- Open Channels, 85
- Pipe Outfalls, 105
- Rip-rap, 88
- Roadside Ditch Interceptor Structures, 105
- Roadside Ditches, 81
- SAF-Type Stilling Basin, 99
- Sediment Control During Construction, 107
- Seeding, 85
- Sloped Drop Structures, 96
- Soil Conditions, 85
- Storm Sewers, 74
- Straight Drop Spillways, 88
- Erosion Protection, 65
- Escape Stairways
 - Rectangular Concrete Pilot Channels, 46
- Espey, Huston & Associates, Inc., 3
- Example Application
 - HEC-1 Computer Program, 32
- Excess Rainfall
 - HEC-1 Computer Program, 27
- Exit Loss
 - Culverts, 57
- Expansions and Contractions
 - Open-Channel Design, 44
 - Water Surface Profile Computations, 50
- Exponential Loss Rate Function
 - HEC-1 Computer Program, 27
- Extreme Event Design
 - Detention Basins, 124
- Extreme Events
 - Detention Basins, 112
- Federal Emergency Management Agency
 - See *FEMA*
- Fill Limitations
 - Flood Plain Areas, 133
- Fill Permit
 - Flood Plain Areas, 134
- Flared Culvert Headwalls
 - Suitable Conditions, 53
- Flood Plain
 - Definition, 133
 - Development Regulations, 133
 - Downstream Impact Analysis, 134
 - Fill or Encroachments, 133
 - HEC-2 Computer Program, 134
 - Minimum Slab Elevation, 133
- Flood Plain Mapping
 - Flood Plain Areas, 134
- Flood Routing
 - HEC-1 Computer Program, 31
- Flood Routing Studies, 135
- Floodway Computations
 - Flood Plain Areas, 134
- Flow-Line Slope
 - Open-Channel Design, 43
- Flow Calculations
 - Required for Open-Channel Design, 42
- Flow Velocities
 - Clay Soils, 43
 - Concrete Lined Channels, 43
 - Open-Channel Design, 43
 - Rip-rap Lined Channels, 43
 - Sandy Soils, 43
 - Storm Sewers, 73
 - Unlined Channels, 43
- Fort Bend Co. Drainage Criteria Manual, 2
- Foundation
 - Levee Systems, 128
- Freeboard
 - Levee Systems, 129
 - Roadside Ditches, 81
- Frequencies
 - Channel Design, 42
- Frequency, 3
- Frequency Factor Adjustment
 - Rational Method, 5
- Frequency of Occurrence
 - Rational Method, 6
- Friction Losses
 - Culverts, 56
 - Storm Sewers, 75
 - Water Surface Profile Computations, 49
- Friction Slope
 - Definition, 38
- Future Slope Paving
 - Rectangular Concrete Pilot Channels, 47
- General Design Criteria
 - Storm Sewers or Overland Flow, 68
- General Design Methods
 - Storm Sewers, 74
- General Design Requirements
 - Detention Basins, 124
- Geotechnical Analysis
 - Levee Systems, 128
- Geotechnical Investigation
 - Detention Basins, 124
- Geotechnical Report
 - Grass-Lined Channels, 45
 - Required for Open-Channel Design, 42
- Grass-Lined Channels
 - Manning Roughness Coefficient, 43
 - Minimum Requirements, 44
- Grass Establishment
 - Erosion Control, 85
- Gravity Outlet
 - Levee Systems, 130
- Group A Soils, 22
- Group B Soils, 22
- Group C Soils, 22
- Group D Soils, 22
- Guardrails
 - Culverts, 54
- Guardrails for Culvert Headwalls, 53

- Harris Co. Drainage Criteria Manual, 2
- Harris County Flood Control District, 54
- Headwalls and Endwalls
 - Culverts, 53
- Headwater Depth
 - Culverts, 56
- HEC-1 Computer Program, 3, 12, 25
 - Detention Basins, 115
 - Example Application, 32
- HEC-2 Computer Program, 48
 - Channel Bend Losses, 50
 - Computation of Storage Volumes, 31
 - Normal Bridge Method, 51
 - Special Bridge Method, 51
- Horizontal Weirs
 - Detention Basins, 117
- Hydraulic Calculations
 - Required for Open-Channel Design, 42
- Hydraulic Computations
 - Detention Basins, 114
 - Roadside Ditches, 81
- Hydraulic Conveyance
 - Flood Plain Areas, 134
- Hydraulic Radius
 - Definition, 38
- Hydro-35, 26
- Hydrograph Development
 - Small Watersheds, 20
 - Watersheds Between 50 and 640 Acres, 12
- Hydrologic Analysis Requirements, 3
- Hydrologic Condition
 - As Factor in SCS Cover Complex, 22
- Hydrologic Engineering Center (HEC), 3
- Hyetograph
 - HEC-1 Computer Program, 25
- IDF Curves
 - See Intensity-Duration-Frequency Curves
- Impervious Cover
 - HEC-1 Computer Program, 28
 - Table of Recommended Values, 28
- Impervious Ratio, 30
- Imperviousness
 - Rational Method, 5
- In-Stream Detention Facilities, 109
- Inlet Control
 - Culverts, 56
 - Example, 61, 62
- Inlet Lead Alignment
 - Storm Sewers, 74
- Inlet or Manhole Loss
 - Storm Sewers, 75
- Inlet Time
 - Rational Method, 8
- Intensity-Duration-Frequency Curves
 - Southern Montgomery County, 7
- Interceptor Structures
 - Overland Flow, 84
- Internal Drainage System
 - Levee Systems, 128
- Interpolation
 - Drainage Area vs. Discharge Curves, 16
- Invert Slope
 - Open-Channel Design, 43
- Joint Sealant
 - Culverts, 56
- Lagging, 31
- Land Plan and Street Layout
 - Overland Flow, 77
- Land Treatment or Practice
 - As Factor in SCS Cover Complex, 22
- Land Use
 - As Factor in SCS Cover Complex, 22
- Land Use Maps, 3
- Length
 - Bridges, 64
- Length of Culverts, 53
- Levee Improvement Districts, 1
- Levee Systems, 127
 - Alignment, 129
 - Coincident Frequency Analysis, 129
 - Compaction, 128
 - Design Storm Frequency, 128
 - Design Storm Frequency for Pump Stations, 129
 - Embankment Material, 128
 - Erosion Control, 129
 - FEMA Regulations, 127
 - Foundation, 128
 - Freeboard, 129
 - Geotechnical Report, 128
 - Gravity Outlet and Outfall Channel, 130
 - Internal Drainage, 128
 - Maintenance Responsibility, 127
 - Pump Station Design, 129
 - Right-of-Way, 129
 - Side Slopes, 129
 - Single Event Analysis, 130
 - Structures, 129
 - Top Width, 129
- Loading
 - Culverts, 54
- Location
 - Detention Basins, 112
- Loss Computations
 - HEC-1 Computer Program, 27
- Losses
 - HEC-1 Computer Program, 27
- Low Flow
 - Bridges, 65
- Maintenance
 - Detention Basins, 113
- Maintenance Shelves
 - Rectangular Concrete Pilot Channels, 47
- Malcom, H.R., 4, 20
- Malcom Hydrograph Method, 4, 12, 20
- Manhole or Inlet Loss
 - Storm Sewers, 75
- Manholes
 - Storm Sewers, 76
- Manning "n" Value

- See Manning Roughness Coefficient
- Manning Equation, 38
 - Culverts, 57
 - Storm Sewers, 75
- Manning Roughness Coefficient
 - Application to the Manning Equation, 38
 - Composite, 30
 - Computation of Values from Components, 41
 - Concrete-Lined Channels, 43
 - Corrugated Metal Pipe, 54
 - Culverts, 54
 - Definition, 38
 - Effect of Channel Irregularities, 41
 - Effect of Channel Material, 41
 - Effect of Channel Meandering, 41
 - Effect of Channel Obstructions, 41
 - Effect of Channel Vegetation, 41
 - Effect of Cross-Section Variations, 41
 - Example of Composite Computation, 32
 - Grass-Lined Channels, 43
 - Improved Channels, 43
 - Open-Channel Design, 43
 - Rip-rap Lined Channels, 43
 - Roadside Ditches, 81
 - Storm Sewers, 73
 - Table of Values for Flood Plains, 41
 - Table of Values for Lined Channels, 39
 - Table of Values for Natural Streams, 40
 - Table of Values for Unlined Channels, 40
- Maps
 - Land Use, 3
 - Zoning, 3
- Master Plans
 - Watersheds, 3
- Maximum Allowable Ponding Level
 - Overland Flow, 77
- Maximum Channel Side Slope
 - Open-Channel Design, 43
- Minimum Channel Backslope Drains
 - Concrete-Lined Channels, 46
- Minimum Channel Bottom Slope
 - Rectangular Concrete Pilot Channels, 46
- Minimum Channel Bottom Width
 - Concrete-Lined Channels, 46
 - Grass-Lined Channels, 45
 - Open-Channel Design, 43
 - Rectangular Concrete Pilot Channels, 46
- Minimum Channel Control Joints
 - Concrete-Lined Channels, 46
 - Rectangular Concrete Pilot Channels, 47
- Minimum Channel Erosion Control
 - Grass-Lined Channels, 45
- Minimum Channel Escape Stairways
 - Rectangular Concrete Pilot Channels, 46
- Minimum Channel Interceptor Structures
 - Grass-Lined Channels, 45
- Minimum Channel Maintenance Shelves
 - Rectangular Concrete Pilot Channels, 47
- Minimum Channel Reinforcement
 - Concrete-Lined Channels, 46
- Minimum Channel Right-of-Way
 - Concrete-Lined Channels, 46
 - Grass-Lined Channels, 45
- Minimum Channel Seal Slab
 - Concrete-Lined Channels, 46
 - Rectangular Concrete Pilot Channels, 47
- Minimum Channel Side Slope
 - Grass-Lined Channels, 44
- Minimum Channel Slope
 - Open-Channel Design, 43
- Minimum Channel Structural Calculations
 - Rectangular Concrete Pilot Channels, 48
- Minimum Channel Toe Walls
 - Concrete-Lined Channels, 46
- Minimum Channel Vertical Wall Height
 - Rectangular Concrete Pilot Channels, 46
- Minimum Channel Weep Holes
 - Concrete-Lined Channels, 46
 - Rectangular Concrete Pilot Channels, 47
- Minimum Concrete
 - Rectangular Concrete Pilot Channels, 46
- Minimum Concrete Requirements
 - Concrete-Lined Channels, 45
- Minimum Grade
 - Roadside Ditches, 81
- Minimum Low Chord Elevation
 - Bridges, 65
- Minimum Reinforcement
 - Rectangular Concrete Pilot Channels, 46
- Minimum Size
 - Storm Sewers, 73
- Minimum Sizes
 - Culverts, 54
- Minimum Slab Elevation
 - Flood Plain Areas, 133
- Minor Losses
 - Storm Sewers, 75
- Mitigation
 - Flood Plain Areas, 134
- Modified Puls Routing Computations
 - Detention Basins, 115
- Modified Puls Routing Method, 31
- Modified Storage Adjustment Factor
 - Example Computation, 34
- Montgomery County Drainage Administrator
 - Administering Flood Plain Regulations, 133
 - Alternatives Values of Manning Roughness, 43
 - Analysis of Downstream Impacts, 116
 - Approval of Detention Outlet Structures, 116
 - Approval of Detention Pump Stations, 124
 - Approval of Dual-Use Detention Basins, 112
 - Approval of Rainfall Distributions, 135
 - Approval of Roadside Ditch Systems, 81
 - Approval of Seeding Methods, 85
 - Approval of Streamflow Routing Methods, 136
 - Approval of Subdivision Drainage Plan, 83
 - Approval of Variances, 1
 - Approval of Watershed Drainage Approach, 109

- Approval of Watershed Models, 136
- Bridge Design Storm Frequency, 64
- Channel Flow-Line Slope Variances, 43
- Comment on Project Location, 135
- Definition of Office, 1
- Design of Open Channels, 37
- Design Tailwater Depth for Detention, 116
- Downstream Impact Analysis, 135
- Emergency Overflow for Detention Basin, 124
- Establishing Existing Conditions HEC-1, 116
- Existing Flow Rates for Detention Design, 16
- Flood Plain Fill Permit, 134
- Geotechnical Report for Channel Design, 45
- Identifying Future Land Use Conditions, 135
- Inspection and Acceptance of Channels, 107
- Methods of Bridge Analysis, 65
- Necessity for Erosion Control Measures, 85
- Open Channel Design Information, 42
- Responsibilities, 1
- Review of Detention Basin Designs, 113
- Review of Hydraulic Models, 134
- Review of Storm Sewer Design, 68
- Soil Borings for Storm Sewer Design, 74
- Standard Step Backwater Computations, 48
- Supplying Flood Plain Information, 134
- Variances from Stated Criteria, 1
- Watersheds Smaller than 50 Acres, 4
- Montgomery County Engineer
 - Approval, 1, 37
- Multiple Uses
 - Detention Basins, 112
- N Value
 - Open-Channel Design, 43
- Non-Uniform Open-Channel Flow
 - Definition, 37
- Normal Depth
 - Definition, 38
- Off-Line Detention Facilities, 109
- Off-Site Drainage
 - Overland Flow, 83
- Offsetting Conveyance
 - Flood Plain Areas, 134
- On-Line Detention Facilities, 109
- Open-Channel Design
 - Channel Bends, 44
 - Channel Confluences, 44
 - Channel Erosion Control, 44
 - Channel Maintenance, 44
 - Channel Transitions, 44
 - Expansions and Contractions, 44
 - Geotechnical Report, 45
 - Grass-Lined Channels, 44
 - Min. Pilot Channel Vertical Wall Height, 46
 - Minimum Channel Backslope Drains, 45
 - Minimum Channel Bottom Width, 45
 - Minimum Channel Erosion Control, 45
 - Minimum Channel Interceptor Structures, 45
 - Minimum Channel Right-of-Way, 45
 - Minimum Channel Side Slopes, 44
 - Minimum Concrete for Channel Lining, 45
 - Minimum Lined Channel Backslope Drains, 46
 - Minimum Lined Channel Bottom Width, 46
 - Minimum Lined Channel Control Joints, 46
 - Minimum Lined Channel Reinforcement, 46
 - Minimum Lined Channel Right-of-Way, 46
 - Minimum Lined Channel Seal Slab, 46
 - Minimum Lined Channel Toe Walls, 46
 - Minimum Lined Channel Weep Holes, 46
 - Minimum Pilot Channel Bottom Slope, 46
 - Minimum Pilot Channel Bottom Width, 46
 - Minimum Pilot Channel Concrete, 46
 - Minimum Pilot Channel Control Joints, 47
 - Minimum Pilot Channel Escape Stairways, 46
 - Minimum Pilot Channel Future Paving, 47
 - Minimum Pilot Channel Maint. Shelves, 47
 - Minimum Pilot Channel Reinforcement, 46
 - Minimum Pilot Channel Seal Slab, 47
 - Minimum Pilot Channel Structural Calcs., 48
 - Minimum Pilot Channel Weep Holes, 47
 - Minimum Requirements, 44
 - Required Documentation, 42
 - Water Surface Profile Computations, 48
- Open-Channel Flow
 - Categories, 37
- Open-Channel Routing
 - HEC-1 Computer Program, 31
- Open Channel Design
 - Channel Bottom Width, 43
 - Channel Flow-Line Slope, 43
 - Channel Flow Velocities, 43
 - Channel Side Slope, 43
 - Manning Roughness Coefficient, 43
 - Right-of-Way Requirements, 48
- Orifices
 - Detention Basins, 120
- Outfalls
 - Storm Sewers, 77
- Outflow Pipes or Culverts
 - Detention Basins, 117
- Outlet Control
 - Culverts, 56
 - Example, 61, 62
- Outlet Structure
 - Detention Basins, 125
- Outlet Structure Design
 - Detention Basins, 116
- Overland Flow, 67
 - Channel Erosion Control, 44
 - Interceptor Structures, 84
 - Off-Site Drainage, 83
 - Storm Sewers, 73, 75
 - Temporary Drainage Swales, 84
- Overland Flow Design, 77

- Cul-de-sac Streets, 78
- Curved Streets, 79
- Land Planning and Street Layout, 77
- Maximum Allowable Ponding Levels, 77
- Street Intersections, 80
- Surface Swales, 81
- Parallel Culvert Headwalls
 - Suitable Conditions, 53
- Percent Impervious
 - Example Computation, 33
- Percent Urban Development, 30
- Piers and Abutments
 - Bridges, 65
- Pipe Culverts
 - Structural Requirements, 54
- Pipe Outfalls
 - Erosion Control, 105
- Pipe Spillway with Riser
 - Detention Basins, 123
- Platting Requirements
 - Channel Right-of-Way, 48
- Plotted Channel Cross-Sections
 - Required for Open-Channel Design, 42
- Plotted Stream Profile
 - Required for Open-Channel Design, 42
- Pond Bottom
 - Detention Basins, 125
- Ponding Adjustment Factor
 - Table of Coefficients, 31
- Ponding Area
 - Definition, 30
- Ponding Storage Adjustment Factor
 - Example Computation, 34
- Precast Inlets
 - Storm Sewers, 76
- Precast Reinforced Concrete Pipe, 54
- Precipitation
 - HEC-1 Computer Program, 25
- Precipitation Hyetograph
 - HEC-1 Computer Program, 25
- Precipitation Loss Computations
 - HEC-1 Computer Program, 27
- Profile
 - Culverts, 55
- Profile of Stream
 - Required for Open-Channel Design, 42
- Pump Station Design
 - Levee Systems, 129
- Pumped Discharge
 - Detention Basins, 124
- Rainfall Depths
 - Southern Montgomery County, 10
- Rainfall Excess
 - HEC-1 Computer Program, 27
- Rainfall Intensity
 - Rational Method, 4, 6
- Rainfall Loss Computations
 - HEC-1 Computer Program, 27
- Rainfall Records, 3
- Rational Method, 4
 - Assumptions, 4
 - Rational Method Curves
 - Storm Sewer or Overland Flow, 68
 - Storm Sewers, 74
 - Rational Method Drainage Area, 10
 - Rational Method Frequency Adjustment, 5
 - Rational Method Rainfall Intensity, 6
 - Rainfall Intensity, 4
 - Rational Method Runoff Coefficient, 4, 5
 - Rational Method Runoff Coefficients
 - Example Values, 6
 - Recreational Uses
 - Detention Basins, 112
 - Rectangular Concrete Pilot Channels
 - Minimum Requirements, 46
 - Recurrence Interval, 3
 - Reinforcement
 - Concrete-Lined Channels, 46
 - Rectangular Concrete Pilot Channels, 46
 - Required Documentation
 - Open-Channel Design, 42
 - Reservoir Routing
 - HEC-1 Computer Program, 31
 - Retention Storage, 111
 - Right-of-Way
 - Bridges, 65
 - Channel Maintenance, 44
 - Concrete-Lined Channels, 46
 - Detention Basins, 114
 - Grass-Lined Channels, 45
 - Levee Systems, 129
 - Storm Sewers, 74
 - Ultimate, 1
 - Right-of-Way Map
 - Required for Open-Channel Design, 42
 - Right-of-Way Requirements
 - Open-Channel Design, 48
 - Rip-rap
 - Bedding, 88
 - Block Description, 88
 - Erosion Control, 88
 - Mat Thickness, 88
 - Side Slopes, 88
 - Rip-rap Lined Channels
 - Flow Velocities, 43
 - Manning Roughness Coefficient, 43
 - Riser Pipes
 - Detention Basins, 123
 - Roadside Ditch Drainage
 - Overland Flow, 81
 - Roadside Ditch Interceptor Structures
 - Erosion Control, 105
 - Roadside Ditches
 - Bottom Width, 81
 - Depth, 81
 - Design Flows, 81
 - Erosion Control, 81
 - Freeboard, 81
 - Hydraulic Computations, 81
 - Manning Roughness Coefficient, 81
 - Minimum Grade, 81
 - Side Slopes, 81

- Roughness Coefficient
 - Open-Channel Design, 43
- Routing
 - HEC-1 Computer Program, 31
- RTIMP
 - Example Computation, 33
 - Recommended Value, 28
- RTIOL
 - Recommended Value, 28
- Runoff Coefficient
 - Rational Method, 4, 5
- Runoff Coefficients
 - Composite, 5
 - Example Values, 6
- Runoff Potential
 - According to SCS Soil Classifications, 22
- Runoff Volume
 - Graph for Determining from SCS Curve No., 22
 - Small Watersheds, 21
- SAF-Type Stilling Basin
 - Design Procedure, 99
- Safety Considerations
 - Detention Basins, 113
- Sandy Soils
 - Flow Velocities, 43
- SCS Cover Complex, 22
- SCS Curve Number, 21
 - Table of Values for Rural Areas, 23
 - Tables of Values for Urban Areas, 24
- SCS Dimensionless Unitgraph, 20
- SCS Soil Classification System, 21
- SCS Soil Groups
 - Determination, 22
- SCS TR-55
 - Computing Travel Time, 8
- Seal Slab
 - Concrete-Lined Channels, 46
 - Rectangular Concrete Pilot Channels, 47
- Secondary Drainage, 67
- Sediment Control During Construction, 107
- Seeding
 - Erosion Control, 85
- Sheet Flow, 67
 - Channel Erosion Control, 44
- Side Slope
 - Grass-Lined Channels, 44
- Side Slopes
 - Levee Systems, 129
 - Open-Channel Design, 43
 - Roadside Ditches, 81
- Single Event Analysis
 - Levee Systems, 130
- Site Map
 - Required for Open-Channel Design, 42
- Slope
 - Open-Channel Design, 43
- Slope Stability
 - Open-Channel Design, 43
- Sloped Drop Structures
 - Erosion Control, 96
- Soil Borings
 - Storm Sewers, 74
- Soil Conditions
 - Erosion Control, 85
- Soil Conservation Service
 - WSP-2 Computer Program, 48
- Soil Groups, 21
- Soils
 - Channel Erosion Control, 44
- Soils Report
 - Detention Basins, 114
 - Grass-Lined Channels, 45
 - Required for Open-Channel Design, 42
- Specific Energy
 - At Critical Depth, 37
- Stahl, Al, 2
- Starting Water Surface Elevation
 - Storm Sewers, 73
 - Water Surface Profile Computations, 49
- Steady Open-Channel Flow
 - Definition, 37
- Steep Channel Sections
 - Channel Erosion Control, 44
- Storage Coefficient
 - Clark Unit Hydrograph Method, 28
- Storage Coefficient, Clark
 - Example Computation, 34
- Storage Considerations
 - Flood Plain Areas, 134
- Storm Distribution
 - HEC-1 Computer Program, 25
- Storm Frequencies
 - Channel Design, 42
- Storm Frequency, 3
- Storm Recurrence Interval, 3
- Storm Sewers
 - Alignment, 74
 - City of Houston Rational Method, 68
 - Consideration in Channel Design, 42
 - Construction Specifications, 73
 - Design Criteria, 73
 - Detention Basins, 112
 - Drainage Area Curves, 75
 - Drainage Area Map, 73
 - Entrance Loss Coefficients, 76
 - Entrance Losses, 75
 - Flow Calculations, 73
 - Flow Velocities, 73
 - Friction Losses, 75
 - General Design Criteria, 68
 - Hydraulic Calculations, 73
 - Inlet Capacity, 75
 - Inlet Lead Alignment, 74
 - Inlets, 76
 - Manholes, 76
 - Manholes or Inlet Losses, 75
 - Manning Roughness Coefficient, 73
 - Minimum Diameter, 73
 - Minor Losses, 75
 - Outfall Erosion Control, 74
 - Outfalls, 77
 - Overland Flow, 73

- Peak Flow Rates, 74
- Rational Method, 68
- Rational Method Curves, 74
- Required Drawings, 73
- Right-of-Way, 74
- Soil Borings, 74
- Starting Elevation, 73, 74
- Starting Water Surface Elevation, 75
- Typical 24- to 42-inch Outfall Structure, 71
- Typical 42-inch and Larger Outfall, 72
- Straight Drop Spillway
 - Design Flow Rate, 92
 - Design Procedures, 92
 - Erosion Control, 88
 - Example of Design Procedure, 93
 - Hydraulics, 90
 - Slope Protection Requirements, 93
- Stream Profile
 - Required for Open-Channel Design, 42
- Stream Profiles
 - Flood Plain Areas, 134
- Streamflow Routing
 - HEC-1 Computer Program, 31
- Street Intersections
 - Overland Flow, 80
- STRKR
 - Recommended Value, 28
- Structural Calculations
 - Rectangular Concrete Pilot Channels, 48
- Structural Requirements
 - Culverts, 54
- Structures
 - Levee Systems, 129
- Sub-Critical Flow, 38
- Super-Critical Flow, 38
- Surface Swales
 - Overland Flow, 81
- Survey Benchmark Information
 - Required for Open-Channel Design, 42
- Tailwater Depth
 - Culverts, 56
 - Detention Basins, 116
- Temporary Drainage Swales
 - Overland Flow, 84
- Texas Water Development Board, 2
- Time-Area Curve
 - Clark Unit Hydrograph, 28
- Time of Concentration
 - Clark Unit Hydrograph Method, 28
 - Rational Method, 4, 6
- Time of Concentration, Clark
 - Example Computation, 33
- Time of Flow in the Conduit
 - Rational Method, 9
- Time of Storage
 - Rational Method, 9
- Toe Walls
 - Concrete-Lined Channels, 46
- Top Width
 - Levee Systems, 129
- TP-40, 25
- Transition Losses
 - Water Surface Profile Computations, 50
- Transitions
 - Open-Channel Design, 44
- U.S. Army Corps of Engineers, 3
 - HEC-2 Computer Program, 48
- Uniform Open-Channel Flow
 - Definition, 37
- Unit Hydrograph
 - HEC-1 Computer Program, 28
- Unlined Channels
 - Flow Velocities, 43
- Unstead Open-Channel Flow
 - Definition, 37
- Urbanization
 - Hydrologic Effects, 3
- V-Notch Weirs
 - Detention Basins, 119
- Variances, 1
- Vertical Wall Height
 - Rectangular Concrete Pilot Channels, 46
- Vicinity Map
 - Required for Open-Channel Design, 42
- Vogt Engineers, Inc., 2
- Volume of Runoff
 - Graph for Determining from SCS Curve No., 22
 - Small Watersheds, 21
- Warped Culvert Headwalls
 - Suitable Conditions, 54
- Water Surface Elevations
 - Bridges, 65
- Water Surface Profile Computations
 - Bridges and Culverts, 51
 - Channel Bends, 50
 - Channel Cross-Section Data Points, 49
 - Channel Cross-Section Orientation, 48
 - Channel Cross-Section Spacing, 49
 - Channel Friction Losses, 49
 - Channel Stationing, 49
 - Channel Transitions, 50
 - Direct Step Computations, 48
 - Expansions and Contractions, 50
 - HEC-2 Computer Program, 48
 - Manning Equation, 49
 - Normal Depth, 48
 - Open-Channel Design, 48
 - Standard Step Computations, 48
 - Starting Water Surface Elevation, 49
 - WSP-2 Computer Program, 48
- Watershed Length, 30
- Watershed Map
 - Detention Basins, 114
 - Required for Open-Channel Design, 42
- Watershed Master Plans, 3
- Watershed Slope, 30
- Watershed Storage Coefficient
 - Clark Unit Hydrograph Method, 28
- Watershed Storage Coefficient, Clark

Example Computation, 34	Detention Basins, 118
Wear, Robert R., 2	Weirs
Weep Holes	Detention Basins, 117
Concrete-Lined Channels, 46	WSP-2 Computer Program, 48
Rectangular Concrete Pilot Channels, 47	
Weighted Manning Roughness Coefficient, 30	Zoning Maps, 3
Weir Submergence	

CHART 1

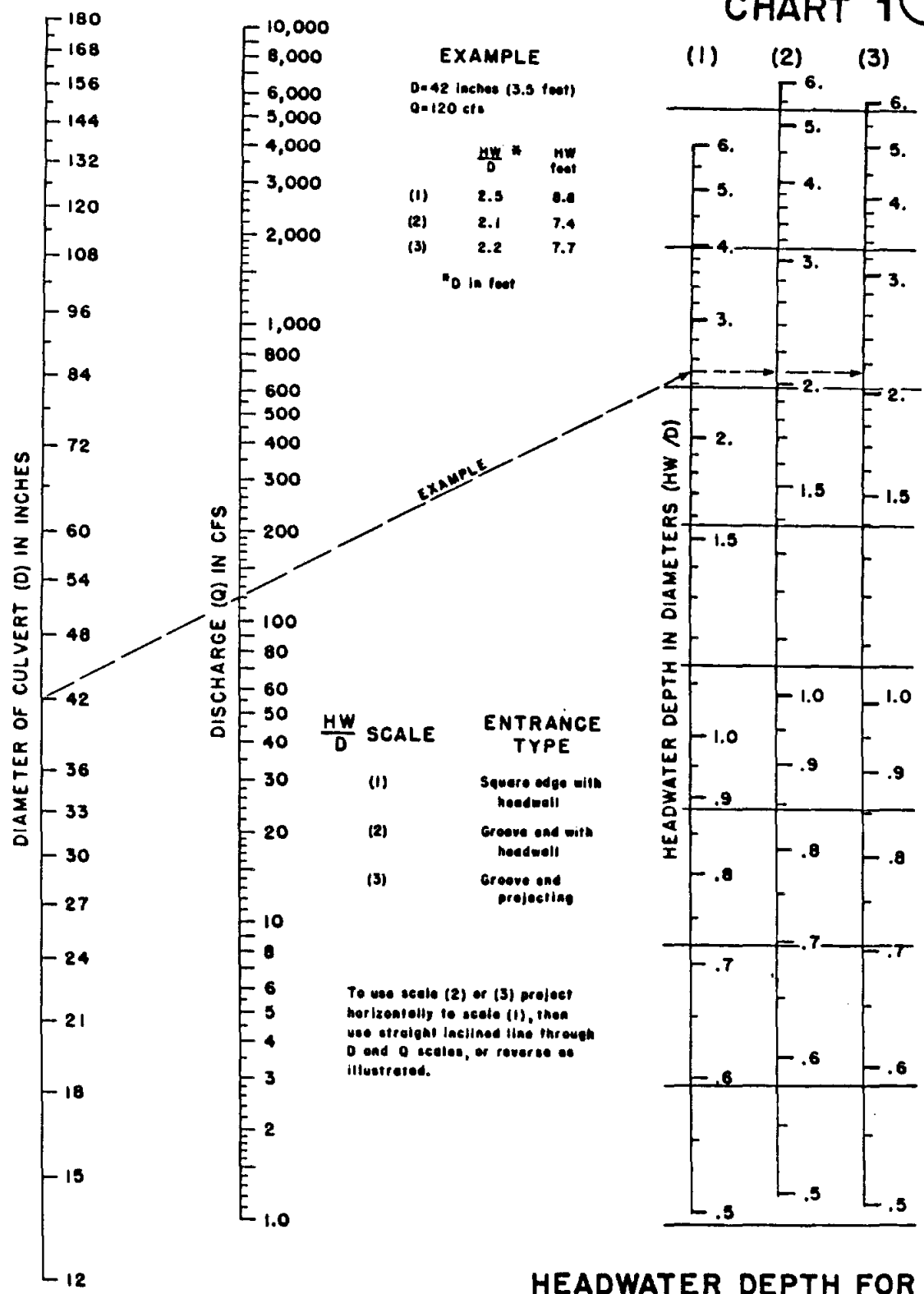

HEADWATER DEPTH FOR CONCRETE PIPE CULVERTS WITH INLET CONTROL

HEADWATER SCALES 283
 REVISED MAY 1964

BUREAU OF PUBLIC ROADS JAN. 1963

CHART 2

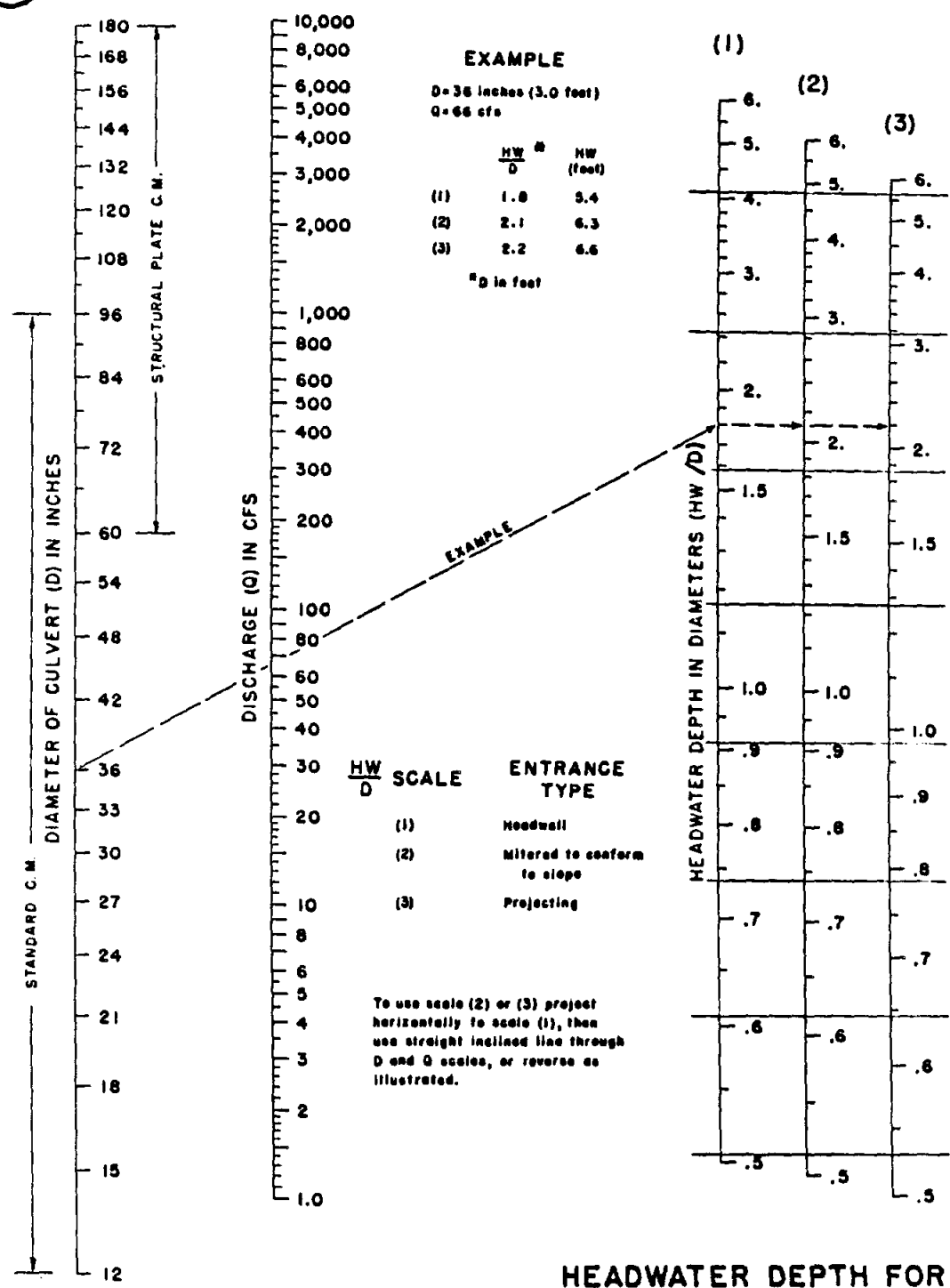

**HEADWATER DEPTH FOR
 C. M. PIPE CULVERTS
 WITH INLET CONTROL**

CHART 3

$\frac{1}{8}$	$\frac{3}{8}$	$\frac{1}{2}$	$\frac{3}{4}$	ENTRANCE TYPE
0.042	0.083	0.042	0.083	A
0.083	0.125	0.042	0.125	B

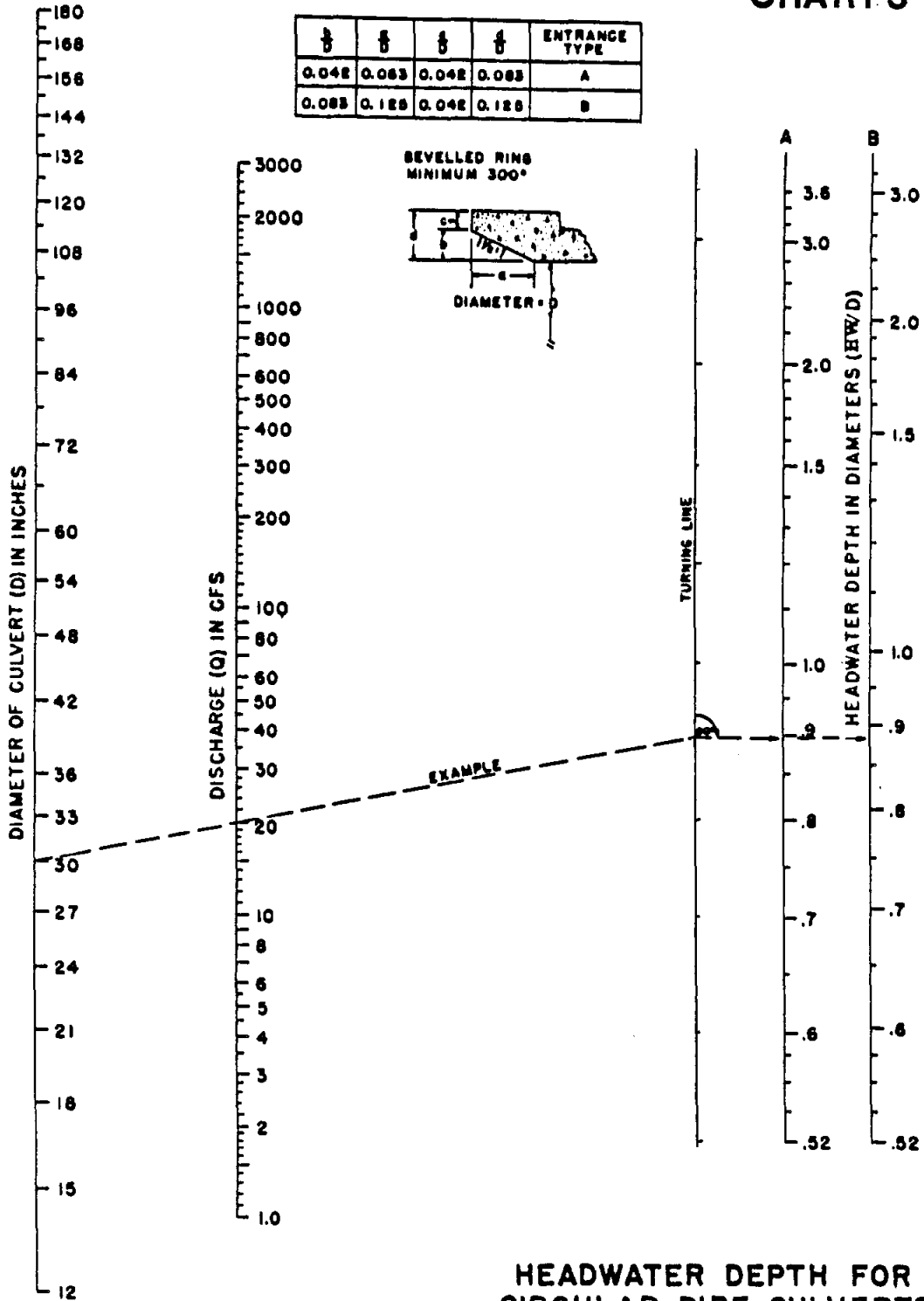

FEDERAL HIGHWAY ADMINISTRATION
MAY 1973

HEADWATER DEPTH FOR
CIRCULAR PIPE CULVERTS
WITH BEVELED RING
INLET CONTROL



CHART 4

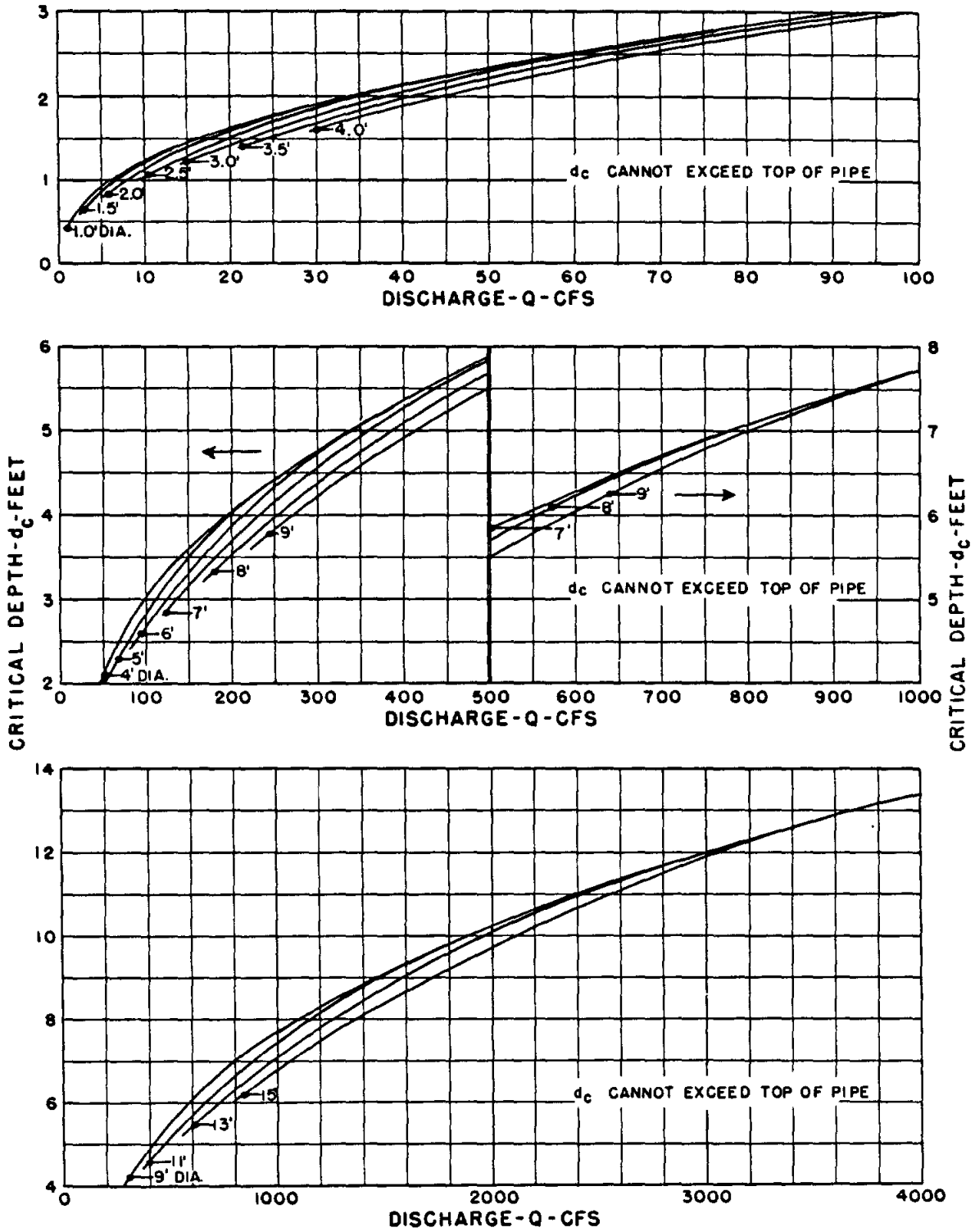

BUREAU OF PUBLIC ROADS
JAN. 1964

CRITICAL DEPTH CIRCULAR PIPE

CHART 5

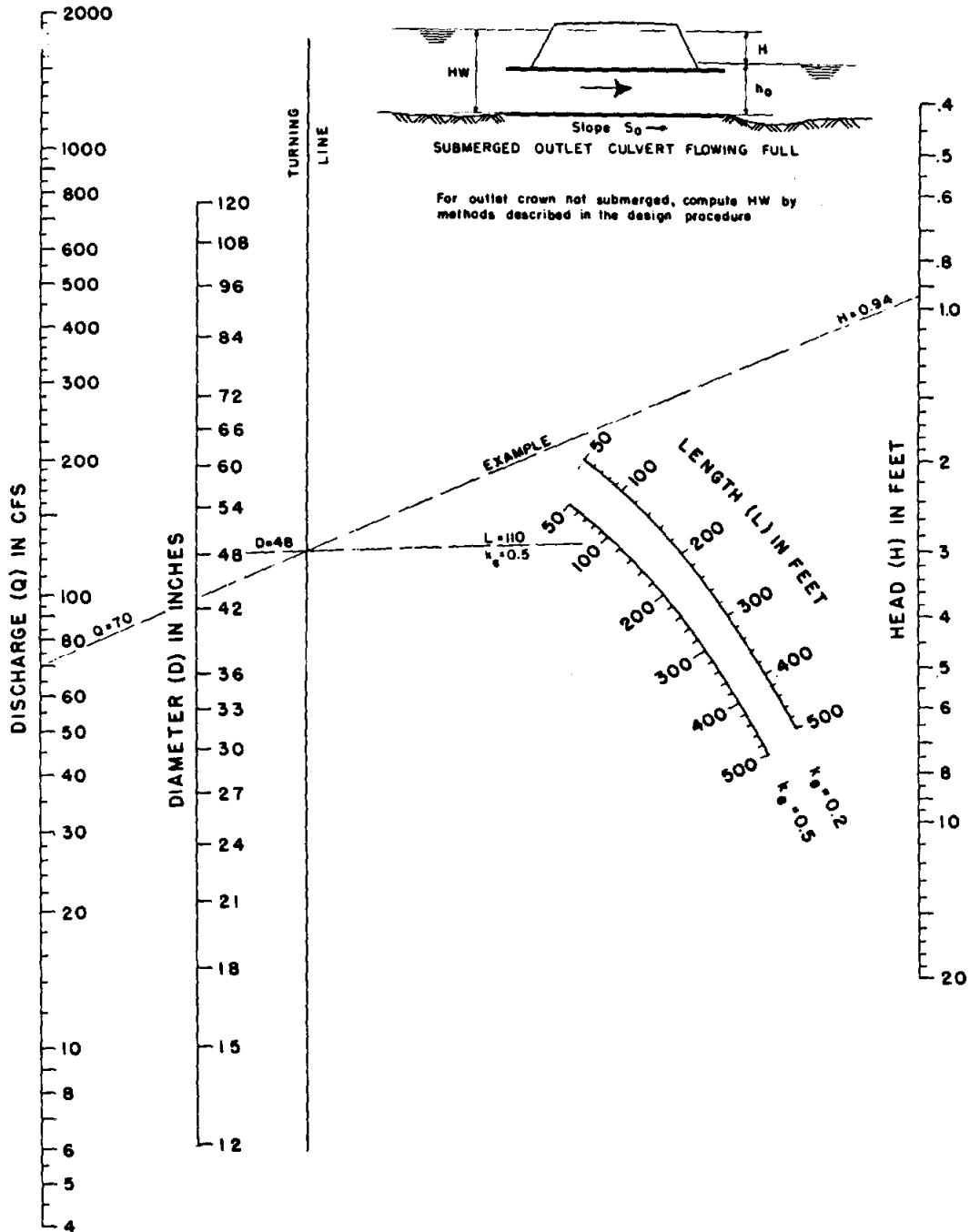
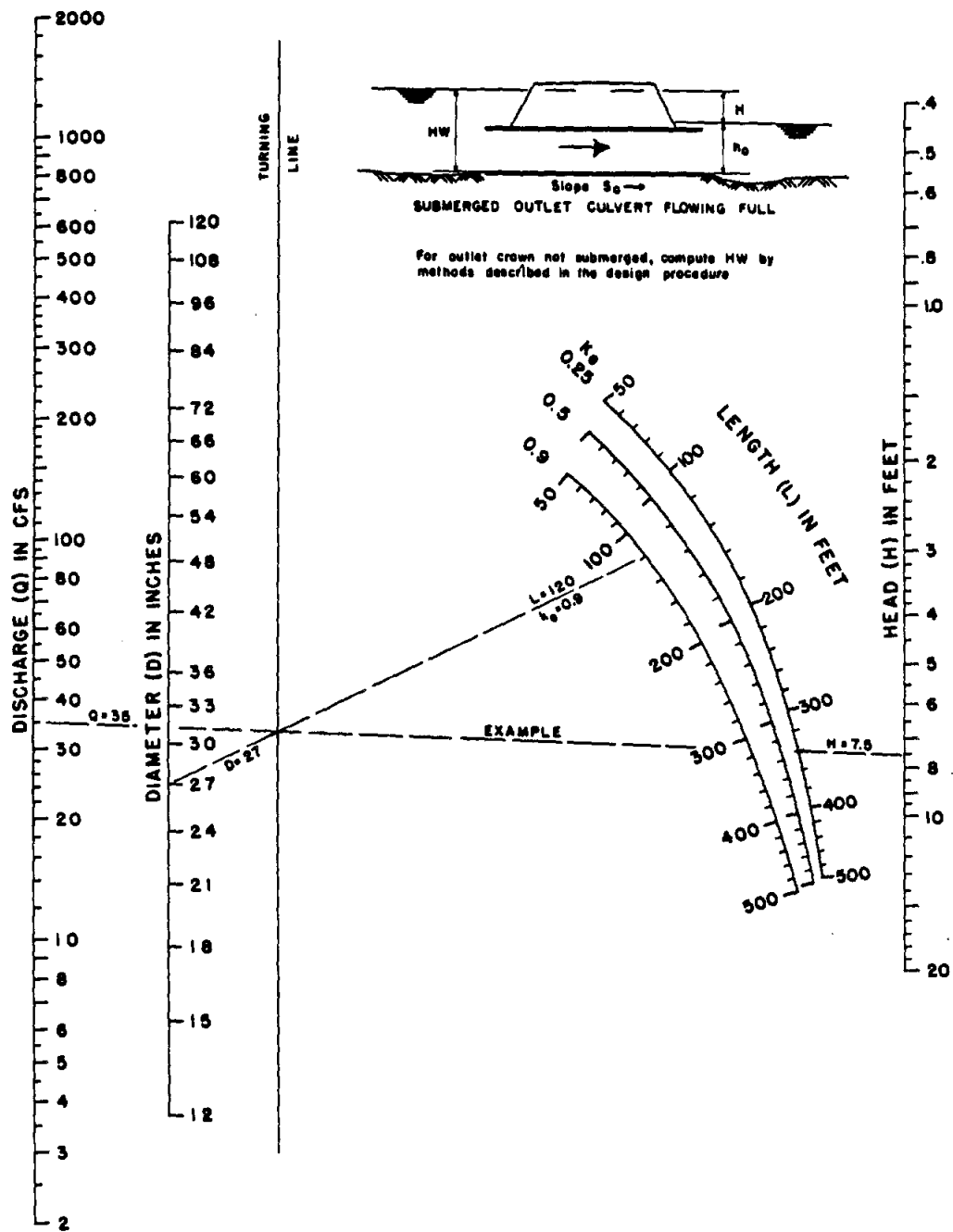

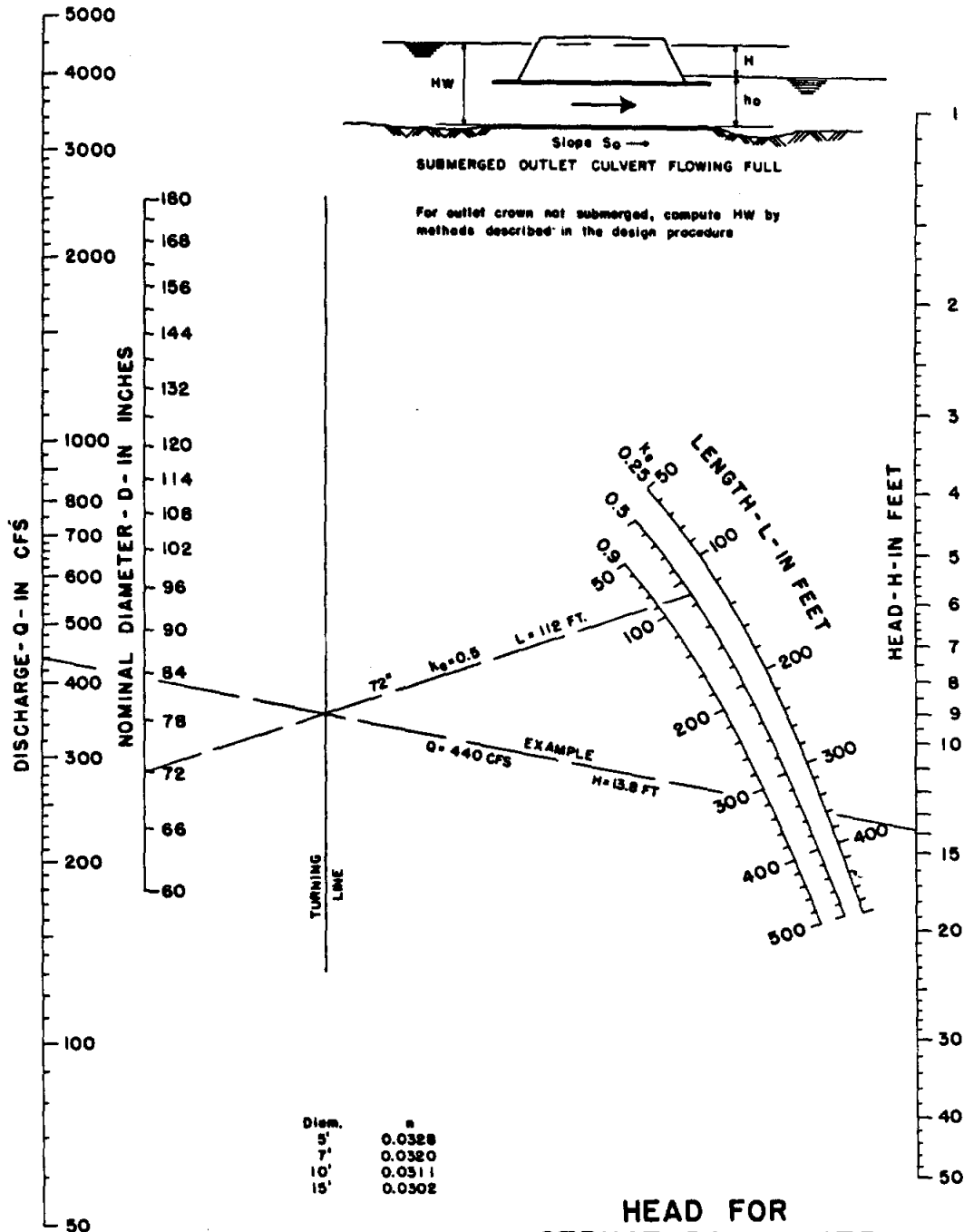

CHART 6



HEAD FOR
STANDARD
C. M. PIPE CULVERTS
FLOWING FULL
 $n = 0.024$

CHART 7



**HEAD FOR
 STRUCTURAL PLATE
 CORR. METAL PIPE CULVERTS
 FLOWING FULL
 n = 0.0328 TO 0.0302**



CHART 8

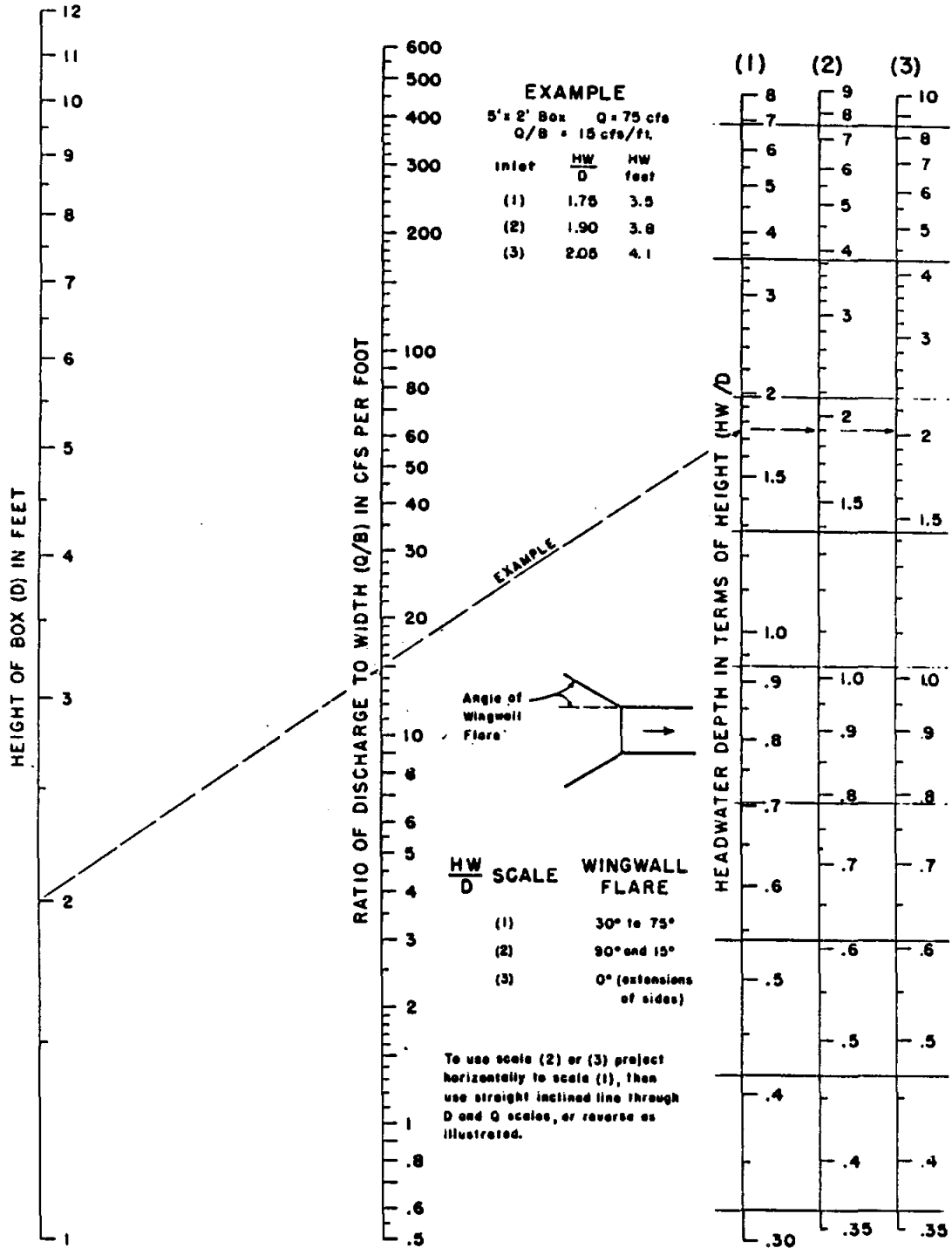
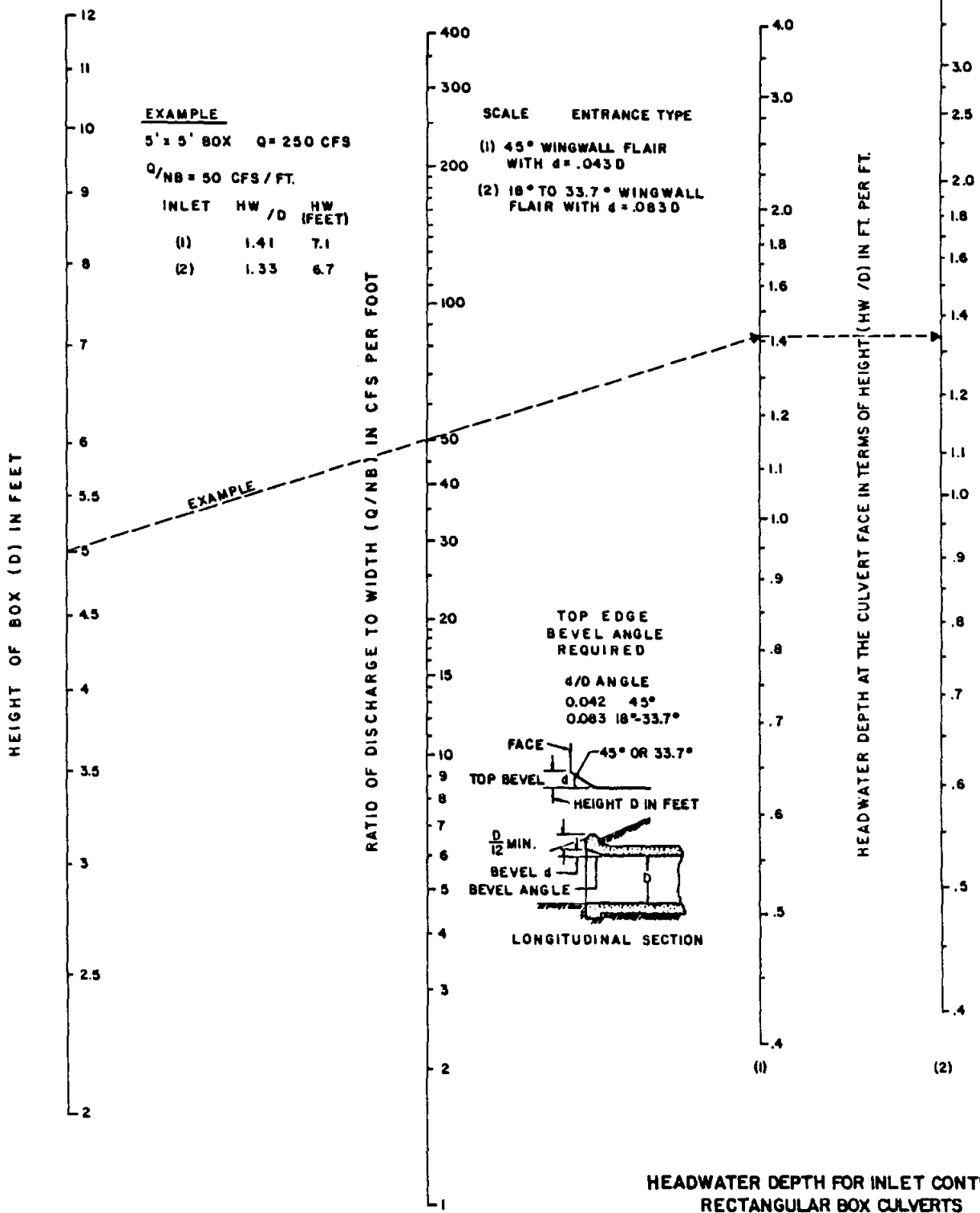



CHART 9



HEADWATER DEPTH FOR INLET CONTROL
 RECTANGULAR BOX CULVERTS
 FLARED WINGWALLS 18° TO 33.7° & 45°
 WITH BEVELED EDGE AT TOP OF INLET



CHART 10

EXAMPLE

B=7 FT. D=5 FT. Q=500 CFS Q/NB = 71.5

	HW	HW
ALL EDGES	D	feet
CHAMFER 3/4"	2.31	11.9
1/2 IN/FT BEVEL	2.08	10.4
1 IN/FT BEVEL	1.88	9.4

INLET FACE-ALL EDGES:

1 IN/FT BEVELS 33.7° (1:1.5)
 1/2 IN/FT BEVELS 45° (1:1)
 3/4 INCH CHAMFERS

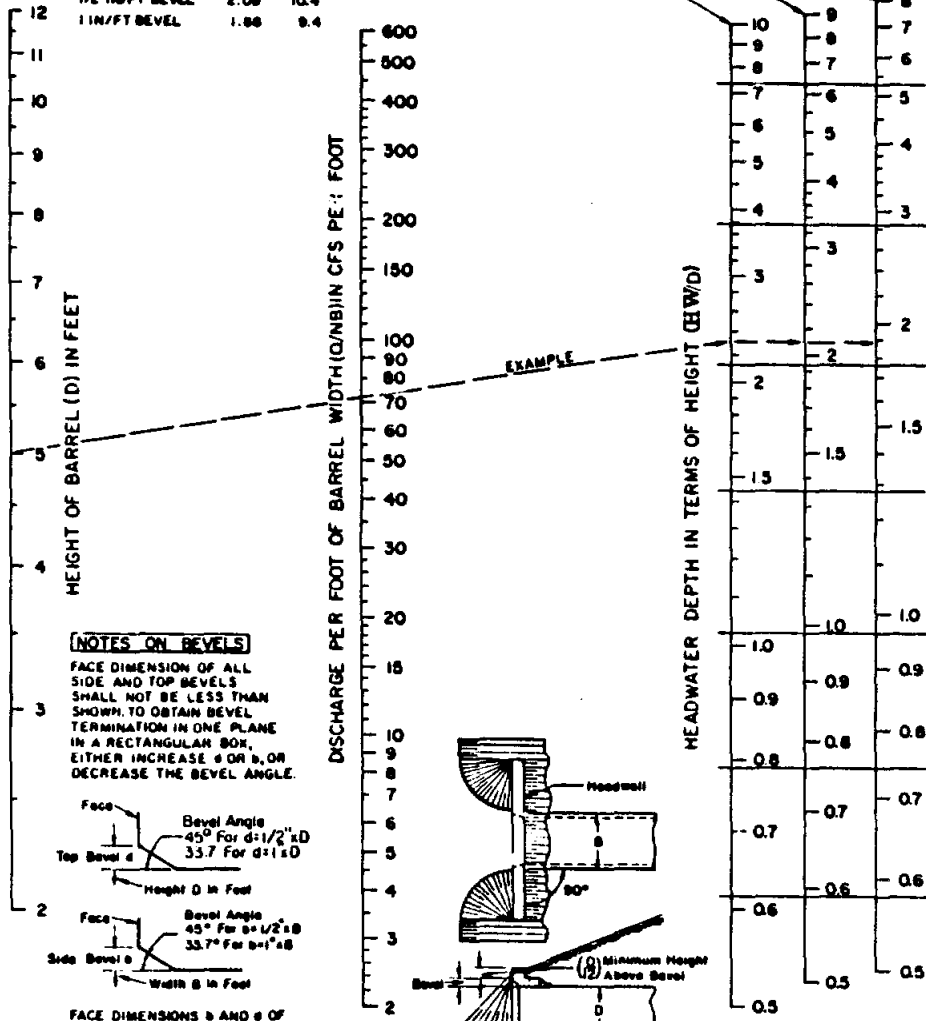

HEADWATER DEPTH FOR INLET CONTROL
 RECTANGULAR BOX CULVERTS
 90° HEADWALL
 CHAMFERED OR BEVELED INLET EDGES

FEDERAL HIGHWAY ADMINISTRATION
 MAY 1973

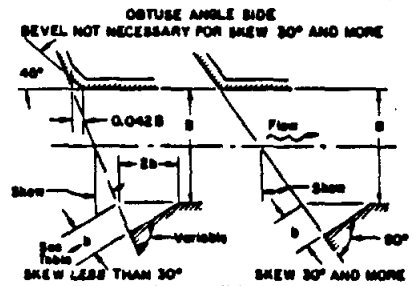
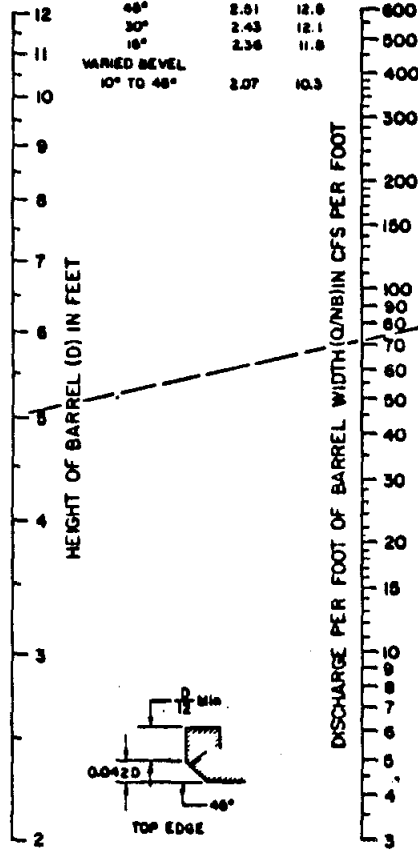

CHART 11

EXAMPLE

B=77 FT D=6 FT Q=600 CFS

EDGE & SKEW	HW D	HW 100'
45° 3/4" CHAMFER	2.01	12.6
30°	2.43	12.1
15°	2.36	11.8
VARIABLE BEVEL 10° TO 45°	2.07	10.3



BEVELED INLET EDGES
DESIGNED FOR SAME CAPACITY AT ANY SKEW

FEDERAL HIGHWAY ADMINISTRATION
MAY 1973

BEVELED EDGES - TOP AND SIDES
3/4 INCH CHAMFER ALL EDGES

SKEW ANGLE → 45° 30° 15° 10°-45°

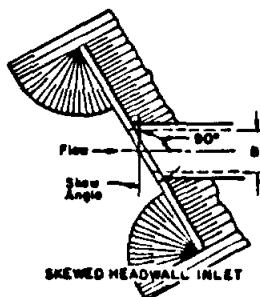
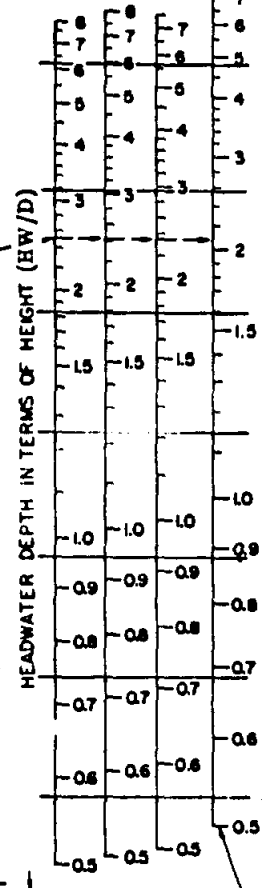

BEVELED EDGES AS DETAILED

SKEW ANGLE	SIDE BEVEL b
10°	3/4" b (1")
15°	1" b
22-1/2°	1-1/4" b
30°	1-1/2" b
37-1/2°	2" b
45°	2-1/2" b

HEADWATER DEPTH FOR INLET CONTROL SINGLE BARREL BOX CULVERTS SKEWED HEADWALLS CHAMFERED OR BEVELED INLET EDGES

CHART 12

EXAMPLE

B = 7 FT. D = 5 FT. Q = 500 CFS

$$\frac{Q}{B} = 71.5$$

INLET B/W	HW D	HW FT.
NORMAL	0	0
45° WW	2.18	10.9
18.4° WW	2.27	11.4
SKEWED 15°-40°		
18.4 OR MORE WW	2.20	11.0

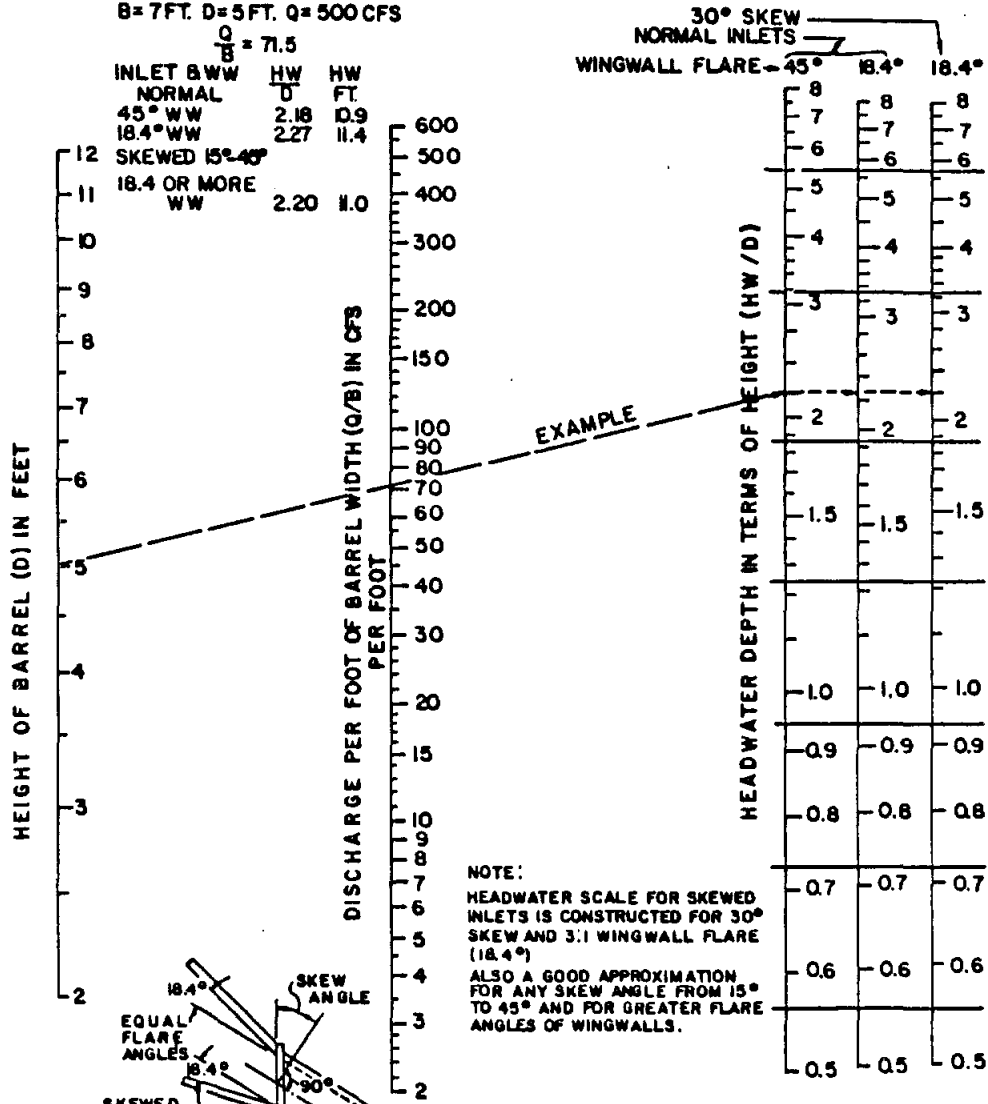

NOTE:
HEADWATER SCALE FOR SKEWED
INLETS IS CONSTRUCTED FOR 30°
SKEW AND 3:1 WINGWALL FLARE
(18.4°)
ALSO A GOOD APPROXIMATION
FOR ANY SKEW ANGLE FROM 15°
TO 45° AND FOR GREATER FLARE
ANGLES OF WINGWALLS.

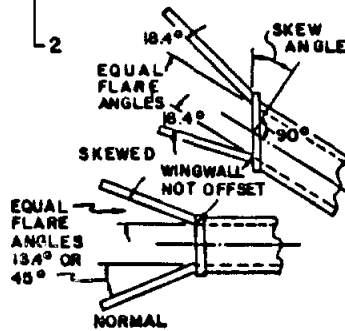

WINGWALL INLETS

BUREAU OF PUBLIC ROADS
OFFICE OF R & D AUGUST 1968

HEADWATER DEPTH FOR INLET CONTROL
RECTANGULAR BOX CULVERTS
FLARED WINGWALLS
NORMAL AND SKEWED INLETS
3/4" CHAMFER AT TOP OF OPENING

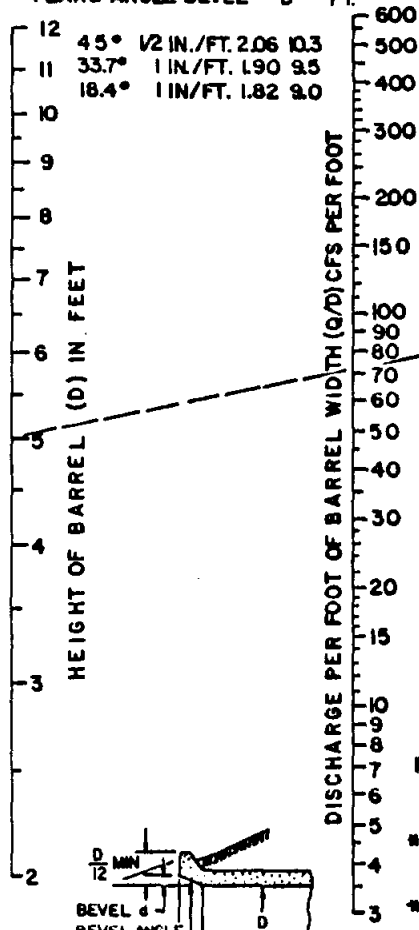

CHART 13

EXAMPLE

B = 7 FT. D = 5 FT. Q = 600 C.F.S.
 $\frac{Q}{B} = 71.5$

WINGWALL TOP EDGE FLARE ANGLE	BEVEL	HW / D	HW / FT.
45°	1/2 IN./FT.	2.06	10.3
33.7°	1 IN./FT.	1.90	9.5
18.4°	1 IN./FT.	1.82	9.0



18.4° WW B d = 0.083D
 33.7° WW B d = 0.083D
 45° WW B d = 0.042D

TOP EDGE BEVEL ANGLE REQUIRED

d	ANGLE
0.042	45°
0.083	33.7°

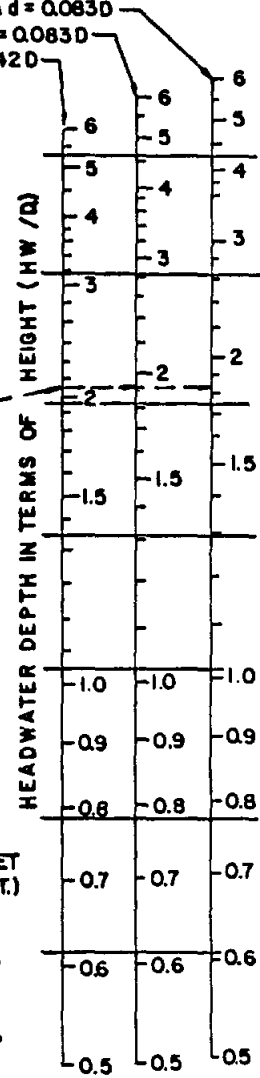

WINGWALLS

FLARE ANGLE	MIN. OFFSET
1:1	45° 3/4" x B (FT.)
1:1.5	33.7° 1" x B
* 1:2	26.6° 1-1/4" x B
1:3	18.4° 1-1/2" x B

* USE 33.7° x 0.0083D TOP EDGE BEVEL AND READ HW ON SCALE FOR 18.4° WW

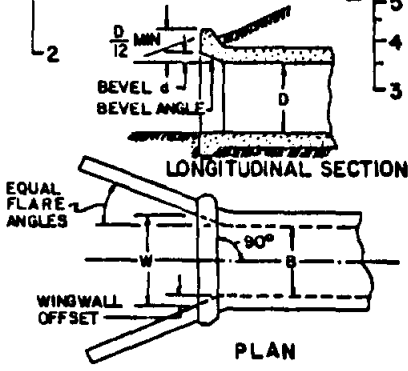

HEADWATER DEPTH FOR INLET CONTROL
 RECTANGULAR BOX CULVERTS
 OFFSET FLARED WINGWALLS
 AND BEVELED EDGE AT TOP OF INLET

BUREAU OF PUBLIC ROADS
 OFFICE OF R & D AUGUST 1968



CHART 14

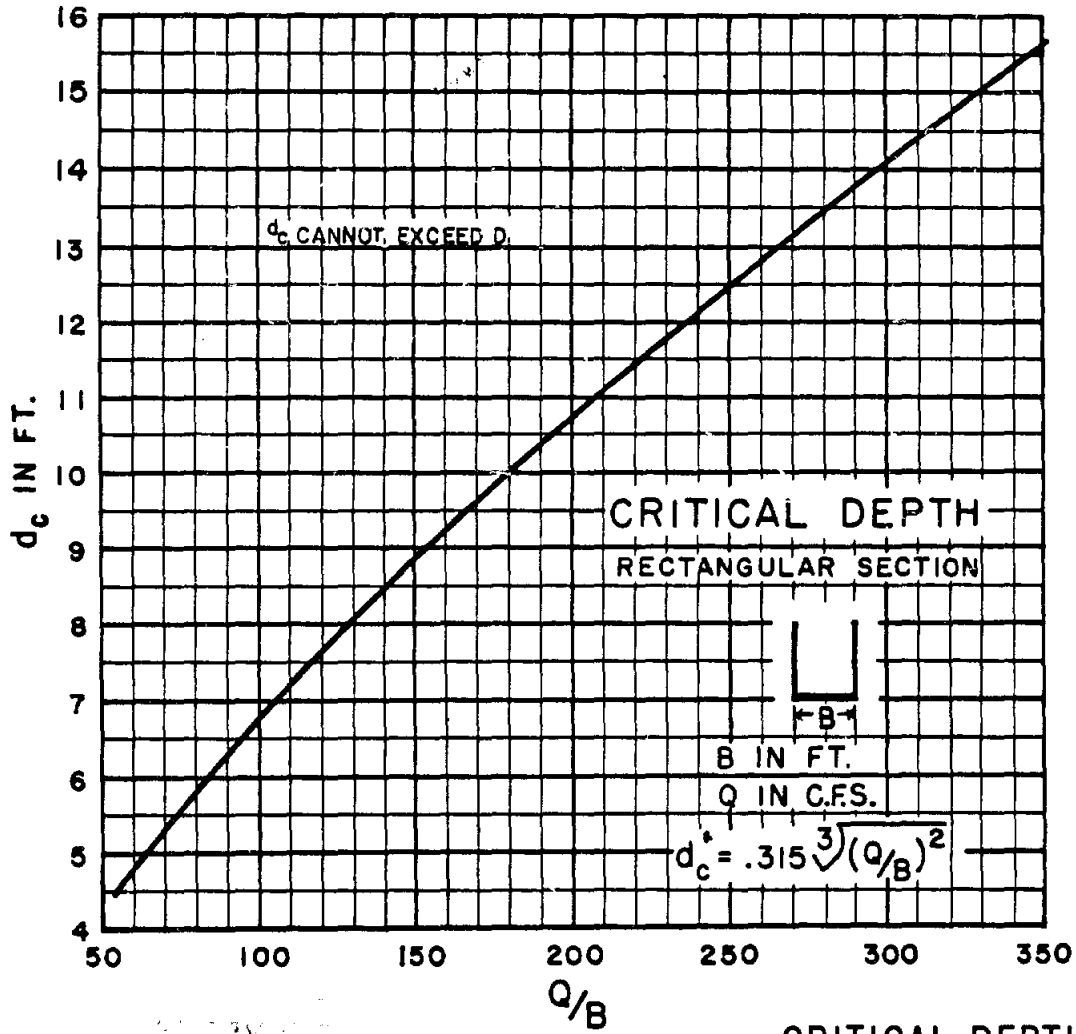
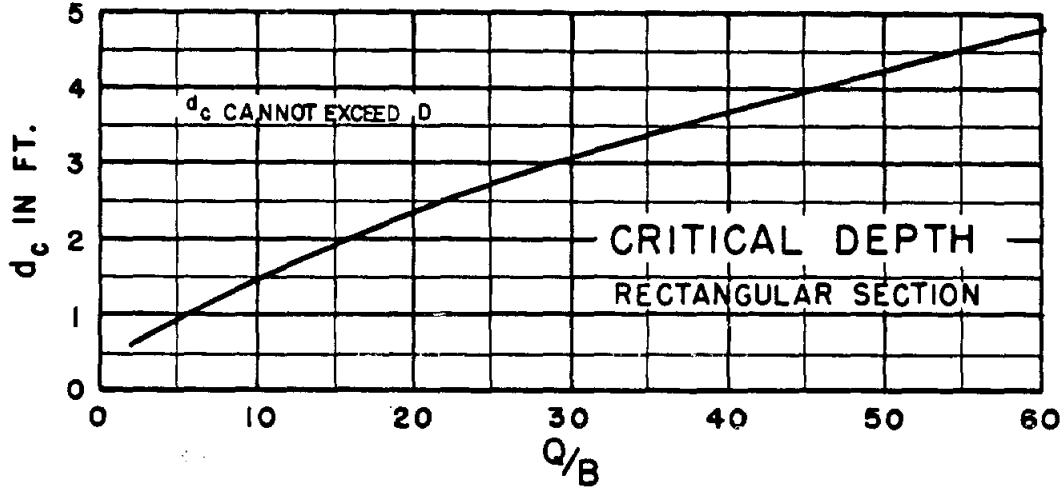

BUREAU OF PUBLIC ROADS JAN. 1963

5-38

CRITICAL DEPTH
RECTANGULAR SECTION

CHART 15

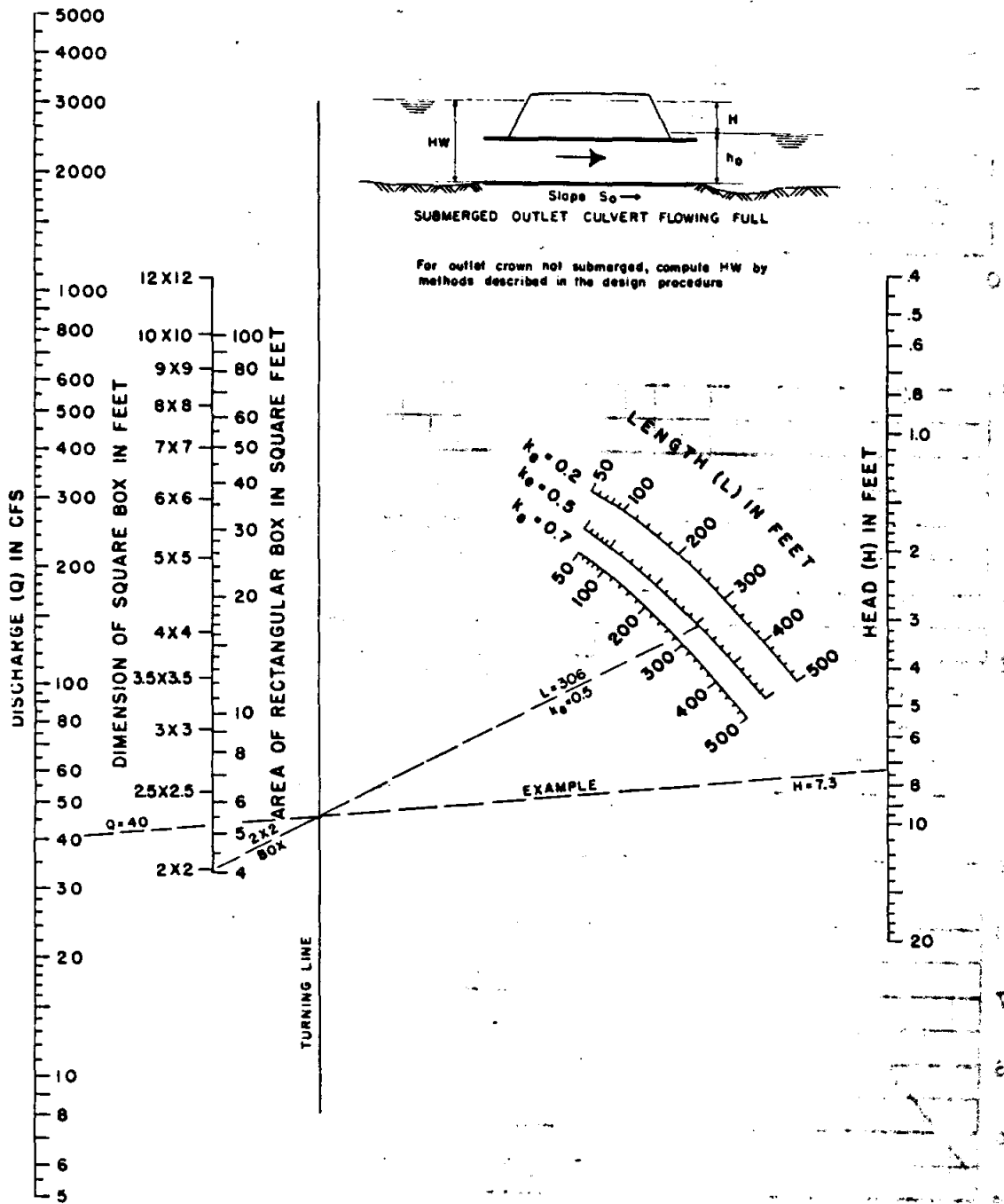

**HEAD FOR
 CONCRETE BOX CULVERTS
 FLOWING FULL**
 $n = 0.012$